

FORMAX[®]

6304 Series
Inserter

OPERATOR MANUAL
Rev. 1

TABLE OF CONTENTS

1	Health, Safety and Environment	2
	1.1 Precautions and Safety Issues	2
2	Functional description	5
	2.1 Overview	5
	2.2 Operating Controls	7
	2.3 Control Panel	8
	2.4 Software Description	8
3	Operating Instructions	12
	3.1 Installation	12
	3.2 Preparation ..	12
	3.3 Starting Up	13
	3.4 Loading Documents	14
	3.5 Loading Envelopes	16
	3.6 Filling the Sealing Liquid Reservoir	17
	3.7 Run a Job	17
	3.8 Using an Automatic Job	18
	3.9 Daily Mail	18
	3.10 Stopping the system	19
4	Job Programming	20
	4.1 Create a Job	20
	4.2 Job Settings	21
	4.3 Edit a Job	27
	4.4 Copy a Job	28
	4.5 Delete a Job	28
5	Options	29
	5.1 Activate an Option	29
	5.2 Reading ..	29
	5.3 Online Services	36
	5.4 Production Feeder (MF-2)	39
	5.5 High Capacity Feeder	41
	5.6 High Capacity Vertical Stacker (HCVS-1)	42
	5.7 Side exit	42
	5.8 Mail Piece Production Control (MPPC) (Option)	42
	5.9 Mailing/Franking	42
6	Operator Maintenance	43
7	Fault finding	44
	7.1 Error Messages	44
	7.2 Clearing Stoppages	45
	7.3 Operator Troubleshooting	46
8	Specifications	50
	8.1 Technical Specifications	50
	8.2 Configuration Dimensions	50
	8.3 Other Specifications	50
	8.4 Document Specifications	51
	8.5 Envelope and Insert Specifications	51
	8.6 Specifications High Capacity Vertical Stacker	52
	8.7 Specifications Production Feeder	53
9	Terminology	54
	Index	60

1. HEALTH, SAFETY AND ENVIRONMENT

1.1 Precautions and Safety Issues

Thoroughly read this operator manual, before using this system.

According to the EC declaration (European Commission) following the Low Voltage Directive (2006/95/EC), this operator manual must be available in the national language(s) of the country where the system is delivered. Therefore, if you do not have an operator manual in your country's language(s), contact your authorized distributor.

Warnings

- Disconnect the mains supply before performing any maintenance.
- Before connecting check if the system is suitable for the local mains voltage. Refer to the type plate.

Safety Precautions

- Only competent personnel should operate this system.
If incompetent personnel do operate this system, the manufacturer does not accept responsibility for any resulting accidents or injuries.
- Only skilled persons, who are aware of the risks involved, may open the protective covers.
For safety reasons, the system will not function when the covers are open.
- Keep long hair, fingers, jewelry, etc. away from rotating and moving parts.
- The power connection must be easily accessible, preferably close to the system.
- For safety reasons, it is essential that the system is connected to a socket outlet that has a protective earth connection.
- Over-current protection in the equipment also relies on the branch circuit protection (max. 20 A).
- The following part(s) is (are) considered the equipment disconnect device(s):
 - Power supply cord plug

Conventions



Note

A note gives additional relevant information.

Caution

Indicates the presence of a hazard that can cause personal injury or property damage, if the hazard is not avoided.

2. FUNCTIONAL DESCRIPTION

The system feeds, folds and inserts documents into envelopes and then seals and stacks the envelopes. Automatic monitoring ensures the correct number of inserts per envelope.

The system is a sophisticated folding and inserting system which can process large quantities of mail rapidly and easily. The system can be operated by means of a user friendly interface.

The settings of the system (document type, envelope type and fold type) is recorded in jobs. These jobs can be programmed by an authorized user.

The system is equipped with a variety of special features as programmable jobs, including double feed control, hopper swap, multifeed, and daily mail.

2.1 Overview

The system consists of the following areas:

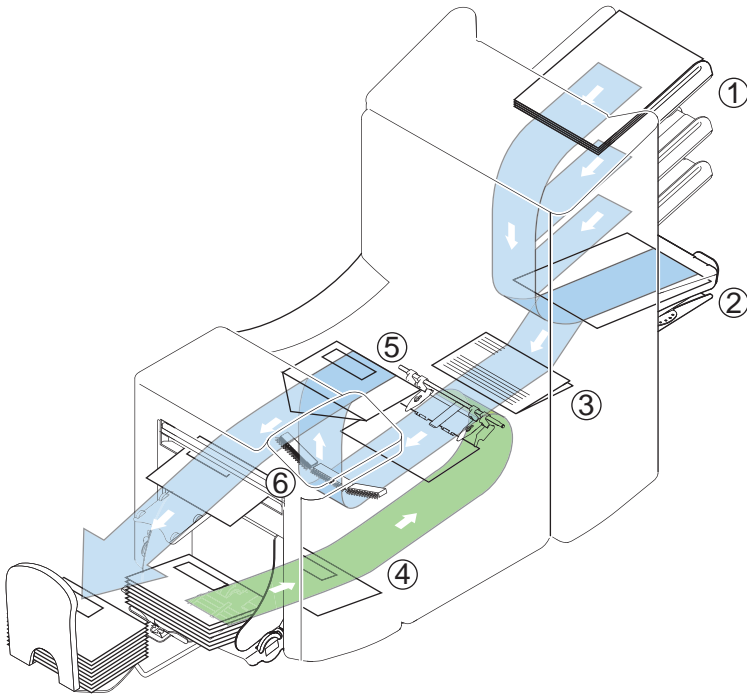

2.1.1 Feeder (1)

The feeder is the feeding part of the system. There are two types of feeders available: the automatic and the special feeder. The automatic feeder does not require any adjustments for the separation. The feeder is equipped with double feed control. In this way the system can detect faulty sets of documents. The feeder is equipped with hopper swap. This means that two feeders can be linked as pairs. When the first feeder is empty, the system switches to the other feeder. Meanwhile the other empty feeder can be refilled without stopping the system. It's also possible to feed multiple documents from one feeder. In this way more documents can be fed from one station, for example an original and a copy of a document.

The upper automatic feeder is equipped with a "daily mail" function for processing documents or sets of documents which cannot be processed automatically (e.g. stapled).

2.1.2 Collating Area (2)

After feeding, the documents are gathered and aligned in the collating area.

2.1.3 Folder (3)

The folder unit folds the documents. The following fold types are possible (see "Terminology" on page 54).

- No fold
- Single fold
- Letter fold
- Zig-zag fold
- Double parallel fold

2.1.4 Envelope Feeder (4)

The envelopes are picked up and transported to the insert position inside the system.

2.1.5 Inserter (5)

After folding the documents are transported to the inserter unit where the documents are inserted into a waiting envelope. The inserter then seals the envelope.

2.2 Operating Controls

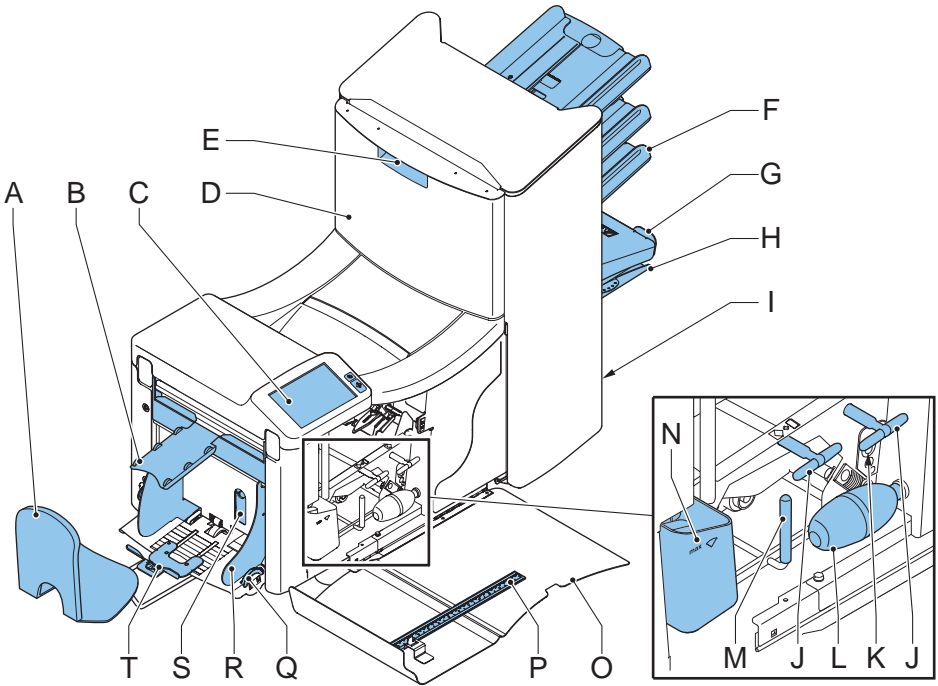



- | | | | |
|---|--|---|---|
| A | catch tray | K | sensors |
| B | envelope slide | L | bellows |
| C | control panel with touch screen | M | unlocking handle for rollers envelope track |
| D | upper unit | N | sealing liquid reservoir |
| E | locking hand grip upper unit | O | side cover (opened) |
| F | document feeder tray | P | ruler |
| G | collator arm | Q | thumb wheel for side guide adjustment |
| H | collating area | R | side guides envelope hopper |
| I | power inlet, power switch, RS232 connector / USB / modem | S | handle for separation adjustment |
| J | handles for clearing jams | T | Envelope support bracket |

2.3 Control Panel

The system has a graphical touch screen.

There are two buttons next to the touch screen:

- : the start key
When the start key is pressed the system starts processing

: the stop key

When the stop key is pressed, the system completes the current set and stops.

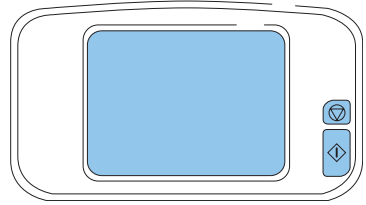

Caution

The touch screen is covered with a thin pressure-sensitive layer. To avoid permanent damage of the touch screen, do not use sharp objects to press on the touch screen.

2.4 Software Description

2.4.1 Home

When you start up the system, the 'home' menu appears. With the arrows you can scroll through the jobs. If you want more information on a job, select the job (see 2.4.2 "Job Description" below).

If you just want to start without job definition, press **New job** and select **Automatic** (see 3.8 "Using an Automatic Job" on page 18).

With the home button  you get back to the 'home' menu.

The **MENU** button opens the main menu (see 2.4.3 "Main Menu" on page 10).



2.4.2 Job Description

If you want more information on a job, select the job in the 'home' menu.

The 'current job' menu shows the following information of the selected job:

- Job number and Job name
- Total: total number of envelopes that have been processed using this job
- To do: number of envelopes to do. Only indicated if a 'stop at' value is set.

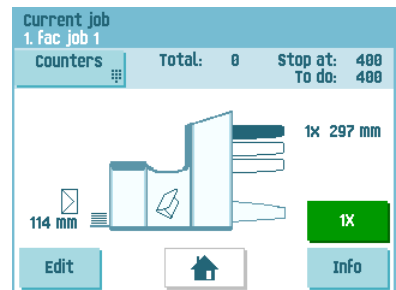

- Stop at: number of processed envelopes at which the system stops. You can set this number with the **Counters** button. You can set it between 0 (switched off) and 9999. The system will continue until the job counter reaches the stop counter value. The system stops and can be restarted. The stop counter is switched off when it is set to zero.

If you want to reset the daily job counter and the stop counter, press the **Reset counters** button in the 'counters' menu.

Note

The counter settings are job related.

- A picture of the system with symbols for the selected features. The following symbols can be used:



Shows the feeders selected to pick documents from (black is selected). Every selected feeder shows how many sheets will be fed from that feeder and the length of the sheets.



This sign indicates that the relevant feeders are linked. This means that when one feeder is empty, the system automatically starts picking documents from the other feeder.



This sign indicates that for the selected feeder OMR or BCR is switched on (optional).



This sign indicates that the relevant feeder is set for daily mail.



Gives information about the envelope size (ISO format or height in mm). An envelope with a cross means that no envelopes are used.



Shows the type of fold, in this case letter fold.



The sign indicates that for the relevant feeder the double feed detection is switched on.

- **Edit** button: use this button to edit the job (see "Edit a Job" on page 27).
- **Info** button: if you press the **Info** button, the screen shows how to position the envelope and documents in the feeders.

From this menu you can press a button to view the reading settings.

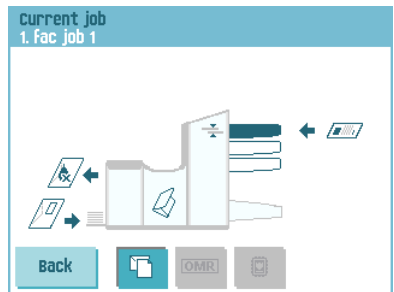

2.4.3 Main Menu

When you press the **MENU** button the main menu appears. This menu allows you to change system settings and define jobs. The screen shows the following functions:

- **Display settings:** change touch screen and volume settings (see "Display Menu" below)
- **Supervisor menu:** change system settings and define jobs (see "Supervisor Menu" below), only for authorized personnel



2.4.4 Display Menu

When you press the **Display settings** button in the main menu, the 'display settings' menu appears.

Use the arrow buttons to adjust the touch screen contrast and the volume of acoustic signals. The figure between the arrow buttons shows the level of contrast or volume.

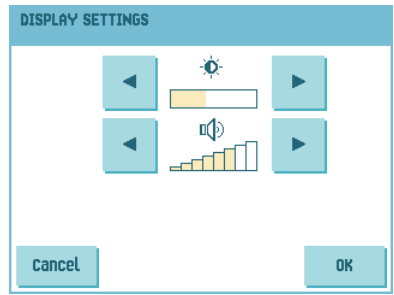

2.4.5 Supervisor Menu

When you press the **Supervisor menu** button in the main menu, a login menu opens. Enter the PIN-code **2546** to access the 'supervisor menu'.

If you enter 3 times a wrong pin code the touch screen shows the main menu again.

When you enter the correct pin code the 'supervisor menu' appears. This menu enables you to check and configure the system and maintain jobs.

The 'supervisor menu' shows the following functions:

- **System info:** shows system information, like:
 - The software versions that are present in the total system
 - The flex certificate, used for reading
 - The counter value since the last service visit
 - The last error generated by the system
- **Options:** shows option information and system information:
 - The chip ID
 - The system ID
 - The installed options

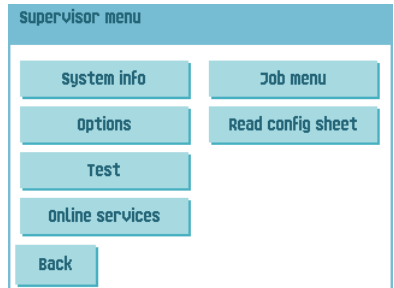

For installing new options, see 5.1 "Activate an Option" on page 29.

- **Test:** opens the 'test menu' (see 2.4.6 "Test Menu," below). Use this menu to test the system.
- **Online services:** opens the 'Online Services' menu (option, see 5.3 "Online Services" on page 36). This menu enables to connect the system to a server and receive messages.
- **Job menu:** opens the 'job menu'. In this menu you can create, edit, copy or delete jobs (see 2.4.7 "Job Menu," below).
- **Read config sheet:** reads Barcode Reading (BCR) settings from a BCR configuration sheet.

2.4.6 Test Menu

Open the 'test menu' from the 'supervisor menu'. Use this menu to check the system, reset all photocells and execute a reading test. The 'test menu' shows the following functions:

- **Diagnostics:** use this function to verify that all motors, clutches and sensors are correctly connected. This test briefly activates the actuators and then measures the current to determine the status of the actuators and clutches.

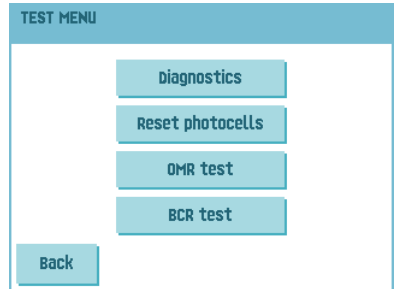

Note

Remove all paper and close all covers before testing.

- **Reset photocells:** used for photocell calibration.
- **OMR test:** use this menu to test the reading head and the quality of the codes on the sheets. Follow the directions on screen.
- **BCR test:** use this menu to test the reading head and the quality of the codes on the sheets. Follow the directions on screen.

2.4.7 Job Menu

When you press the **Job menu** button in the 'supervisor menu', the 'job menu' opens. This menu enables you to create, edit, copy or delete jobs.

The 'job menu' shows the following functions:

- **Create job** (see 4.1 "Create a Job" on page 20)
- **Edit job** (see 4.3 "Edit a Job" on page 27)
- **Copy job** (see 4.4 "Copy a Job" on page 28)
- **Delete job** (see 4.5 "Delete a Job" on page 28)

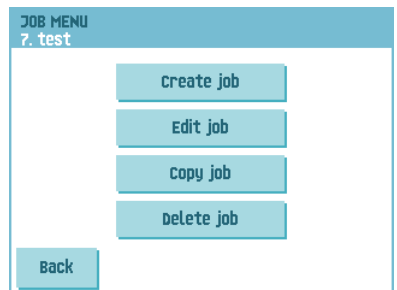

3. OPERATING INSTRUCTIONS

3.1 Installation

Warning

You can severely damage the system if it is connected to the incorrect power supply. Before plugging in the system, check if the local voltage is the same as the voltage mentioned on the type plate.

3.2 Preparation

3.2.1 Document Feeder Trays

Note

The system can be delivered with a tray to manually adjust the separation (special feeder). This tray fits in all positions, but the adjustment is only possible when fitted on the lowest position (position one).

To place the document feeder trays in position:

1. Hold the tray slightly inclined as shown in the figure.
2. Place the front end of the tray underneath the two black rollers.
3. Move the tray upwards (lifting the black rollers), until it is possible to 'hook' the tray into place.
4. Move the tray towards the system and move the hooks over the mounting points (on both sides).
5. Let the tray rest on the system.

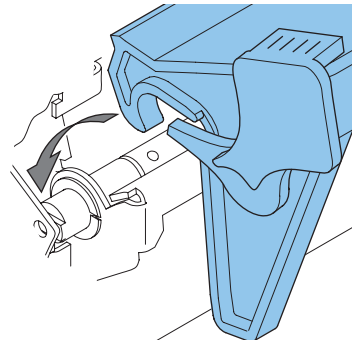
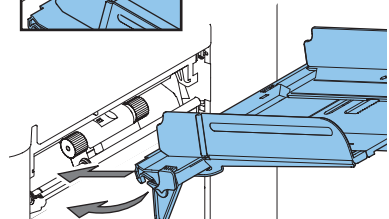
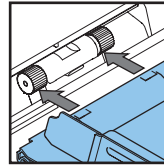

3.2.2 Slide and Envelope Catch Tray

To attach the slide and envelope catch tray:

1. Attach the slide as shown in the figure.
2. Position the envelope catch tray into the holes underneath the envelope hopper as shown in the figure.

The distance **A** should be approximately 1.5 x the envelope height.

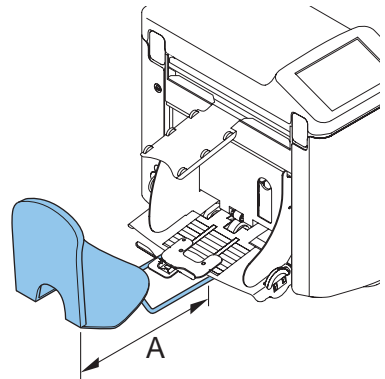
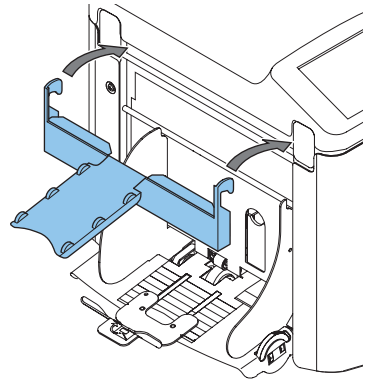

3.3 Starting Up

To start up the system:

1. Connect the system to the mains power supply.
2. Use the power switch to switch the system on. The power switch is located at the back of the system.

The software will ask you to select the required language.

3. Select the required language for the touch screen.

The software will ask you if you want the "select language option" to be displayed every time the system is switched on.















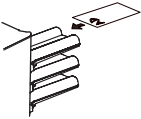
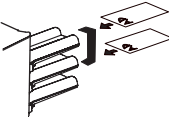
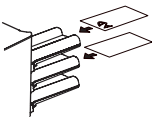
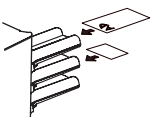

4. Select either **Yes** or **No**.
5. Press the **OK** button. The touch screen shows the home menu.

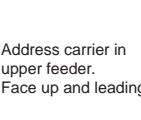
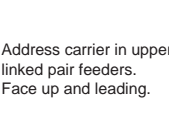
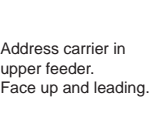
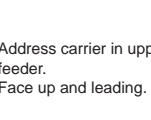

3.4 Loading Documents

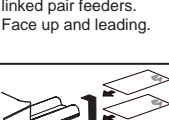
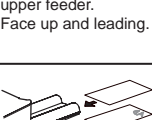
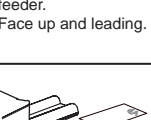
3.4.1 Document Orientation

See also the job information on the touch screen.

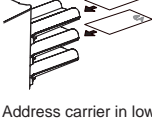
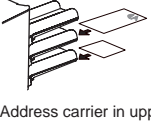
	 one document	 feeder swap	 two documents	 document + enclosure
no fold 				
single fold 				
letter fold 				
double parallel fold 	 Address carrier in upper feeder. Face up and leading.	 Address carrier in upper linked pair feeders. Face up and leading.	 Address carrier in upper feeder. Face up and leading.	 Address carrier in upper feeder. Face up and leading.
zig-zag fold 	 Address carrier face down and trailing.	 Address carrier in lower linked pair feeders. Face down and trailing.	 Address carrier in lower feeder. Face down and trailing.	 Address carrier in upper feeder. Face down and trailing.

3.4.2 Adjusting Side Guides

To adjust the side guides of the document feeder trays:

1. Remove the tray from the feeder as follows:
 - a Push handle **A** downwards.
 - b Lift the tray upwards to unhook it and then pull it out from the feeder.

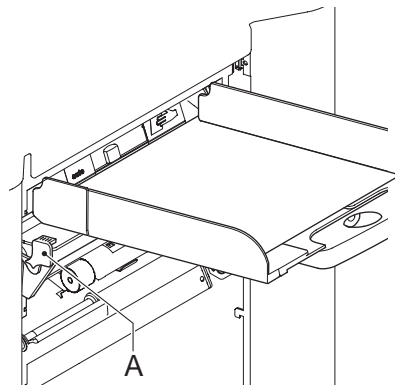

2. Loosen the knob **B** half a turn.
3. Grab the side guides in the middle and push them apart as far as possible.
4. Put a small stack of documents between the side guides.
5. Grab the side guides in the middle and push them towards the documents.

The space between the side guides and the documents should be such that the documents have just enough play to move freely.

6. Re-tighten knob **B**.
7. Remove the stack of documents.
8. Replace the document feeder tray (3.2.1 "Document Feeder Trays" on page 12).

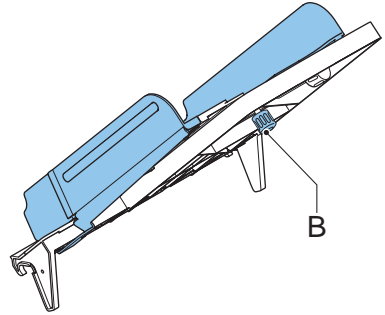

3.4.3 Document Separation

'Document separation' means the adjustment that is required to separate the upper document from the rest of the documents in the stack. This prevents picking up too many documents from the stack at the same time.

The document separation for the *automatic feeders* is set automatically. There are no manual adjustments needed.

Feeder 1 (the feeder in lowest position) can be a *special feeder*. You can manually adjust the separation of special feeders as follows:

1. Remove feeder trays 2 and 3 (the upper trays).
2. Push the knob **B** forward until it clicks.
3. Turn the left-hand side guide **A** downwards.
4. Place a document on the feeder tray and slide it about 60 mm (2.4 inch) into the system. Turn the knob **B** counter clockwise if the separation is set too narrow.
5. Push the document between the separation rollers, which are behind the rubber paper pullers.
6. Turn the knob **B** clockwise to increase resistance or counter clockwise to lower the resistance.

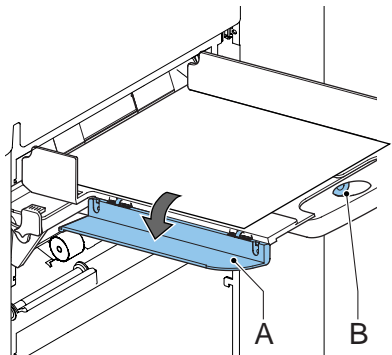

The separation is adjusted correctly when a slight resistance is felt on the document.

7. Pull the knob **B** back again when ready.
8. Close the left-hand side guide.

3.4.4 Filling the Document Feeder Tray

To fill the document feeder tray:

1. Turn the left-hand side guide **A** downwards.
The feed rollers are lifted automatically.
2. Place a stack of documents between the side guides.
Feed the documents (depending on the type of documents and the type of fold) as shown in 3.4.1 "Document Orientation" on page 14.
3. Turn the left side guide upwards again.

3.5 Loading Envelopes

To load the envelopes:

1. Adjust the side guides **C** with thumb wheel **D** so, that the envelopes:
 - Fit exactly between the side guides
 - Can move freely

Note

If the distance between the side guides is too large, the envelopes will twist sideways, when transported into the system.

Note

If you use the optional High Capacity Vertical Stacker, also adjust the side guides of this stacker (see "Adjusting the Side Guides" on page 42).

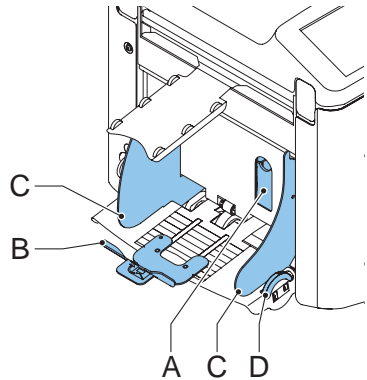

2. Set the envelope separation as follows:
 - a Pull down small lever **A**.
 - b Insert one envelope horizontally up to the stoppers.
 - c Return lever **A**.
3. Place the bottom envelope between the rollers (flap down and trailing - bottom side of envelope pointing to the system).
4. Loosen the stack of envelopes and place the stack on top of the bottom envelope.

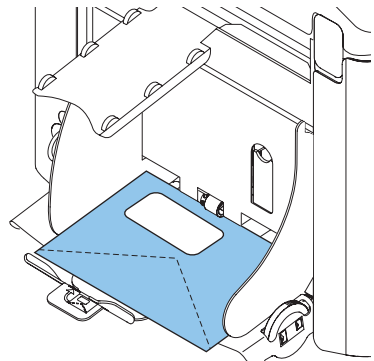

- Shift envelope support **B** in or out, so that the top side of the envelope lies against the dotted line on the support.
- Turn envelope support **B** so the weight of the envelopes is distributed evenly on both sides.

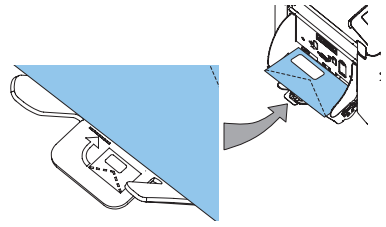

3.6 Filling the Sealing Liquid Reservoir

When you want to seal envelopes, the sealing liquid reservoir must be filled.

- Open the front cover **A**.
- Fill the reservoir **B** up to lip **C** with sealing liquid.
- Close the front cover **A**.

Before you start the job, wait approximately 5 minutes for the brushes to moisten.

If the liquid reservoir is almost empty the touchscreen shows a message to warn you that you should refill the reservoir.

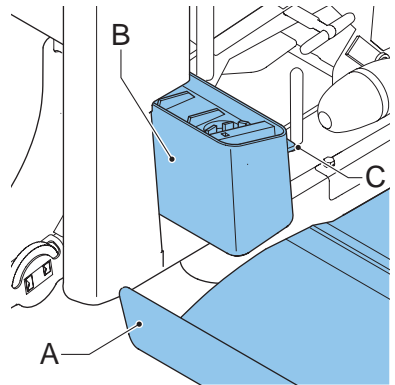

3.7 Run a Job

To run a job:

- From the 'home' menu select a job.
If you press the **OK** button, the job information appears (see "Job Description" on page 8).
- Load envelopes as specified in the job. Press the **Info** button for details.
- Load the documents face up and leading, as specified in the job. Press the **Info** button for details.
Place the address carrier in the upper feeder.
- Press the **1x** button to start a test run or press the  button to start the job.

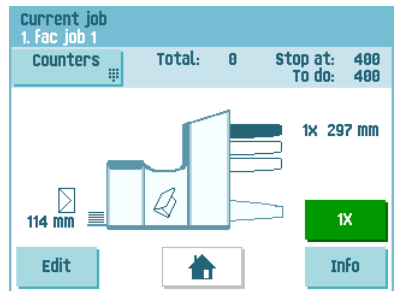

If you press the **1x** test button, the screen shows questions that help you to solve any problems on mail set quality. If necessary this troubleshooting wizard helps you to:

- adjust envelope position (see 7.3.1 "Insert Position" on page 49)
- adjust finger position (see 7.3.2 "Envelope Insert Fingers" on page 49)
- adjust address position (see 7.3.3 "Address Position" on page 49)

3.8 Using AutoSet

If you do not want to define a job and just want to do some inserts, you can let the system determine the job settings for you.

This 'automatic' job determines automatically its job settings by measuring the sizes of documents and envelope. One sheet will be taken from all feeders that are loaded. Based on the maximum document length (which is also the length of the document set) and the length of the envelope, the fold type is determined.

Note

AutoSet cannot be used together with linked feeders, multifeed, daily mail and reading functionality.

The AutoSet is not possible in the no envelopes mode or with usage of envelopes with open flap.

In AutoSet only the Double Feed Control (DFC) of the upper feeder is selected.

Note

Before starting an AutoSet job, be sure that no documents or envelopes are left in the system.

To start an AutoSet job:

1. From the 'home' menu, press the **New job** button.
2. Press the **Automatic** button.
3. Load envelopes.
4. Load the documents face up and leading.
Place the address carrier in the upper feeder.
5. Press the **1x** button to start a test run (see 3.7 "Run a Job" on page 17) or press the  button to start the job.
6. If you press the **Save** button you can copy this job to a job number.

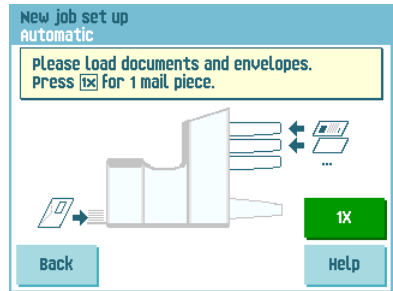

3.9 Daily Mail

To process documents or sets of documents, which can not be processed automatically (e.g. stapled documents), the top feeder is equipped with a daily mail switch.

To use the Daily Mail function:

1. Select a job where the daily mail function is selected. You can recognize the daily mail by the  icon in the job information menus.



2. Turn down the left side guide **A** of the upper tray.

Now you can see the Daily Mail handle **B**

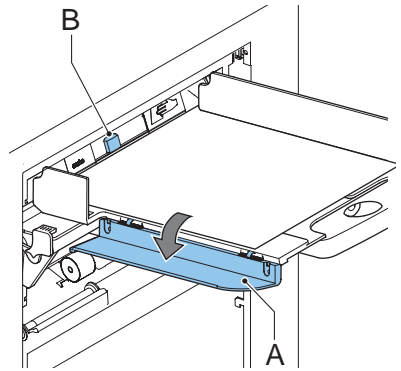

3. Move the handle to enable the Daily Mail function.
4. Place the document or document set in the feeder (see "Filling the Document Feeder Tray" on page 16) and turn side guide **A** upwards.



5. Press the  button to start the job.
The document or document set will be folded and inserted into the envelope as described in the selected job.
6. Place the next document or document set in the feeder. The system will keep running to process the inserted document or document set.
7. When finished with Daily Mail, press the  button to stop the job.
8. Set the Daily Mail handle **B** to the 'AUTO' position to disable the Daily Mail and enable the automatic document separation.

3.10 Stopping the system

To stop the system press the  button. The system completes and inserts the current set and stops. This results in a cleared system which is ready to process a new job.

4. JOB PROGRAMMING

4.1 Create a Job

To create a new job:

1. From the 'home' menu, press the **New job** button.
2. Press **Manual** to create a new job.
For **Automatic**, see "Using AutoSet" on page 18.
3. Enter the pin code **2546**.

4. Press **Wizard** to create a new job with the job creation wizard or press **Advanced** (experienced users only).

If you use the job creation wizard, follow the steps on screen. The system stores the new job under the lowest free job number.

You can manually select a free job number to save the new job. The screen will show the lowest free job number.

If you use the advanced way of job programming, continue as follows:

5. Press **OK** to confirm the selected free job number.

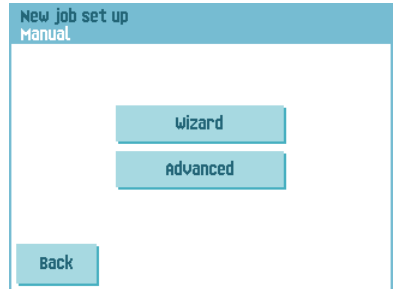

Note

A new selected job number starts with default settings.

The 'job settings' menu opens. The meaning of all buttons and settings is explained in 4.2 "Job Settings" on page 21.









6. Press **Save** to save the job with the entered settings under the specified job number and name.

To name a job, see 4.2.6 "Job Name" on page 26.

7. Press the **1x** button to verify that the insert position and address position are correct (see 7.3.1 "Insert Position" on page 49 and "Address Position" on page 49).

4.2 Job Settings

From the "job settings" menu the following settings are available:

-  Envelope settings (see 4.2.1 "Envelope Settings," below)
-  Document settings (see 4.2.2 "Document Settings" on page 22)
-  Fold settings (see 4.2.3 "Fold Settings" on page 24)
-  Reading settings (if installed) (see 4.2.4 "Reading Settings (Option)" on page 25)
-  Double feed control settings (see 4.2.5 "Double Feed Control Settings" on page 26)
-  Job name settings (see 4.2.6 "Job Name" on page 26)
-  Mailing/Frinking settings (if installed) (see 4.2.7 "Mailing/Frinking Settings (Option)" on page 27)
-  Mail Piece Production Control (MPPC) settings (if installed)
See the appendix operator manual Mail Piece Production Control

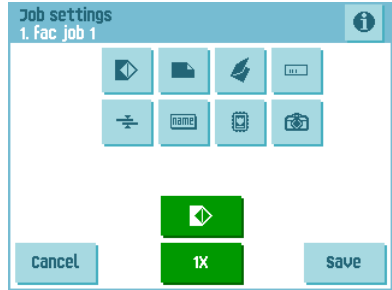



If you want to view the job details of the current job, press the  button. If you want to run a test set or test envelope, you can use the green buttons in this menu.

4.2.1 Envelope Settings

In the 'envelope settings' menu you can define the envelope properties and switch the sealing on and off.

In the top of the screen, three selection buttons are displayed, from which one can be selected. The selected settings button will be highlighted.

- Press  to select an envelope with closed flap. This means that the envelopes are fed with closed flap. Use the upper  button to enter the applicable dimensions.

It is also possible to select ISO standard envelopes or dimensions in inches (depends on the installation settings).

The envelope height can be set between 90 mm (3.5 inch) and 162 mm (6.38 inch).

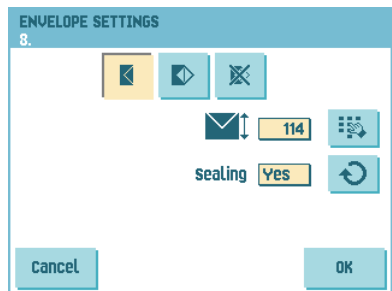



Use the  button to switch automatic envelope sealing on, off or use reading (in case of a job with reading settings, see "Sealing Control" on page 34).

- Press  to select an envelope with open flap. This means that envelopes are fed with open

flap. Use the upper  button to enter the applicable dimensions. The envelope height can be set between 90 mm (3.5 inch) and 162 mm (6.38 inch).

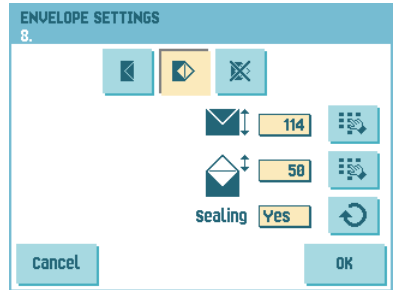
It is also possible to select ISO standard envelopes or dimensions in inches (depends on the installation settings).





Use the second  button to enter the flap height. The flap height can be set between 32 mm and the envelope height minus 32 mm (1.26 inch).

Use the  button to switch automatic envelope sealing on or off.

- Press  to define a job without inserting the documents in envelopes (no envelope mode). This can be useful for jobs, where documents only have to be sorted and/or folded.

4.2.2 Document Settings

In the 'document settings' menu you define the document formats and the number of documents that must be picked from the different feeders.

- Press  to set the number of sheets for the different feeders.
 - Press  to select a feeder. The selected feeder is highlighted.
 - Press the arrows to change the number of sheets that must be picked from the highlighted feeder. When the number of documents is 0, the selected feeder will be deselected.

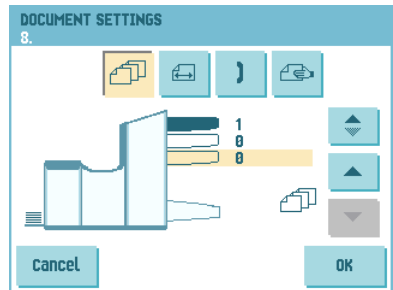



Note

When a feeder is set to daily mail the number of documents is always 1 and can not be set in this menu.



Note

The maximum number of sheets in a set is 25. When folding is used the maximum set thickness is 8 sheets in letter fold and 10 sheets (80 gr./m²) in single fold.

- Press  to enter the document height. The height or the ISO format of the document will be displayed next to the relevant feeder.
 - Press  to select a feeder. The selected feeder is highlighted.
 - Press  to show a numeric keypad to enter the exact dimension of the document.

Dimensions can be entered in mm, inches or as standard ISO paper dimensions (depending on installation settings). The system will not allow entering dimensions out of technical ranges. The document size can be set between 90 mm (3.54 inch) and 356 mm (14 inch).

The default document size setting of a new job is 297 mm (11.7 inch).

- Press  to link two feeders. This function enables to fill two adjacent feeders with the same documents. When the first feeder is empty, the system automatically swaps to the other feeder.
 - Press  to select two adjacent feeders. The selected feeders will be highlighted.
 - Press  to link two highlighted feeders.

The  will be displayed between the selected feeders.

Note



When linking two feeders, the program will automatically apply the number and format of the documents of the lowest feeder to the other feeder.

Note

When a feeder is selected for reading, the feeder below can not be linked to this reading feeder. The reading feeder can be linked to a feeder above when it is not selected for selective feeding.

- Press  to enter the setting of the daily mail function.

This function enables to process documents or sets of documents, which can not be processed automatically (see 3.9 "Daily Mail" on page 18). The upper feeder is automatically selected.

- Press  to enable the daily mail function. The icon  appears behind the upper feeder. If you press  again the daily mail function will be disabled.

Note

The daily mail function is only available when reading is not activated. When daily mail is set, the links to the daily mail feeder will be deselected automatically.





Note

When the daily mail function is selected Double Feed Control is not available.

4.2.3 Fold Settings

In the 'fold settings' menu you can adjust the folding dimensions and folding type.

Select the fold type. The following choices are available:

-  No fold (no settings required)
-  Single fold
-  Letter fold
-  Double parallel fold
-  Zig-zag fold

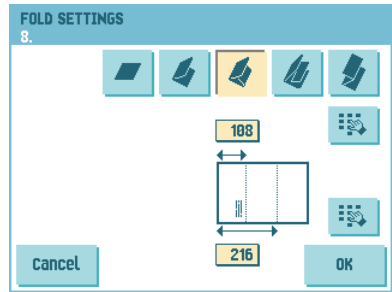

Except when no fold is required, the touch screen shows a simple diagram of the

document with the fold positions. To change the fold positions press  next to a fold. Enter the required position of the relevant fold.

Fold type		Minimum position	Maximum position
Single fold		75 mm (2.95")	Longest document length minus 25 mm (0.98")
Letter fold	First fold	75 mm (2.95")	Longest document length minus 50 mm (1.97")
	Second fold	Position first fold plus 26 mm (1.02")	Longest document length minus 25 mm (0.98")
Zig-zag fold	First fold	75 mm (2.95")	Longest document length minus 100 mm (3.94")
	Second fold	Position first fold plus 25 mm (0.98")	Longest document length minus 75 mm (2.95")
Double parallel fold	First fold	75 mm (2.95")	Longest document length minus 51 mm (2.0")
	Second fold	Position first fold plus 25 mm (0.98")	Longest document length minus 25 mm (0.98")

Note

The touch screen will indicate when entered positions are out of range.

4.2.4 Reading Settings (Option)

For a full function description of reading, see 5.2 "Reading" on page 29. In the 'reading settings' menu it is possible to enable or disable the Optical Mark Recognition (OMR) or Barcode Reading (BCR) function and to adjust the basic settings.

The first 'reading settings' menu covers the following settings:

- Code type: default is the setting 'none': reading is disabled.

Change the setting with the  button. The following codes are possible:

- 1-track OMR codes
- BCR for reading barcodes
- Flex 1-9 for reading customer specific codes (only if flex dongle is installed)

- Read from feeder: press the  button to select a feeder to activate reading on.

By pressing the  button the next reading settings menu appears. This menu covers the following settings:

- 1st mark from top: press  to set the position of the first optical mark, measured from top of the sheet. The value can be varied between 15 mm (0.6 inch) and 277 mm (10.9 inch). If you selected BCR, a second keypad is available to enter the length of the code.
- Max. sheets: use the arrow buttons to select the maximum amount of sheets in the set of documents.

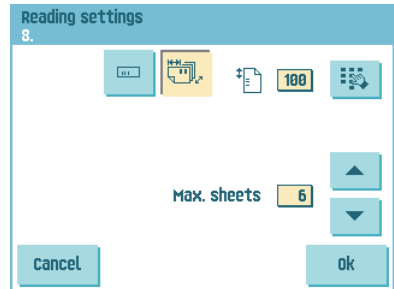
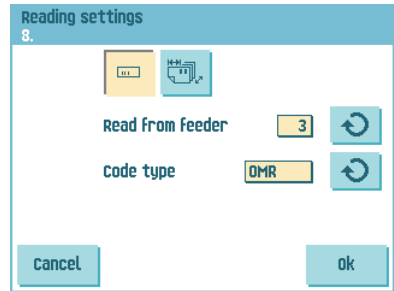

Note

The maximum number of sheets in a set is 25. When the number of sheets exceeds 8 or 10, depending on the fold, the document can not be folded anymore. In this case, the maximum length of sheets is 148 mm for a C5/6 envelope. Also make sure that the fold is set to No fold.



Ignoring this will certainly lead to stoppages.

When the maximum number of sheets exceeds the programmed maximum number of sheets in a set, the system stops and error INS-RE-14 will be displayed. After removing the set and pressing the **Reset** button, the system will start and repeat the process until an insert or divert mark is encountered, error INS-RE-15 (final set part) will be displayed.

4.2.5 Double Feed Control Settings

In the 'DFC settings' menu you can set Double Feed Control (DFC) for the different feeders on or off.

To set the DFC for the different feeders:

1. Press the  button to select a feeder.
2. Press the  button to switch the DFC on or off. When switched on, the  icon is displayed.

When a job is started, the first document taken per feeder is used for a reference measurement. When a document is exceeding that reference thickness an error will be displayed.

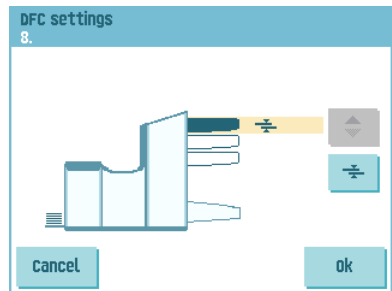



Note

When Daily mail is selected, the DFC will be switched off automatically.

4.2.6 Job Name

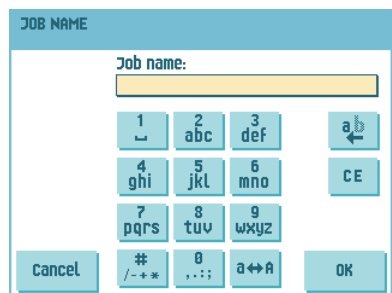

It is possible to store the job with a meaningful job name, to easily recognize the job. This name is displayed at job selection. Enter a job name with the alpha-numeric keypad.

- Use the  button to clear a character left of the cursor position (backspace).
- Use the  button to clear all entered characters and start again.



4.2.7 Mailing/Frinking Settings (Option¹)

If this system is connected to a mailing/franking system, this option allows you to select the franking mode. The 'franking settings' menu has the following options:

- Franking: use the  button to switch between
 - Yes (franking on)
 - Pass through (franking off)
- Value defined by: use the  button to switch between:
 - Franking machine: the mailing (franking) system will print/frank the envelopes according to the local mailing (franking) system settings. To link a mailing (franking) job to the inserter job, use the arrow buttons to select a job. If no link is required, select 'Current job'.
 - Inserter: the mailing (franking) system will print/frank the envelopes according to the size data communicated by the inserter.

If you press the **Next** button a menu appears via which the weight of single documents and envelopes and the envelope width can be entered. Use the **Weight settings** and **Envelope width** buttons to enter these data.

To link a mailing (franking) job to the inserter job, use the arrow buttons to select a job. If no link is required, select 'Current job'.

Refer to the appendix for an extensive description of the mailing (franking) option.

4.3 Edit a Job

To edit an existing job:

1. From the 'home' menu, select a job you want to edit.
2. Press the **Edit** button.
3. Enter the pin code **2546**.

The 'job settings' menu opens. Refer to 4.2 "Job Settings" on page 21 for the meaning of all buttons and settings.

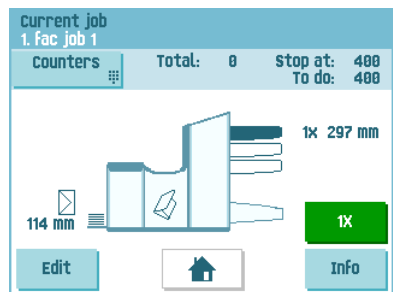
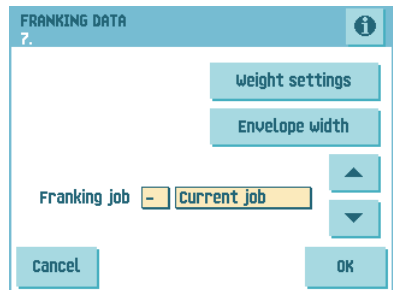
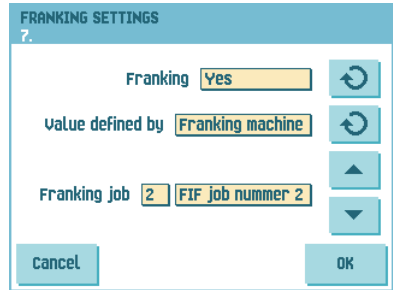

1. Ask your supplier if this option is available for your mailing/franking system.

4. Press **Save** to save the job with the entered settings under the specified job number and name.

To name a job, see 4.2.6 "Job Name" on page 26.

5. Press the **1x** button to verify that the insert position and address position are correct (see 7.3.1 "Insert Position" on page 49 and "Address Position" on page 49).

4.4 Copy a Job

To copy existing job settings to a new job:

1. Press the **Supervisor menu** button from the main menu.
2. Enter the pin code **2546**.
3. Press the **Job menu** button.
The 'job menu' opens.
4. Press the **Copy job** button.
The 'copy job' menu appears.
5. Press the arrows if you want to select another job number to copy from or to copy to.

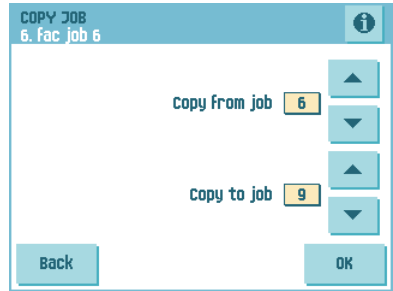

Note

You can only copy job settings to new jobs.

6. Press **i** for details of the job to copy from.
7. Press **OK** to copy the job settings.

If all jobs are programmed the touch screen shows "No more free jobs".

It is possible to copy an Automatic job into a job. Before an Automatic job can be copied, it has to be defined successfully (see 3.8 "Using an Automatic Job") on page 18).

4.5 Delete a Job

To delete an existing job:

1. Press the **Supervisor menu** button from the main menu.
2. Enter the pin code **2546**.
3. Press the **Job menu** button.
The 'job menu' opens.
4. Press the **Delete job** button.
The 'delete job' menu appears.
5. Select a job number and press **OK**. The job will be deleted without a warning.

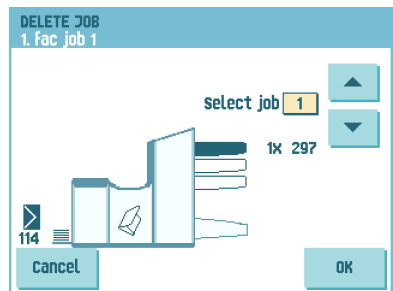

5. OPTIONS

5.1 Activate an Option

To activate a new option:

1. From the 'supervisor menu' choose **Options**.

Software options are enabled with license codes. These license codes, together with the identification number of the system enable the relevant options. The enabled and available software options are displayed in this menu. Contact your dealer for information about these license codes.

2. Press **Add** to activate other software options.
3. Enter the license key code that you received from the supplier to activate the relevant option on this system.

Use the arrow keys to navigate through the entered characters.

4. Press **OK** to confirm the license key and to return to the 'options' menu.
5. Switch the system off and on.

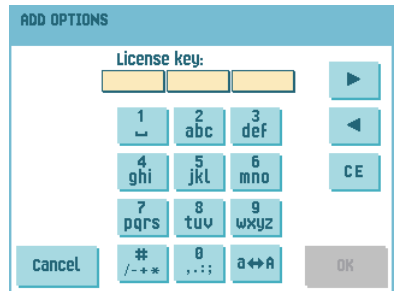

5.2 Reading

5.2.1 Introduction

The folding and inserting system can be equipped with reading. This allows the system to read special codes that have been printed on the documents. These codes contain information about the processing of the sheets. Two types of codes are available:

- OMR: Optical Mark Recognition
- BCR: Bar Code Recognition

The sheets with the printed code are placed in the reading feeder. Depending on the programmed code, the other feeders can be used as selective feeders to add enclosures.

In case of a zig-zag fold, the address has to be printed on the last page of the set. With the other fold types, the first sheet of a set always contains the address. A full length code is printed on every sheet of a set. The code must appear in the same location on every page regardless of the actual code length.

The code on the last sheet of the set contains the insert instruction. The other sheets carry the accumulate instruction. If a parity check is used with OMR, this is checked on each sheet. If the "page n of m" code is used with BCR, the set will be inserted when n equals m.

Both reading options can be enabled with a special license code (refer to "Activate an Option" at top of this page).

5.2.2 Adjust Reading Head Position

The horizontal position of the reading head must be adjusted to the same position of the printed marks on the documents.

To adjust the reading head, proceed as follows:

1. Fold a document with reading code on the first mark.
2. Open the upper unit (see page 7).
3. Hold the document in the middle against the ruler.
4. Shift the reading head **A** so it is positioned exactly above the middle of the reading marks.
5. Divide the paper guides **B** along the width of the document.

Note



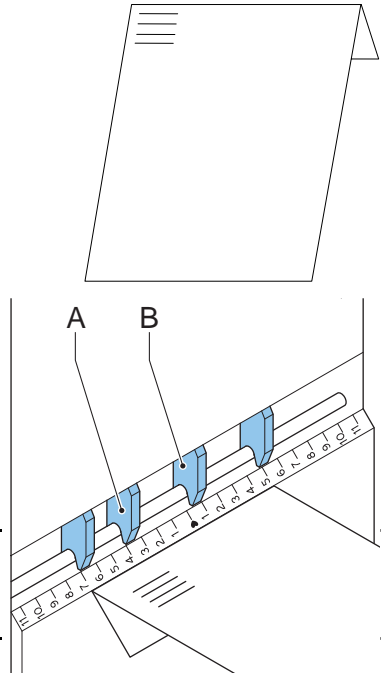



When the reading head is adjusted it is possible that paper guides have to be removed and placed on the other side of the reading head.



5.2.3 Document Orientation

Switch on the reading function and set the position of the reading marks as described in "Reading Settings (Option)" on page 25.

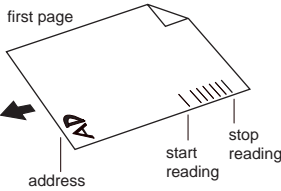
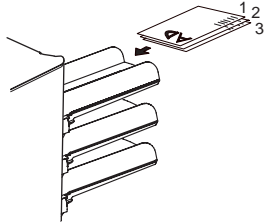
Document orientation:

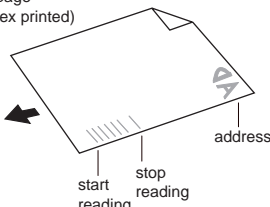
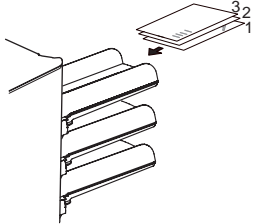
Fold type	Type of documents	Loading positions
<p>no fold </p> <p>single fold </p> <p>letter fold </p> <p>Double parallel fold </p>	<p>first page</p> 	 <p>Address carrier, face up and leading.</p>
<p>zig-zag fold </p>	<p>last page (duplex printed)</p> 	 <p>Address carrier, face down and trailing.</p>

5.2.4 Reading Codes

Printing Quality

- Marks should be printed in black.
- Marks on the same sheet must have equal intensity.
- Marks must be printed on the same position on every sheet.
- For matrix printers near letter quality (NLQ) printed characters are preferred to obtain maximum blackness (double strike).
- Be aware of background "noise". Color changes on the form, background design, a logo or copy on the opposite side of the sheet that will bleed through can be read by the reading head, causing disturbances of the reading function.
- The ribbon or toner quality must be checked before printing.

BCR Code Specification

Minimal distance from top of sheet to first bar	15 mm (0.59 inch)
Minimal distance from bottom of sheet to last bar	30 mm (1.18 inch)
Minimal distance from side edges of sheet to barcode	7 mm (0.28 inch)
Minimal free space above and below the barcodes	8.5 mm (0.33 inch)
Minimal free space on both sides of the barcodes	4.2 mm (0.17 inch)
Minimum height of a bar	9 mm (0.35 inch)
Minimum line thickness of a bar	0.25 mm (0.01 inch)

The length of the code is a job setting. The code must appear in the same location on every page.

Minimum Code/Basic Commands

In case of OMR the minimum code is one mark in one line (insert). However for reliability it is advised to use at least 2 marks. The first line is the start mark. A mark printed on the second line means insert. No mark on the second line means accumulate.

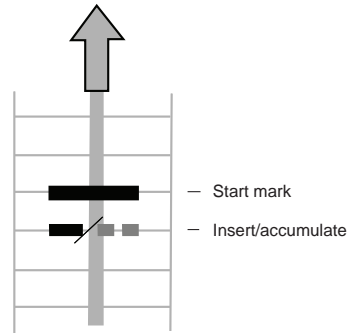

Note

In some cases, on request of the customer, the reading of the basic commands can be reversed by the service organization. This means that no mark is interpreted as an insert command and that for the accumulate command a mark has to be printed.

In case of BCR the minimum codes are also for accumulate and insert.

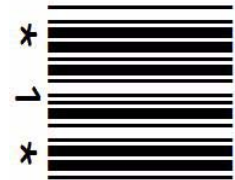

Additional Codes

When it is required to control more functions in the inserter system, additional codes are available.

The following additional functions are possible via software options:

- Divert
- Stop
- Selective feed from station 1
- Selective feed from station 2
- Selective feed from station 3
- Sealing control
- Sequence check 4, 2 and 1 (respectively with 1, 2 or 3 marks, only OMR)
- Parity check mark (even, only OMR)
- Safety mark (only OMR)

General remarks:

- In case of OMR the marks must always be used in the above sequence.
- If a function is suppressed the following function will move upwards one line.
- The chosen code must always be used on all material processed by reading.
- The mark definition is a service setting (OMR).
- Other functions are possible via special codes (Flex codes)

Divert

The system stops, manually remove the set from the collator. Reset and start again.

Stop

The system stops, manually remove the set from the collator. Reset and start again.

Selective Feed

The system will selectively feed an enclosure when commanded so.

Sealing Control

When the 'sealing control' mark is printed, sets will not be sealed. When no 'sealing control' mark is printed, sets will be sealed.

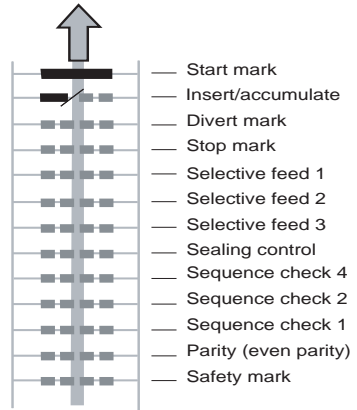

Sequence Check (only OMR)

Sheets in a stack can accidentally get out of sequence or can be missing. This can be detected by the system when the sequence function is used. Each sheet has a number that forms part of the reading code.

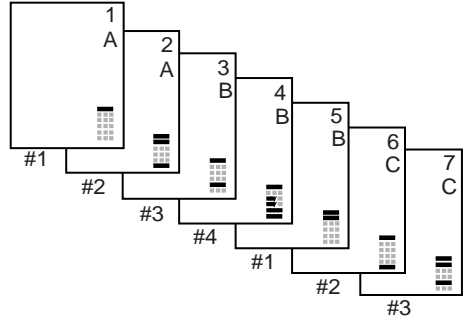

These are the available possibilities:

- 1 mark: pages are numbered 1-2-1-2-1-etc.
- 2 marks: pages are numbered 1-2-3-4-1-2-3-4-1-2-etc. (see figure)
- 3 marks: pages are numbered 1-2-3-4-5-6-7-8-1-2-3-etc.

The table shows examples of sequence check.

Marks on the sheets:	sheet count							
	1	2	3	4	5	6	7	8
Sequence check 4 (3 marks used)	-	-	-	-	-	-	-	-
Sequence check 2 (2 marks used)	-	-	-	-	-	-	-	-
Sequence check 1 (1 mark used)	-	-	-	-	-	-	-	-

■ = Mark printed, □ = No mark printed

Note

If you use sequence control and the system stopped, you can reset the sequence counter as follows: press the  (stop) button and press the **Yes** button to confirm.

Parity Mark (only OMR)

By adding a parity mark the reading code can be checked. When the OMR advanced package is used the sum of the marks has to be even.

Safety Mark (only OMR)

The safety mark is used as an extra security. With skewed paper the reading head can miss part of the reading code. In these situations the safety mark is not read, and the system will give an error.

The safety mark also indicates the end of the reading code.

This mark must always be present on the document if it has been activated as an OMR code.

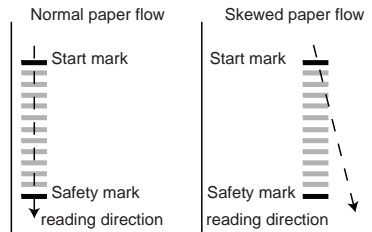

Page n of m (only BCR)

BCR uses the code 'page n of m' to complete a set. If n is less than m, the sheets are accumulated. If n = m, this is the last sheet of the set and the set will be inserted.

Example of OMR Code

In the figure the legend for the following example is shown. In this example feeder station 3 is the reading feeder. The feeder stations 1 and 2 are selected for selective feeding.

In this example, a set of 8 sheets with two selective feeds (station 2 and 1) and three sequence check marks is shown.

- The first position is used for the start mark which must be printed on every sheet.
- The second mark position is used for the insert/accumulate command. The mark is printed on the last sheet of the set (inserting is required).
- Position 3 and 4 are reserved for selective feeding from station 2 and 1. Print a mark on position 3 when a selective feed from station 2 is required. Print a mark on position 4 when a selective feed from station 1 is required. The marks are printed on the last sheet of the set.
- Position 5, 6 and 7 are used for the sequence check marks. The meaning of the sequence check marks is explained in section "Sequence Check (only OMR)" on page 35.

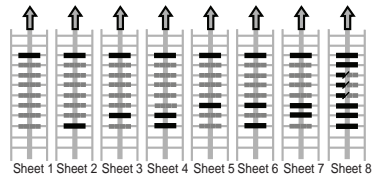
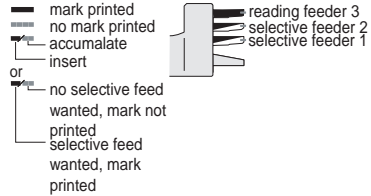

5.3 Online Services

The folding and inserting system can be equipped with Online Services. This option enables the system to connect to a central server. During the connection data is downloaded to and uploaded from the system. The system always initiates the connection, it is not possible to make a connection from outside to the system. Ask your supplier if this option is available.

5.3.1 Start-Up Online Services

To start-up Online Services:

1. From the 'supervisor menu' choose **Online services**.

The 'Online Services' menu shows the following functions:

- **Connection**: opens the 'connection' menu to create a connection to a central server and to view the connection history (see "Connection" on page 37).

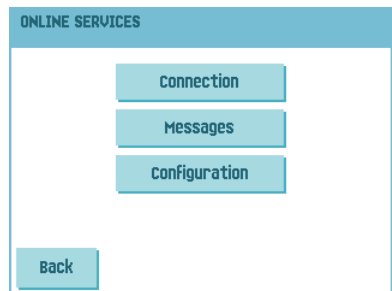

- **Messages:** opens the 'messages' menu to view received messages (see "Messages" on page 37).
- **Configuration:** opens the 'configuration' menus to change Online Services settings (see "Configuration Menu" on page 38).

Connection

The system makes a connection on fixed times. It is possible that you manually connect the system to the server. To connect to the server:

1. Press **Connection** in the 'Online Services' menu.
The touch screen shows the 'connection' menu.
2. Press **Connect** to manually connect the system to the OLS server.

You can view the status of the connection on the screen. The text on the button changes to **Disconnect**.

Press **Disconnect** to terminate connection with the server.

The 'connection' menu shows the following functions:

- **History:** opens the 'history' menu to view the connection history (see "History" on page 37).
- **New messages:** this button appears when the system received new messages and opens the 'messages' menu (see "Messages" on page 37).

History

The 'history' menu shows previous connections of the system to the server.

1. Press the arrows to select a previous connection.
2. Press  to view details on selected previous connection.

Messages

After pressing **Messages** in the 'Online Services' menu the touch screen will show messages received from the server. A message has content like a new job or new software.

1. Press the arrows to select a message.
2. Press  for more information over a selected message.

In case a new job or new software can be installed the **Continue** button appears.

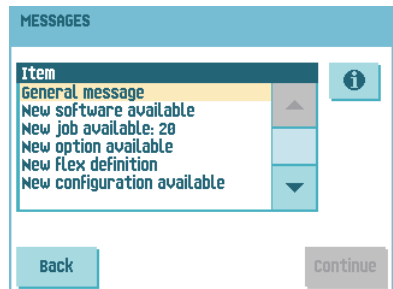
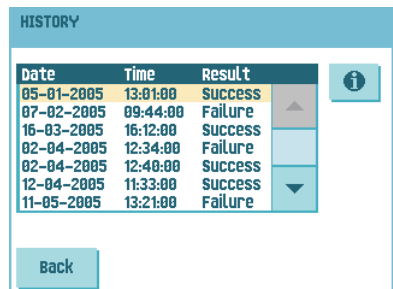
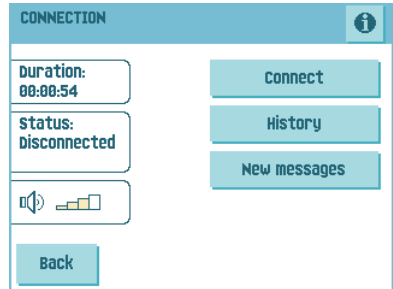

To install a new job or new software:

1. Press **Continue**.

The 'new job available' menu or 'new software' menu appears. Press  for more information on the new job or new software.

2. Press **Install** to install the new job or new software or press **Reject** to reject it.

After pressing **Install** a confirmation menu opens:

- In case of a new job press the arrows to select a free job number (see 4.1 "Create a Job" on page 20).

Press **OK** to confirm the selected job number or press **Cancel** to return to the 'new job available' menu.

- In case of new software press **OK** to confirm the installation or **Cancel** to return to the 'new software' menu.

After confirming the installation of the new job or new software the 'message' menu appears.



Configuration Menu

After pressing **Configuration** in the 'Online Services' menu the 'configuration' menu opens. Use this menu to modify the OLS settings.

The menu consists of two submenus containing the following functions:

- Telephone number of server: contact your supplier for the telephone number of the OLS server.

To change the number:

- a Press 
 - b Enter the correct number using the numeric keypad.
 - c Press **OK** to confirm the new number.
- Prefix: use this function in case you need to dial a certain number or string to access an outside line.
 - a Press 
 - b Enter the correct prefix using the numeric keypad.
 - c Press **OK** to confirm the new number.
 - Country: use the arrows to select a country from where you are dialing.
 - Date and time: enter the current date and time.
 - a Press 
 - b Enter the correct date and time using the numeric keypad.
 - c Press **OK** to confirm the new date and time.



CONFIGURATION 1/2

Telephone number: 0031 512 589300

Prefix: prefix

Country: Netherlands

Buttons: Cancel, <>, OK

- Dial tone detection on / off

This setting is required if no dial tone is heard during establishing a connection. The default value is on. This setting is relevant to some PABX telephone switch systems.

Press  to switch the dial tone detection on or off.

- Volume of modem: set the modem volume.

- Press  to change the volume of the speaker.
Do not set the volume to zero as the sound of the modem is helpful during remote assistance.

Press **OK** to confirm modified settings.

5.4 Production Feeder (MF-2)

5.4.1 Function

The Production Feeder is a feeder that can be loaded with a high number of documents. This feeder is intended to be used for Business Reply Envelopes (BRE), but also 'standard' documents up to 156 mm (6.1") length can be processed with it.

5.4.2 Preparations

The Production Feeder should be installed at the position of feeder no. 1.

It can be placed into position in the same way as the other document feeders.

Proceed as follows:

1. Lift the paper feed rollers with the front edge of the Production Feeder.
2. Move the Production Feeder forward until it hooks behind the frame axle.
3. Connect the connector **A** to the socket **B**.

The Production Feeder is auto-detected by the system when the system is switched on. This makes it easy to switch over from the standard document feeder tray to the Production Feeder and vice versa.

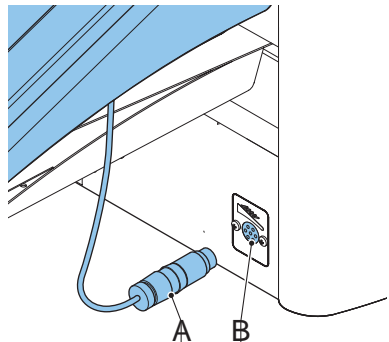

Note

To allow easier hooking on of the Production Feeder it is advised to put the feeding plate in the rear position (see 5.4.4 "Document Separation" on page 40).

To use the Production Feeder it is not necessary to (re-)program the jobs.

5.4.3 Adjust Side Guides

Adjust the side guides:

1. Take a stack of documents/BREs and place them in the feeder tray.
BREs with flap down and leading (top side pointing to system).
2. Adjust the side guides by turning the thumb wheel **G** so the documents/BREs just fit and can move without resistance.
Too much play causes skewing.

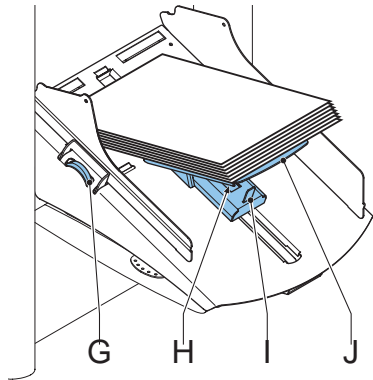

5.4.4 Document Separation

When the Production Feeder is used as an automatic separation feeder, the separation is set automatically.

The Production Feeder can also be used on a feeder position with a manually adjusted separation.

To adjust, proceed as follows:

1. Remove feeders 2 and 3.

Note

The lowest feeder is feeder 1.

2. Squeeze the two blue handles **C** and **D** and shift the feeding plate **F** as far as possible to the front.
3. Push knob **E** forward until it clicks.
4. Place a document/BRE on the feeder tray and slide it in the system till the leading edge is not visible anymore. Turn knob **E** counterclockwise if the separation is set too narrow.
5. Push the document/BRE between the rollers.
6. Turn knob **E** clockwise to get more resistance and counterclockwise if the separation is set too narrow.

The separation is adjusted correctly when a slight resistance is felt on the document/BRE.

7. Pull knob **E** back when ready.
8. Remount feeders 2 and 3.

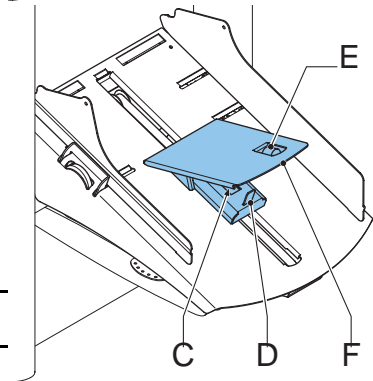

5.4.5 Feeding Documents

To feed documents:

1. Squeeze the two blue handles **C** and **D**.
2. Shift the feeding plate **F** to the rear position.

- Loosen the stack of documents and place them in the feeder.
BREs with flap down and leading (top side pointing to system).

The feeding plate assembly will be shifted up automatically (when the system starts processing) until documents/BREs are underneath the rubber paper pullers.

Note

When filling the Production Feeder, be sure that the document/BREs are positioned parallel in relation to the feed plate to ensure correct feeding.

5.5 High Capacity Feeder

This option can only be installed from factory. The High Capacity Feeder has a capacity for up to 725 sheets. The normal document feeder tray has a capacity of 325 sheets.

5.5.1 Installation of Feeder Tray

To install the feeder tray of the High Capacity Feeder:

- Pull down lever **A**.
- Hook in the feeder tray.
- Release lever **A**.

5.5.2 Adjusting the Side Guides

To adjust the side guides **B**:

- Loosen the knob **D** half a turn.
- Put a small stack of documents between the side guides.
- Rotate wheel **E**.

The space between the side guides and the documents should be such that the documents have just enough play to move freely.

- Re-tighten knob **D**.

5.5.3 Document Separation

The document separation is set automatically. There are no manual adjustments needed.

5.5.4 Filling the High Capacity Feeder

To fill the document feeder tray:

- Pull down lever **A**.
The feeder rollers **C** move up to filling level.
- Place a stack of documents between the side guides (max. 725 sheets, 80 g/m²).
Feed the documents (depending on the type of documents and the type of fold) as shown in 3.4.1 "Document Orientation" on page 14.
- Release lever **A**.

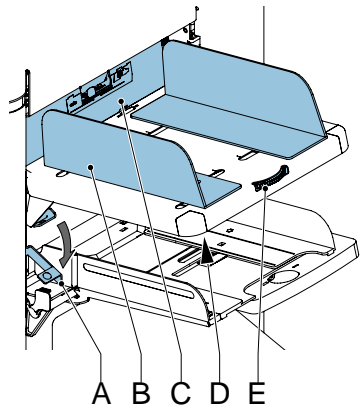

5.6 High Capacity Vertical Stacker (HCVS-1)

The High Capacity Vertical Stacker can be used to stack filled envelopes. The vertical stacker can store up to 500 filled envelopes. The vertical stacker can be equipped with Mail Piece Production Control (MPPC).

5.6.1 Adjusting the Side Guides

Adjust the side guides with wheel **A** so, that a margin of 3 to 5 mm is left between the envelopes and the side guides.

For small envelopes it can be necessary to remove the extensions **B** from the envelope support.

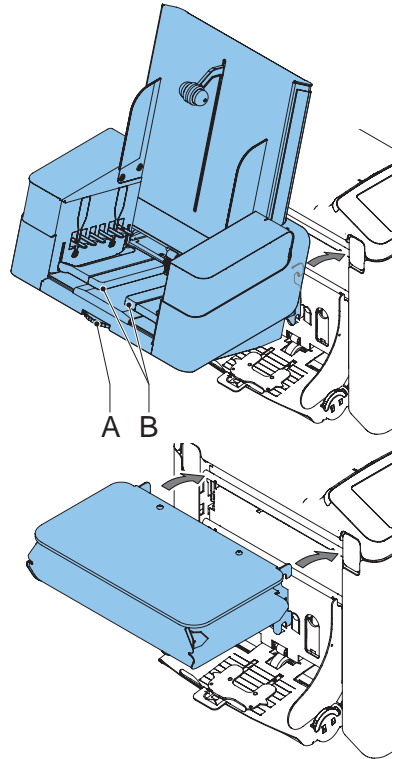

5.7 Side exit

The system can be equipped with a side exit and catch tray. The side exit can be fitted instead of the standard envelope receiving tray. The side exit allows a conveyor or a franking system to be fitted in line with the system.

The side exit can also be used with a catch tray to achieve vertical stacking. The catch tray is delivered with the side exit.

5.8 Mail Piece Production Control (MPPC) (Option¹)

The folding and inserting system can be equipped with Mail Piece Production Control. This option enables the system to verify the inserted documents or sets of documents with a database, which is generated when you print the documents. The system gives a warning when a mail piece is missing at the exit of the inserter.

Refer to the appendix "Mail Piece Production Control" for an extensive description of this option.

5.9 Mailing / Franking

If this system is connected to a mailing/franking system, this feature allows you to:

- Switch automatic mailing/franking on or off
- Remotely select a mailing/franking job
- Set the printing/franking value (option)
- Automatically set the printing/franking value using the inserter data

For programming this option refer to 4.2.7 "Mailing/Franking Settings (Option)" on page 27.

1. Ask your supplier if this option is available for your system.

6. OPERATOR MAINTENANCE

Warning

- Disconnect the mains power supply before performing any maintenance.



The user must not attempt to service the appliance beyond that described in this operator manual. All other servicing must be carried out by qualified service personnel only.

Please contact your authorized distributor.

Maintenance frequency	Maintenance
Daily	<ul style="list-style-type: none"> • Check the system functions. • Keep the system in proper condition by removing dust, paper remains, etc. • When dirty, clean the sealing table and rubber rollers with a slightly wetted cloth, soaked in warm water.
Weekly	<ul style="list-style-type: none"> • When dirty or saturated, clean the brushes of the envelope sealing. The system is delivered with an extra set of brushes. To always have one clean set available, it is recommended to soak one set in water and use the other set. Remove the brushes one by one by pulling them down from the brush holder. Replace the brushes and make sure that the studs on the brushes are fitted in the corresponding holes in the brush holder. • Check moistening cloth and replace if necessary. When dirty or saturated, clean the moistening cloth and the reservoir. • Clean feed and insert rollers as instructed by the service engineer.
When necessary	<ul style="list-style-type: none"> • When the touch screen warns about dusty sensors, the sensors on the envelope or document path must be cleaned. Use the bellows that is located behind the side cover. Place the bellows in the hole and firmly squeeze a few times to blow the dust from the sensor. Repeat this procedure for the hole to clean the flap sensor. If the exit sensors have to be cleaned, use a slightly wetted cotton swab: <ul style="list-style-type: none"> - Lower exit sensor: insert the wetted cotton swab into the hole and spin once. - Upper exit sensor: insert the wetted cotton swab into the hole for the upper sensor and spin once. <p>Note When finished cleaning the sensors always calibrate the sensors (see 2.4.6 "Test Menu" on page 11).</p>

7. FAULT FINDING

7.1 Error Messages

When an error occurs the touch screen shows a menu showing the following information:

- An indication of the area in which the error occurred
- An error description
- A suggested solution behind the pointing hand

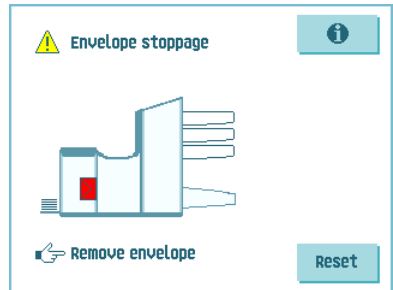

Press  to view more information about the error and about the possible actions to dfYj Ybh the error from recurring.

After solving the problem, press **Reset** to reset the error (the error menu will disappear).

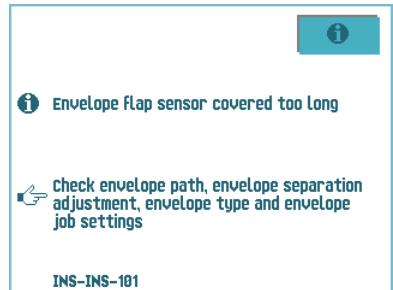

Special Errors

- Reading errors (when reading is enabled)
The document stops in the collating area. The operator must remove the document set and has to complete the set manually"
- Technical errors
The touch screen shows a message. The error cannot be solved by operating personnel and assistance of the service support is needed.

Warning Screen

When a cover is opened, the touch screen shows a warning screen with the message "Cover open" and a suggested solution "Close cover".

7.2 Clearing Jams

Jams can occur in the following areas:

- A Folder and feeder
- B Collating area
- C Envelope track and inserter area.

7.2.1 Folder or feeder

When a jam occurs in the folder or the feeder, remove the documents as follows:

1. Open the upper unit **A** by pulling up the handle.
2. Remove the documents from the folder or the feeder.
3. Close the upper unit **A**.
4. Press **Reset** to reset the error and restart the job.

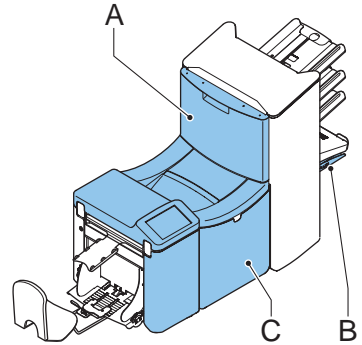

7.2.2 Collating Area

When a jam occurs in the collating area, remove the documents from the collating area as follows:

1. Move the collator plate **B** down.
2. Remove the documents.
3. Move the collator plate **B** up in position.
4. Press **Reset** to reset the error and restart the job.

7.2.3 Lower Envelope Track

When a jam occurs in the lower envelope track, remove the envelopes as follows:

1. Open the side cover **C**.
2. Pull down the blue handle **D** and remove the envelope(s) from the lower envelope track.
3. Close the side cover.
4. Press **Reset** to reset the error and restart the job.

If necessary, the envelopes and documents can be transported manually:

- Turn the blue knob **E** clockwise to transport an empty envelope to the insert position.
- Turn the blue knob **F** clockwise to transport the filled envelopes to the exit.

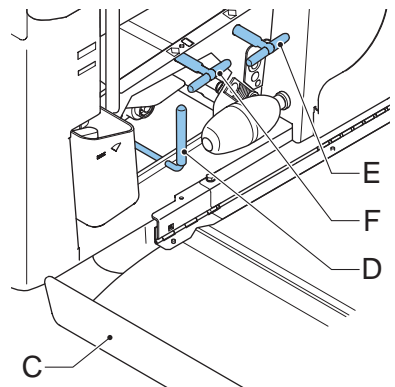

7.3 Operator Troubleshooting

To solve problems:

1. Write down the error.
2. Consult the troubleshooting table to solve the problem.
3. Switch the inserter off and on again, to verify system operation.
4. When the error still occurs contact your service organization.

Note

When contacting the service organization, you will also be asked for the last error message and the software version of the installed software. To determine the software version, refer to 2.4.5 "Supervisor Menu" on page 10.

Symptom	Possible cause	Remedy	Reference
The system cannot be started after switching on.	System not connected to mains.	Connect the system to the mains.	-
	Fuse is blown.	Replace fuse below power switch.	-
	A cover is opened.	Close the covers.	-
System stops with envelope at insert position (flap not open).	Envelopes stacked reversed in the hopper.	Check envelope feed adjustments. Place envelopes correctly in hopper.	"Loading Envelopes" on page 16
	Envelope flap sticks.	Store envelopes according to specifications.	"Envelope Settings" on page 21
	Wrong envelope type used (not according to specifications or job settings).	Change envelopes according to specifications.	"Envelope Settings" on page 21
Envelopes are double fed.	Envelope separation not correctly set.	Adjust envelope separation.	"Loading Envelopes" on page 16
	Envelopes not placed properly in the hopper.	Check and replace if needed.	"Loading Envelopes" on page 16
Envelope stops skewed.	Side guides of the envelope hopper are set too wide.	Check side guides and adjust if needed.	"Loading Envelopes" on page 16
Envelopes are fed irregularly.	Hopper almost empty.	Refill hopper.	"Loading Envelopes" on page 16
	Separation set too narrow.	Adjust envelope separation.	"Loading Envelopes" on page 16
	Side guides set too narrow.	Check side guides and adjust if needed.	"Loading Envelopes" on page 16
	Envelope support not positioned correctly.	Reposition the envelope support.	"Loading Envelopes" on page 16

Symptom	Possible cause	Remedy	Reference
Flap is wrinkled and sometimes not opened.	Envelope not within specifications.	Check specifications and change envelopes if needed.	"Envelope and Insert Specifications" on page 51
	Flap sticks.	Store envelopes according to specifications.	"Envelope and Insert Specifications" on page 51
	Flap curled.	Envelopes stored or manufactured improperly.	"Envelope and Insert Specifications" on page 51
	Separation set too narrow.	Adjust envelope separation.	"Loading Envelopes" on page 16
Fingers are placed on top of the envelope.	Fingers adjusted too deep into the envelope.	Check fingers position, adjust if needed.	"Envelope Insert Fingers" on page 49
	Envelope stops too early.	Check envelope stop position, adjust if needed.	"Insert Position" on page 49
System stops while inserting (stoppage at the inserting point).	Fingers not correctly adjusted.	Check fingers position, adjust if needed.	"Envelope Insert Fingers" on page 49
	Inserted document too long for used envelope.	Check fold settings.	"Fold Settings" on page 24
	Envelope throat incorrect.	Check envelope specifications.	"Envelope and Insert Specifications" on page 51
	Envelope glued inside.	Eliminate faulty envelopes.	-
	Window not glued properly.	Eliminate faulty envelopes.	-

Symptom	Possible cause	Remedy	Reference
Flap not sufficiently moistened.	Water level low.	Check water level, refill if needed.	"Filling the Sealing Liquid Reservoir" on page 17
	Brushes dry.	Check brushes, replace if needed by the extra soaked set.	"Operator Maintenance" on page 43
	Brushes dirty.	Check brushes, clean if needed.	"Operator Maintenance" on page 43
	Moistening felt dry.	Check the moistening felt, refill water tray if needed.	"Filling the Sealing Liquid Reservoir" on page 17
	Moistening felt dirty.	Check the moistening felt, clean if needed.	"Operator Maintenance" on page 43
	Brushes worn out.	Replace brushes.	"Operator Maintenance" on page 43
	Moistening felt worn out.	Replace moistening felt.	"Operator Maintenance" on page 43
Envelope not always ejected from sealer.	Inserted document too big.	Check fold settings, adjust if needed.	"Fold Settings" on page 24
	Document not inserted deep enough.	Check adjustment of envelope stop position and fingers.	"Insert Position" on page 49
	Sealing area dirty.	Clean sealing area.	"Operator Maintenance" on page 43
No document fed.	Feeder empty.	Refill feeder.	"Filling the Document Feeder Tray" on page 16
	Separation set too wide / too tight.	Adjust the separation.	"Document Separation" on page 15
	Side guides set too narrow.	Adjust the side guides.	"Adjusting Side Guides" on page 14
Skewed documents fed.	Side guides set too wide.	Adjust side guides.	"Adjusting Side Guides" on page 14
Double documents fed.	Separation set too wide.	Adjust the separation.	"Document Separation" on page 15
Document set not correctly inserted.	Insert position not correct.	Check insert position.	"Insert Position" on page 49
	Insert fingers not correctly positioned.	Check insert finger position.	"Envelope Insert Fingers" on page 49
Address not readable from window	Address position not correctly defined.	Check address position.	"Address Position" on page 49

7.3.1 Insert Position

To make a good insert of the document set into the envelope, the envelope should be positioned correctly.

The document set is inserted correctly if the flap folding line of the envelope is positioned underneath the green roller **B**.

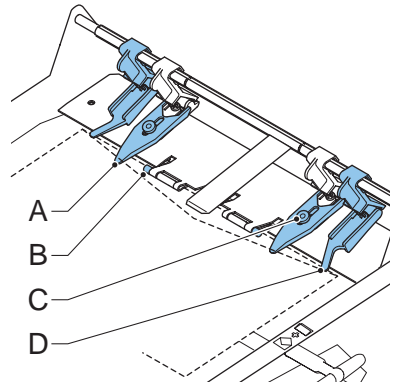

To verify the insert position:

1. Choose a job and press the **1x** button.
2. Press **No** until the question about envelope position appears.
3. Press **No** again and follow the instructions on screen.

7.3.2 Envelope Insert Fingers

To make a good insert of the document set into the envelope, the insert fingers **A** should be about 5 mm (0.2 inch) inside the envelope.

The outer fingers **D** should be about 5 to 10 mm (0.2 to 0.4 inch) from the edges of the envelope.

To verify that the position of the fingers is correct:

1. Choose a job and press the **1x** button.
2. Follow the steps in the troubleshooting wizard.

7.3.3 Address Position

The address on the document set should be positioned in a way that you can read it from the envelope window. If it is not readable, adjust the address position as follows:

1. Choose a job and press the **1x** button.
2. Press **No** if asked if the mail set is correct.
3. Press **Yes** if asked if the documents are inserted correctly.
4. Press **No** if asked if the address is readable.
5. Follow the steps in the troubleshooting wizard.

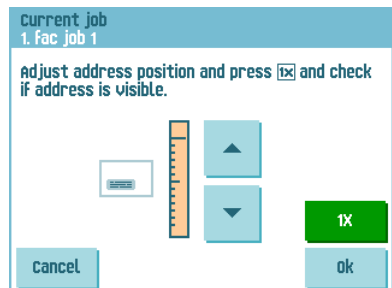
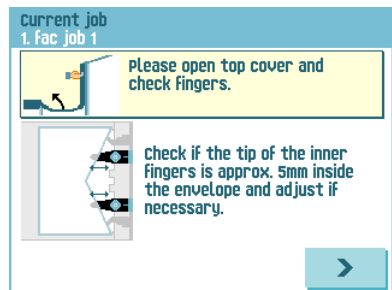
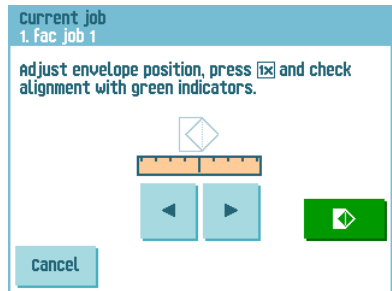

8. SPECIFICATIONS

8.1 Technical Specifications

Type:	Fold and insert system for medium office use
Theoretical max. speed	3600 inserts per hour, depending on application
Power consumption:	100 VAC / 50 Hz / 5.0 Amps (voltage tolerance: +6%/-10%) 115 VAC / 60 Hz / 5.0 Amps (voltage tolerance: +6%/-10%) 230 VAC / 50 Hz / 2.5 Amps (voltage tolerance: +10%/-10%)
Fuse	100/115 VAC: T 5.0 A, 125 V. Time lag, 5.0 Amps rated current, 125 V 230 VAC: T 2,5 A H, 250 V. Time lag, 2.5 Amps rated current, high breaking capacity, 250V
Approvals:	EMC Certificate conform EMC-Directive FCC Certificate conform 47CFR, part 15 CB Certificate conform IEC 60950-1 UL Listed I.T.E. (Information Technology Equipment), conform UL-IEC 60950-1, file E153801 Conform NEN-EN-IEC 60950-1 and derivatives

8.2 Configuration Dimensions

Height	720 mm (28.3 inch) 800 mm (31.5 inch) including High Capacity Vertical Stacker
Width	455 mm (17.9 inch) including side exit catch tray
Length	770 mm (30.3 inch) on covers 1120 mm (44.1 inch) including hopper and feeder trays 1200 mm (47.2 inch) including side exit 1270 - 1360 mm (50.0 - 53.5 inch) including catch tray 1360 mm (53.5 inch) including High Capacity Vertical Stacker
Weight	73 kg (160.9 lbs)

8.3 Other Specifications

Noise level	<66 dBA (according to ISO 11202)
Operating temperature	10°C - 40°C (50°F-104°F)
Humidity	30%-80%

8.4 Document Specifications

Paper quality	minimum 60 g/m ² (15 lb bond) maximum 250 g/m ² (62.5 lb bond), when folded max. 170 g/m ² (42.5 lb bond) Booklets up to approximately 1 mm (0.04 inch) thickness, depending on stiffness
Paper size	Minimum width: 130 mm (5.1") Maximum width: 236 mm (9.3"), when folded 230 mm (9.1") Minimum length: 90 mm (3.5") Maximum length: 356 mm (14.0")
Folding capacity	Single fold - 10 sheets (max. 80 g/m ²) Letter fold / Z-fold - 8 sheets (max. 80 g/m ²) Double parallel fold - 4 sheets (max. 80 g/m ²)
Envelope sizes	Standard BRE (Business Reply Envelopes)
Envelope quality	minimum 80 g/m ² (20 lb bond) maximum 120 g/m ² (30 lb bond)

8.5 Envelope and Insert Specifications

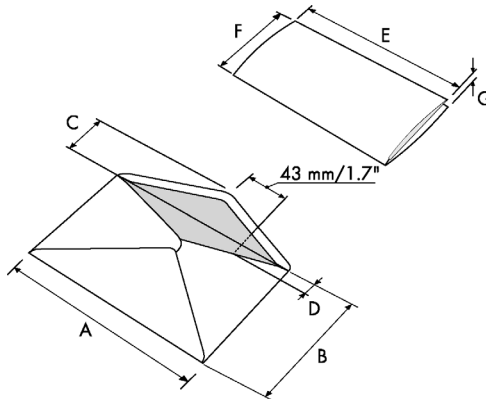

		A	B	C	D	E	F	G
Minimum size	mm	160	90	32	10	130	84	60 g/m ²
	inches	6.3	3.5	1.25	0.4	5.1	3.3	60 g/m ²
Maximum size	mm	248	162	B-32	35	A-12**	B-6	2.5*
	inches	9.7	6.38	B-1.25	1.4	A-0.47**	B-0.2	0.1
* Booklets up to approximately 1 mm (0.04 inch) thickness, depending on stiffness								
** When insert is more than 1 mm (0.04 inch): A-15 mm / A-0.6 inch								

Remarks:

- Maximum insert specifications are based on single sheets. When multiples are handled, more room inside the envelope is needed depending on the application.
- The specification of the paper handling equipment is often wider than that of the envelopes and documents handled. The condition of material handled will limit the specified environmental conditions.
- We recommend that materials to be handled are stored at a temperature of 20°C (68°F) with a relative humidity factor of 50%. If difference in temperature occurs between store room and mailing area, the material has to be stored near the system at least 24 hours before use.
- Self-copying paper may cause rubber parts to wear quicker. The rubber used in this system has the best resistance to Wiggins Teape material.

8.6 Specifications High Capacity Vertical Stacker

Model	HCVS-1
Type	high capacity vertical stacker Suitable for all kinds of mail sets that consist of at least one 80 grams envelope and one folded document (80 gram).
Power consumption	low voltage supplied by the inserter system
Approvals	EMC Certificate conform EMC-Directive. FCC Certificate conform 47CFR, part 15. UL Listed I.T.E. (Information Technology Equipment), conform UL-IEC 60950-1, file: E153801. Conform NEN-EN-IEC 60950-1 and derivatives.
Height	550 mm(21.7 inch)
Width	440 mm (17.3 inch)
length	360 mm (14.2 inch)
Weight	12 kg (26.5 lbs)
Noise level	see 8.3 "Other Specifications" on page 50
Operating temperature	10°C - 40°C (50°F-104°F)
Humidity	30%-80%
Stacker capacity	325 envelopes, depending on application

8.7 Specifications Production Feeder

Model	MF-2
Type	high capacity feeder
Theoretical max. speed	see 8.1 "Technical Specifications" on page 50
Power consumption	low voltage supplied by the inserter system
Approvals	EMC Certificate conform EMC-Directive. FCC Certificate conform 47CFR, part 15. UL Listed I.T.E. (Information Technology Equipment), conform UL-IEC 60950-1, file: E153801. Conform NEN-EN-IEC 60950-1 and derivatives.
Height	210 mm (8.3 inch)
Width	285 mm (11.2 inch)
length	425 mm (16.7 inch)
Weight	5.05 kg (11.1 lbs)
Noise level	see 8.3 "Other Specifications" on page 50
Operating temperature	10°C - 40°C (50°F-104°F)
Humidity	30%-80%
Feeder tray capacity	1200 sheets 80 gr., max. length 156 mm (6.1 inch) 320x Business Reply Envelopes
Document / BRE insert specifications	see 8.4 "Document Specifications" on page 51 and 8.5 "Envelope and Insert Specifications" on page 51

9. TERMINOLOGY

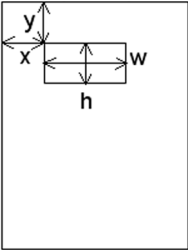
Term	Description
Address carrier	The address carrier is the document that carries the address of the person for who the mail set is meant. The address carrier can consist of one or more sheets, from which at least the first sheet must contain the address. The address must remain visible while enclosures are added and the document set is folded. The fold type and selected envelope must ensure that the address is visible behind the window in the envelope. For personalized mailings there is always an address carrier present as long as envelope printing is not supported. Normally there is one address carrier.
Address position	 <p>Position of the address on the address carrier, measured from the upper left corner. The address position consists of a horizontal x coordinate, a vertical y coordinate, a horizontal width w and a vertical height h.</p>
AutoGYh	The feature of an inserting system to automatically determine its job settings by measuring the sizes of documents and envelope. From all feeders that are loaded one sheet will be taken. Based on the maximum document length (which is also the length of the document set) and the length of the envelope the fold type is determined.
Autoa UhWcV	A job that is created with the AutoSet feature.
Barcode Reading (BCR)	Barcode Reading is intended for reading and interpreting printed barcodes. The codes give information to the inserting system about how to build-up and handle a set.
Business Reply Envelope (BRE)	Envelope included in outgoing mail sets for addressee response purposes.
C-fold	See Letter fold.
Daily Mail	Capability of an inserting system to manually insert mail sets one by one into the system, which are then inserted into an envelope. Optionally, depending on settings, additional enclosures can be added and the mail set can be folded. This function is intended for small amounts of mail that each can have a different build-up.
Document	A document is one of the components of a mail set. A document can consist of one or more sheets. Documents can be divided into address carriers and enclosures. For personalized mailings there is always one address carrier and an optional number of enclosures.
Document set	The document set is the physical collection of address carrier and enclosure(s) that is under production in the inserting system. The document set is completed during production and is to be inserted into the envelope. The number of enclosures can range from 0 to the limit opposed by the number of available feeders. Once the document set has been inserted into an envelope it is called mail set.

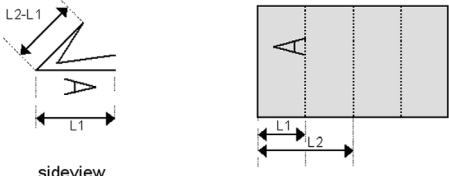
Term	Description
Double Feed Control (DFC)	<p>Double Feed Control is the sensor that measures the thickness of a sheet to check if the inserting system does not accidentally take more sheets than intended. DFC sensors exist on feeders (double sheet detection). Currently DFCs on Formax inserting systems perform relative measurements, which means that they need a cycle to 'learn' the thickness of a sheet.</p> <p>Also the length of the document is measured so partly overlapping sheets will be detected.</p>
Double parallel fold	<p>The double parallel fold is a type of fold where the document is first folded halfway and the resulting folded set is again folded halfway. This fold is illustrated in the picture below. The position of both folds is adjustable.</p>  <p style="text-align: center;">sideview</p>
Envelope	<p>The envelope is the packaging of a mail set. Window envelopes are envelopes that have a transparent section through which the address on the address carrier can be read. Besides the normal top closing window envelopes there are also bottom closing envelopes.</p>
Face down	<p>Situation in which the front of a sheet is facing downwards when placed in a document feeder.</p>
Face down leading	<p>Situation in which the front of a sheet is facing downwards and the top of the sheet is closest to the separation unit in a document feeder.</p>
Face down trailing	<p>Situation in which the front of a sheet is facing downwards and the bottom of the sheet is closest to the separation unit in a document feeder.</p>
Face up	<p>Situation in which the front of a sheet is facing upwards when placed in a document feeder.</p>
Face up leading	<p>Situation in which the front of a sheet is facing upwards and the top of the sheet is closest to the separation unit in a document feeder.</p>
Face up trailing	<p>Situation in which the front of a sheet is facing upwards and the bottom of the sheet is closest to the separation unit in a document feeder.</p>
Feeder	<p>A feeder is a module for the input of documents to the inserting system. The feeder separates documents sheet by sheet from the stack of documents in the feeder tray.</p>
Feeder linking	<p>The ability to load two feeders with the same document type where the inserting system automatically switches to a second feeder when the first feeder is empty and vice versa. In the mean time the first feeder can be refilled, so the inserting system can keep running without having to stop for refilling the feeders.</p>
Feeder tray	<p>Part of the feeder that contains the stack of documents.</p>

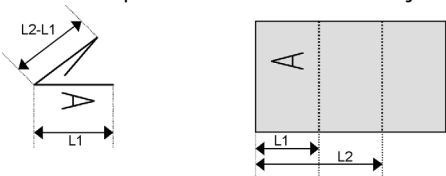
Term	Description
Flexcode OMR	An OMR code for which the meaning of the OMR marks can be programmed in a dedicated way for a specific customer. This is normally used to support the OMR codes from other suppliers.
High Capacity Feeder	Feeder that has a capacity for 725 sheets.
High Capacity Vertical Stacker	Optional stacker that is mounted on the exit of the system, to stack filled envelopes.
Insert	<ul style="list-style-type: none"> • An insert is the action of inserting a document set into an envelope. •5n insert is also a short, not to be folded document, usually an enclosure.
Inserter	An inserter is the module where the document set is inserted into the envelope, the envelope is closed and if necessary sealed.
Inserting system	The system of all the modules that cooperate to perform the inserting function (accumulate document set, fold and insert) and have a single point of control.
Insert # Frank (mailing system)	Interface for the franking system.
Job	<p>A job is an actually produced collection of mail sets based on a certain job definition at a certain point in time for a specific purpose. It consists of:</p> <ul style="list-style-type: none"> • The job definition used for the production • Information about the batch size
Job counter	The counter that registers the number of mail sets that is produced as part of a specific job.
Letter fold	<p>Fold type in which a document set is folded twice in which the folded flaps are on top of each other. This fold is illustrated in the picture below. The position of both folds is adjustable.</p>  <p>sideview Synonym: C-fold.</p>
Linking	See feeder linking.
Production Feeder	Feeder with high capacity feeder tray
Multifeed	The feature of an inserting system in which more than one sheet is taken from a feeder.
OMR	Optical Mark Recognition
OMR code definition	Standard 1-track OMR code definition. Specifies the amount of reading marks used and the functionality linked to each of them (how each should be interpreted).
Operator	The person operating an inserting system.

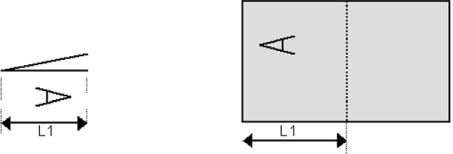
Term	Description
Optical Mark Recognition (OMR)	Optical Mark Recognition is intended for reading and interpreting printed codes. These codes are one or more black marks which are read from a document. These marks give information to the inserting system about how to build-up and handle a set.
Reading error	Condition in which the system could not reliably read or interpret the OMR reading marks or barcode from a sheet.
Reading marks	Marks added to documents containing finishing instructions that can be identified by an reading head and interpreted according to the used OMR code definition.
Remote diagnostics	The feature that makes it is possible to analyze a problem on an inserting system from a remote location.
Service engineer	Technical engineer whose task it is to resolve problems with systems in the field. Besides dealing with problems, service engineers are also responsible for preventive maintenance.
Single fold	<p>A single fold implies the document set is folded once. The fold position is adjustable. This fold is illustrated in the picture below:</p>  <p>sideview</p>
Stacker	Used as storage for filled envelopes.
Stop counter	Counter which sets the amount of envelopes to be filled. After filling this amount of envelopes the system will stop.
Supervisor	Person who is responsible for the technical state of the system. Normally a supervisor has access to programming functions, which are restricted for standard users.
Test run	<p>A test run is intended to validate the settings of the inserting system:</p> <ul style="list-style-type: none"> • Inspect and adjust the stop position of the envelope. • Check the fold settings for one set. • Check whether the address is correctly positioned behind the envelope window.

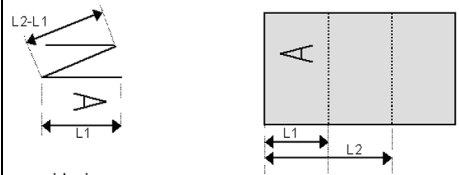
Term	Description
Tray	Contains a stack of paper for a printer or inserter. This paper is supplied to the system for further processing.
Vertical transport	The vertical transport section between feeders and collator.
Z-fold	<p>A Z-fold means that a document is folded twice in such a way that each folded flap is on a different side of the folded document, resulting in a Z-shape. This fold is illustrated in the picture below. The position of both folds is adjustable.</p>  <p>sideview</p> <p>Synonyms: zigzag fold</p>

This is a class A product. In a domestic environment this product may cause radio interference in which case the user may be required to take adequate measures.

Note: this equipment has been tested and found to comply with the limits for class A digital device, pursuant to Part 15 of the FCC Rules. These limits are designed to provide reasonable protection against harmful interference when the equipment is operated in a commercial environment. This equipment generates, uses, and can radiate radio frequency energy and, if not installed and used in accordance with this instruction manual, may cause harmful interference to radio communications. Operation of this equipment in a residential area is likely to cause harmful interference in which case the user will be required to correct the interference at his own expense.

Index

A

address carrier 54
address position 49, 54
automatic job 18, 54

B

Barcode Reading
 see BCR
BCR 54
 adjustments 29
 codes 31
 document orientation 31
 settings 25
 test 11
bellows 7
brush replacement 43
business reply envelope 54
button 8

C

calibrate photocell 11
catch tray 7, 42
cleaning 43
collating area 6
collator arm 7
configuration 38
configuration dimensions 50
connection 37
connection history 37
contrast 10
control panel 7, 8
counter 8
cover 7

D

daily mail 54
daily mail handle 19
daily mail settings 23
date online services 38
DFC
 settings 26
diagnostics 11
dial tone detection 38
display
 see touch screen
display settings 10
document 54
 feeder tray 7

 height 23
 orientation 31
 separation 15
 settings 22
 specifications 51
document orientation
 normal 31
 reading 31
document set 54
document stoppage
 see stoppage
double feed control 6, 55
double feed control settings 26
double feeding 46, 48
double parallel fold 55

E

envelope 55
 feed 16
 insert position 49
 load 16
 no envelope mode 22
 quality 51
 sealing 22
 separation 16
 settings 21
 size 21, 22, 51
 slide 7
 specifications 51
 support 7, 17
envelope feeder
 side guides 16
error messages 44
errors
 reading errors 44
 technical errors 44

F

face down 55
face down leading 55
face down trailing 55
face up 55
face up leading 55
face up trailing 55
feed
 document 16
 envelope 16
feeder 55
 automatic 6, 15
 install 12
 link 23

- load 16
- remove 14
- side guides 14
 - special 6, 15
- feeder linking 55
- feeder tray 55
 - install 12
- fill sealing liquid reservoir 17
- finger position 49
- flex certificate 10
- flex code 34
- fold
 - C 54
 - double parallel 24
 - letter 24
 - none 24
 - single 24
 - zig-zag 24
- fold settings 24
- Folder 6
- franking
 - settings 27
- franking system 42
- fuse 46

H

- High Capacity Feeder 41, 56
- High Capacity Vertical Stacker 42, 56
- home menu 8

I

- insert 56
- insert position 49
- insert specifications 51
- insert'n Frank 42
- inserter 56
- installation 12

J

- job 56
 - copy 28
 - counter 56
 - create 20
 - delete 28
 - description 8
 - edit 27
 - information 8
 - job menu 11
 - name 26
 - new 20
 - select 17

- settings 21
- start 17
- job list 8

L

- letter fold 56
- loading envelopes 16

M

- Mail Piece Production Control 21
- main menu 10
- maintenance 43
- manual document feeding 23
- maxiFeeder™ 39, 56
 - document separation 40
 - feed documents 40
 - installation 39
 - side guides 40
- menu button 8
- menu, main 10
- message 37
- modem 7
- modem volume 39
- MPPC 21
- multifeed 56

N

- noise level 50
- number of sheets 22

O

- OMR 56
 - 1-track 25, 29
 - adjustments 29
 - align heads 29
 - codes 31
 - description 29
 - document orientation 31
 - settings 25
 - test 11
- online services 11, 36, 42
- operating controls 7
- operating instructions 12
- Optical Mark Recognition
 - see OMR
- option
 - activate 29
 - information 10
 - license code 29
- overview 5

P

- paper quality 51
- paper size 51
- photocell calibration 11
- power consumption 50
- power switch 7

R

- reading head position 29
- reading settings 25
- reservoir
 - fill 17
- RS232 connector 7
- run a job 17

S

- safety 2
- seal envelope 22
- sealing liquid reservoir 7
- select a job 17
- sensor dusty 43
- side cover 7
- single fold 57
- slide 7
- software description 8
- software version 10
- speed 50
- stacker 42, 57
- start button 8
- starting the job 17
- stop button 8
- stop counter 9, 57
- stop the system 19
- stoppage
 - collating area 45
 - Feeder 45
 - inserting area 45, 47
 - lower envelope track 45
 - Folder 45
- supervisor menu 10
- system ID 10
- system info 10

T

- technical specifications
 - high capacity vertical stacker 52
 - inserter 50
 - maxiFeeder™ 53
- telephone number 38
- test menu 11

- test run 57
- touch screen 8
 - contrast 10
 - settings 10
- tray 58
- troubleshooting 46

U

- USB 7

V

- vertical stacker 42, 56
- volume acoustic signals 10
- volume modem 39

Z

- Z-fold 58