

# FORMAX<sup>®</sup>

---

FD 210M  
Manual Paper Creaser



## SPECIFICATIONS

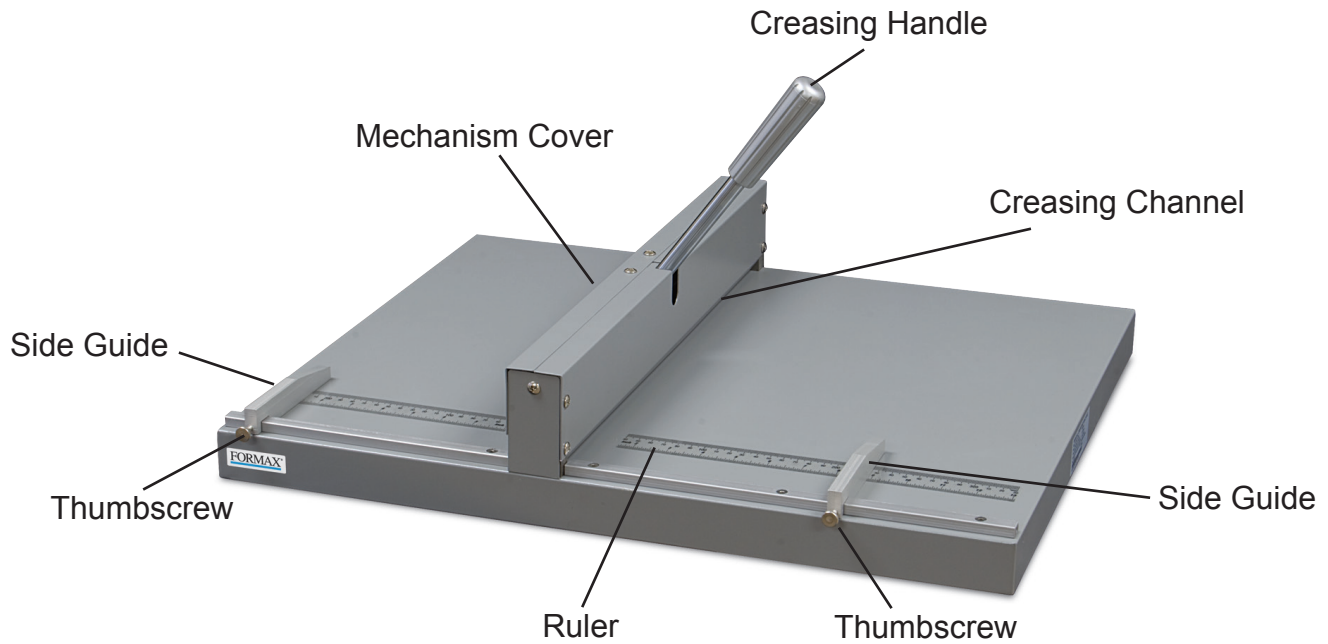

### **FUNCTION:**

The Formax FD 210M Manual Paper Creaser is designed to prevent cracking in toner-based digital printouts. Creasing sheets prior to folding ensures a clean, professional finish and makes it easier for folding devices to fold with accuracy.

Maximum paper width:	Up to 18" (460mm)
Maximum paper thickness:	< .014" (0.36mm)
Width of crease:	.05" (1.3mm)
Depth of crease:	.015" (.4mm)
Dimensions:	23.6" W x 19.29" D x 5" H (600 x 490 x 130mm)
Weight:	21.6 lbs (9.8kg)

## INSTALLATION AND SETUP

Check package for shipping damage. If there is shipping damage, do not discard the box.

Remove creaser from box and set on a level surface.

## **OPERATION**

1. Loosen thumbscrews on each side guide.
2. Slide side guides to correct location based on desired placement of crease.
3. Tighten thumbscrews.
4. Load paper by sliding through creasing channel under mechanism cover.
5. Once the paper is aligned between the side guides, grasp creasing handle and push downward, then release. Handle will return to upper position. NOTE: Do not push too hard. Excessive force is not required to create the crease, and may damage creasing mechanism.

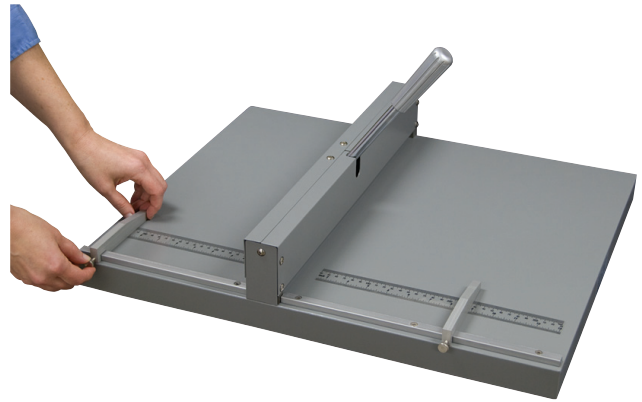

## **TWO-PART CREASING (BOOK SPINE CREASING):**

1. Measure sheet to be creased.
2. Move right side guide to correct location and tighten thumbscrew.
3. Align page to right side guide and press down handle to crease.
4. For second crease, move left side guide to correct location and tighten thumbscrew.
5. Align page to left side guide and press down handle to crease.

## **SAFETY GUIDELINES**

To avoid injury, do not place fingers into the creasing channel.

To avoid damage to the unit, do not place any objects other than paper into the creasing channel.