

FORMAX[®]

FD 215S
Semi-Automatic Paper Creaser

SPECIFICATIONS

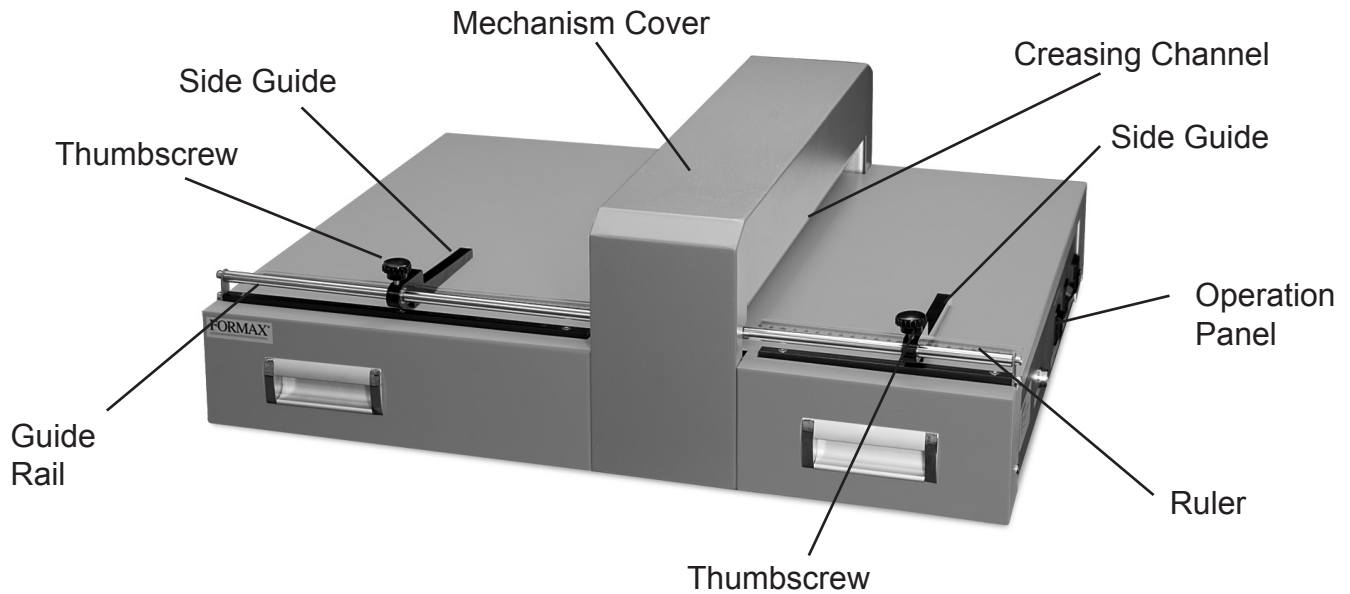

FUNCTION:

The Formax FD 215S Semi-Automatic Paper Creaser is designed to prevent cracking in toner-based digital printouts. Creasing sheets prior to folding ensures a clean, professional finish and makes it easier for folding devices to fold with accuracy.

Maximum paper width:	Up to 18" (460mm)
Maximum paper thickness:	< .018" (0.45mm)
Width of crease:	.062" (1.6mm)
Depth of crease:	.019" (.5mm)
Dimensions:	27.95" W x 21.25" D x 9" H (710 x 540 x 245mm)
Weight:	83 lbs (37.6kg)
Power:	110V AC, 60Hz, 120 watt

UNPACKING

Check package for shipping damage. If there is shipping damage, do not discard the box.

When choosing a location for the creaser, avoid the following: direct sunlight, areas of high temperature or humidity, areas without proper ventilation, or surfaces that are unstable.

Open the box, and pull the bands to remove the machine. Remove all protective packaging.

SAFETY NOTES

- * To avoid personal injury and/or damage to the machine, DO NOT place hands, fingers or any objects other than the paper to be creased inside the creasing channel
- * Keep any loose items including ties, jewelry or long hair away from the creasing channel, to avoid injury.
- * Children should not be allowed to operate the machine.
- * In the event the creaser needs to be repaired, turn off and unplug the machine. Contact your Formax Dealer for repair.

SETUP

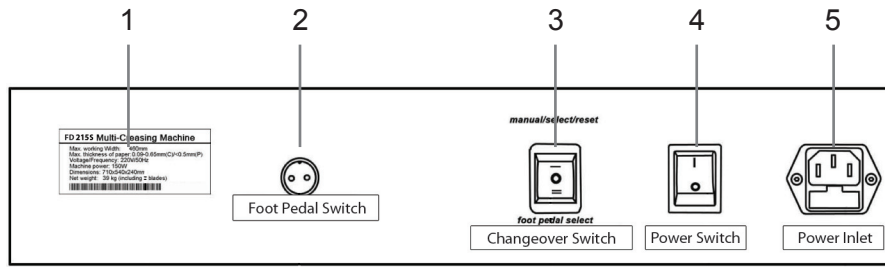

1	Machine Data Panel
2	Foot Pedal Switch Jack
3	Operation Mode Changeover Switch
4	Power Switch with Light
5	Power Inlet with Fuse

Remove the foot-control pedal from the box and attach it to the foot pedal switch on the Operation Panel. Be sure to align the pins correctly to avoid damage. Place the foot pedal on the floor.

Remove the power cord from the box and plug into the Power Inlet on the Operation Panel. Be sure the voltage from the wall outlet matches the voltage of the creaser.

OPERATION

1. Plug in and turn on the creaser. Be sure the red power indicator light is on.
2. Using the Changeover Switch (Fig. 1), choose the operating mode:
 - 2a. With switch in upper position (-), the creaser is in Manual Mode. The creaser will crease one time, with a single touch of the switch, and will automatically return to the center position (0).
 - 2b. With the switch in the center position (0), the machine is in standby but not operating.
 - 2c. With the switch in the lower position (=), the creaser is in Semi-Automatic Mode. After inserting the paper, the machine will crease one time after the foot pedal is pressed, then will return to standby mode.

It is suggested to leave the switch at (=) for Semi-Automatic Mode.

Manual Mode

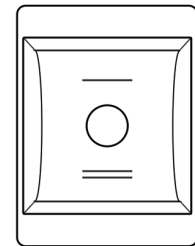

Semi-Automatic Mode

Fig. 1

3. Loosen thumbscrews on each side guide (Fig. 2).
4. Slide side guides to correct location based on desired placement of crease. When moving the side guides, lift gently while sliding to avoid damage to the guide rail.
5. Tighten thumbscrews.



Fig. 2

6. Load paper by sliding through creasing channel under mechanism cover (Fig. 3).



Fig. 3

7. Once the paper is aligned between the side guides, crease by using manual switch (Fig. 4) or foot pedal (Fig. 5). See Step 2 for explanation of modes.



Fig. 4



Fig. 5

8. Once the paper is creased, remove it from the creaser (Fig. 6).



Fig. 6

TWO-PART CREASING (BOOK SPINE CREASING)

1. Measure sheet to be creased.
2. Move right side guide to correct location and tighten thumbscrew.
3. Load sheet and align with right side guide. Engage creaser with foot pedal or manual control button. Remove sheet.
4. For second crease, move left side guide to correct location and tighten thumbscrew.
5. Load sheet and align with left side guide. Engage creaser with foot pedal or manual control button. Remove sheet.

MAINTENANCE

- * If the creaser will not be used for an extended period of time, turn off the power and unplug for safety.
- * After each use, turn off the creaser and clean the surface with a dry cloth.
- * To provide smooth operation, periodically apply a couple of drops of lubricating oil to the two mandrils and axle-tree connecting position.

