

FORMAX[®]

Shredder

FD 8902CC Cross-Cut

OPERATOR/
MAINTENANCE MANUAL
SECOND EDITION

Machine Specs	
Model: FD 8902CC	Serial #: _____
Motor	7.5KW (10HP)
Power	220V / 60Hz / 3-Phase
Sheet Capacity	Up to 650 Sheets
Throat Width	21"
Weight	1,984 lbs.

The machine number is specified on the nameplate on the shredder, shown above. Guarantee claims and inquiries cannot be processed if you do not quote the machine number.

Enter this number and the other data into the relevant fields of the nameplate shown here immediately after receipt of the shredder.

TABLE OF CONTENTS

TOPIC	PAGE
Safety Precautions	1-2
Checking Safety Devices	3
Overview	4
Machine Characteristics	5
Cutting Data, Speed, Dimensions, Weight	5
Motor Specifications, Power Requirements	5
Installation	5
Installation: Space Requirements	6
Start-up: Main Switch and Control Panel	7
Operation, Oiling, Overloading	8
Emptying Waste Bin	9
Maintenance: Removing Side Covers	9
Maintenance: Conveyor Belt Maintenance	9-10
Maintenance: Lubricating Shredder Mechanisms	11
Maintenance: Exterior Cleaning	11
Parts Lists	12-19

Safety Precautions

“Work safety” symbol



This symbol marks all work safety notes in this manual which can endanger the health or life of operators. Please pay attention to this symbol and exercise particular care in such cases. Please also forward all work safety notes to other users. Apart from the instructions in this manual, you should also follow generally applicable safety and accident prevention guidelines.

“Attention” notes



This icon marks information in this manual which requires particular attention including guidelines, regulations, instructions and correct working procedures intended to prevent damage to the machine and/or other equipment.

Notes on work safety

The FD 8902CC shredder has been inspected for safety. However, improper operation and misuse risk the following:

- the health or life of the operator
- the machine and other valuable equipment
- the efficient operation of the shredder.

The FD 8902CC employs state-of-the-art technology and is safe to operate. However, this machine can become hazardous if used incorrectly, by untrained staff or for purposes other than those for which it is designed.

- Material with a tendency to curl, e.g. tapes, cords, etc. should not be processed.
- Keep long hair, loose clothes, ties, scarves, etc. away from paper feed opening.
- Only one person should operate the shredder at a time.
- Always follow local safety and accident prevention regulations when operating the shredder.
- No pedestals or other raised surfaces may be placed in the vicinity of the machine if they alter the safety clearances.
- All connecting cables must be laid in such a way that they cannot be tripped over.
- Mechanical wearing parts must be inspected once a year.

The FD 8902CC shredder is intended for shredding paper, cardboard, archive files, tapes, ribbons, CDs and magnetic disks. The hardened, solid-steel cutting rollers are unaffected by loose-leaf binders, paper clips and staples contained in these materials.

Any other use beyond the scope described here is regarded as **not being in accordance with the instructions**. The manufacturer will not be held liable for damage resulting from incorrect use; the user alone is responsible.

Users must also follow the assembly, dismantling, re-assembly, operation and maintenance procedures specified by the manufacturer. The operation, maintenance and repair of the machine must be performed only by trained personnel who are aware of the potential dangers.

The relevant accident prevention regulations as well as other generally recognized rules concerning safety engineering and occupational safety must be observed.

- Each person responsible for assembling, dismantling and reassembling and maintenance (inspection, servicing, repair) of the shredder must have read and fully understood the entire operating manual, in particular the "Safety" section.
- The shredder may only be operated, serviced and repaired by authorized, trained personnel.
- The shut-down procedures specified in this manual must be followed during all assembly, dismantling and re-assembling, cleaning, and maintenance work. This type of work must be performed only when the machine is idle.
- The drive of the FD 8902CC must be secured against unintentional switching-on before performing work on the machine. Set the main switch to "Off" and unplug machine from wall outlet.
- After repair, check all protective devices to be sure they have been re-installed before operation.
- Do not perform any work which may impair your safety while operating the machine.
- Immediately report any changes which impair your safety to the person responsible. Shut the machine down until such damage has been resolved.
- Before operating the shredder, ensure that it is in perfect working condition.
- Ensure that the workplace around the FD 8902CC is always clean and safe.
- The user must not make any conversions or changes on his own initiative which impair the safety of the FD 8902CC. Protective devices must not be removed or rendered inoperative.
- All work which is not directly connected to the normal operation of the machine must always be performed when the machine is idle.
- Doors and flaps must not be opened until the machine is motionless. Observe safety labels!
- Test the safety features after installing or repairing electrical components.

Checking the safety devices

Check the safety devices:

- at the start of each work shift (when operation is sporadic)
- at least once a week in continuous operation
- after each maintenance or repair

Check the safety devices for:

- specified condition
- specified location
- safe attachment
- specified function

Correct defects before you operate the shredder.

1. Immediately shut down the shredder if defects occur during operation and make sure the defects are corrected.
2. Do not modify or remove protective devices. Do not switch off protective devices. For safety reasons, modifications of the machine are not allowed.



Danger: Defective safety devices can cause serious accidents. If safety devices are not working properly, the shredder should immediately be put out of operation.

Never reach into the cutting system while it is operating; you risk serious injury!

Only when all safety devices are operating correctly can the shredder be used again.

Operate the shredder only when these devices have been checked and are in order.

1. Check the **Safety Bar** push switch (A) in front of the feeding table:

The shredder must switch off immediately when you press the **Safety Bar** and the Emergency Stop Light (B) must go on.

2. Check the **Emergency Stop Button** (B) on the left of the control panel:

The shredder must switch off immediately when the button is pushed, and the Emergency Stop Light must go on.

3. Check the **Safety Switch** inside the Cutting Block Access Door at the top of the shredder (C). Press the door handle release. Handle will rotate up. Pull up on handle.

The shredder must switch off immediately when the door is opened, and the Emergency Stop Light must go on.

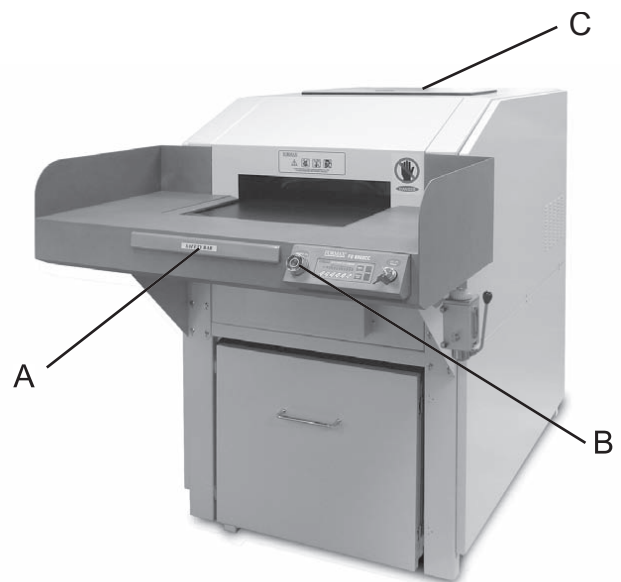

General Overview

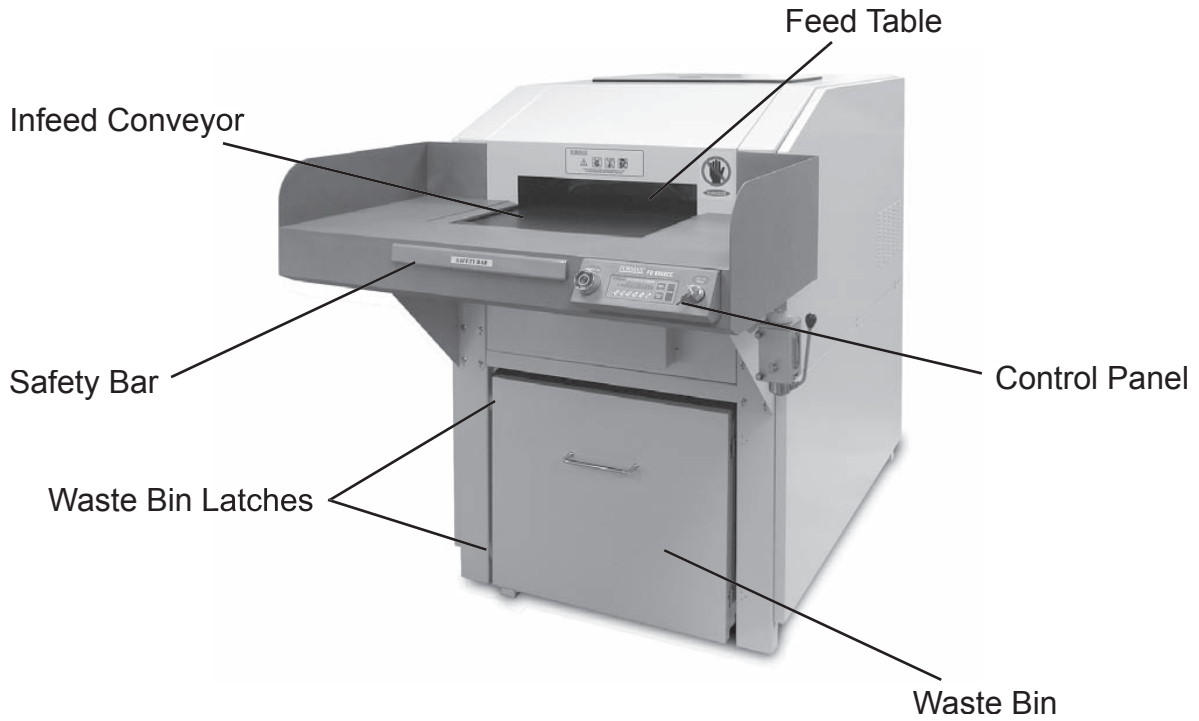

Front View with Waste Bin



**Left Side View with
Electricity Control Box Access Door**

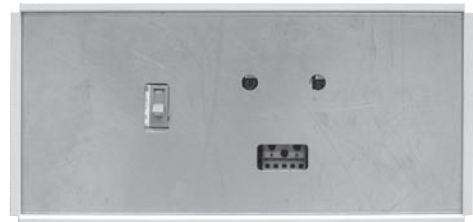

Breaker Panel



Control Panel

Machine characteristics

Machine designation: FD 8902CC

Machine type: conveyor-belt paper shredder

Total machine weight: 1,984 lbs.

Technical equipment: large feeding table, infeed conveyor belt

Cutting Data, Speed, Dimensions, Weight

FD 8902CC

Cutting Style:	Cross Cut
Shred Size:	5/16" x 1-1/2" - 3"
Sheet Capacity:	Up to 650
Speed:	Up to 35 feet per minute
Feed Opening:	21"
Dimensions:	47" W x 81" L x 63" H
Feed Table Dimensions:	47" W x 23.5" D x 49.5" H
Space Requirements:	79" W x 100.5" L x 118" H
Bin Capacity:	102 gal.
Weight:	1,984 lbs.

Motor Specifications, Power Requirements

Motor Type	Horizontal Geared
Rated Power	7.5KW (10HP)
Operating Voltage	220/380V
Phase	3-Phase
Frequency	50/60Hz
Plug/Receptacle	CS8365 plug included CS8369 receptacle required
Rated Current	25.5A/14.7A
Output RPM	25 RPM/35 RPM
Number of Poles	4
Total Rated Power Pn	7.5KW
Total Rated Current In	26A
Total Fuse Protection	35A

Installation

1. Appropriate power receptacle must be available at installation site.
2. The FD 8902CC is delivered completely assembled (although it can be delivered in parts, if necessary.) During transport, be aware of the shredder's high center of gravity.
3. The shredder can be moved on its casters. If a fork-lift is used to transport the machine, be sure to use the designated pick-up points.
4. Install the shredder on a flat and even floor without carpeting.
5. Once the shredder is in place, lock the caster brakes, and plug in power cable to appropriate power source.



Power Plug

Installation

Space requirements for operation and maintenance

Left Side View

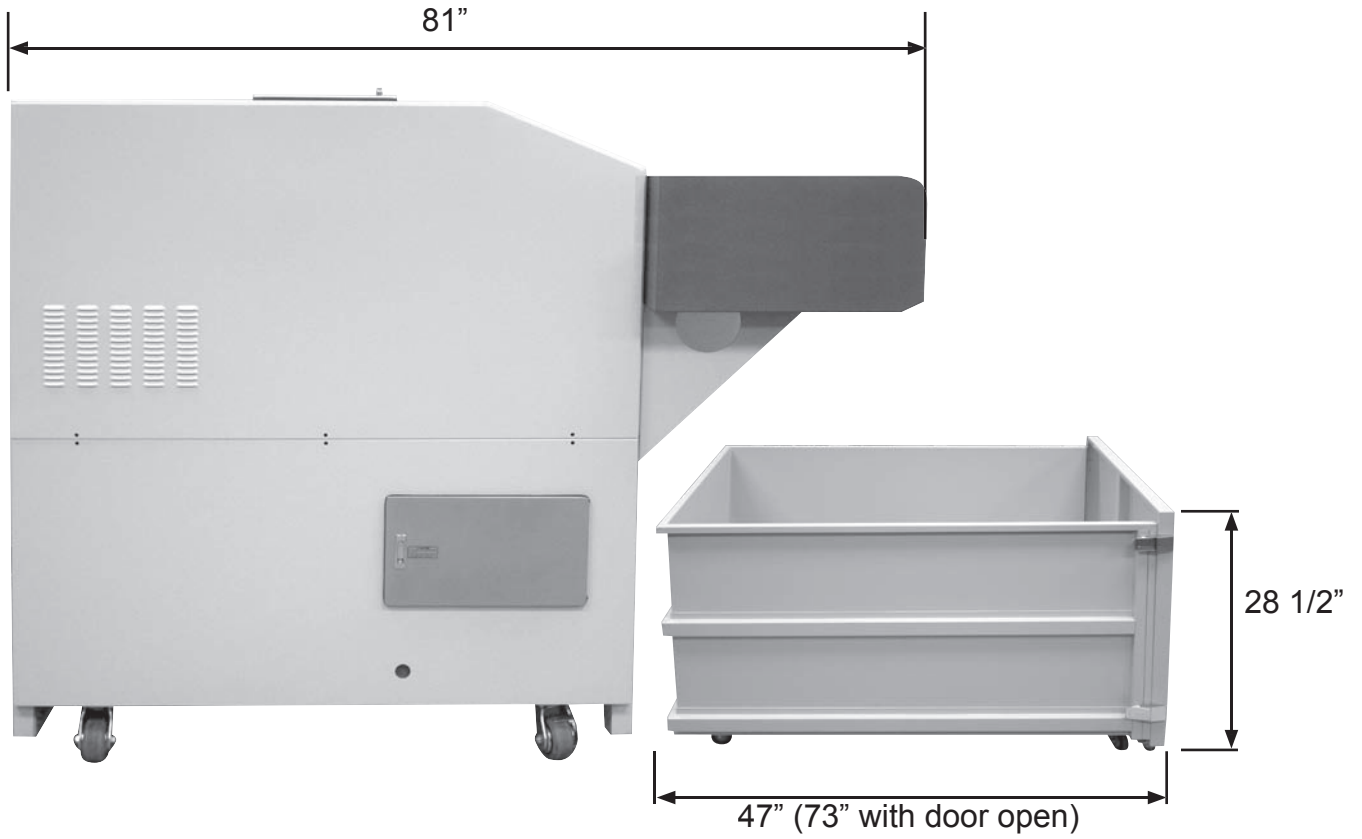

Start-up and Operation

Main Switch

Main Power Switch

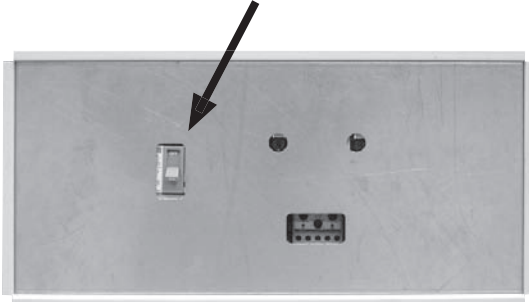

Breaker Panel

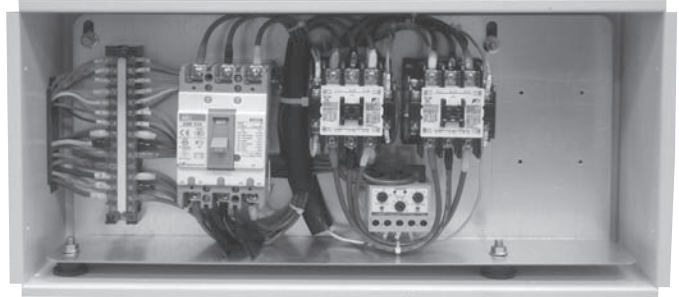

Breaker Panel Interior

Control Panel

LOAD INDICATOR

LED Display

Displays load to provide maximum capacity and avoid paper jams.

REVERSE

Blue Touch Pad

Push button to reverse direction of cutting blades.

A photograph of the control panel for a FORMAX FD 8902CC shredder. The panel is grey and features several controls: an emergency stop button on the left, a row of seven LED indicators in the center, a reverse button, a stop button, a start button, and a key-operated toggle switch on the right. The text 'FORMAX AUTO CROSS CUT SHREDDER' is printed above the LED indicators. Lines connect the descriptive text blocks to their respective controls on the panel.

EMERGENCY STOP
Red Push Button
Push button to stop cutting system. Shredder remains in standby mode until Start button is pressed. (Shredder can also be stopped by pressing red Stop touch pad on right of control panel or large orange Safety Bar on front of shredder.)

MODE/FULL/OPEN INDICATORS
LED Displays
Lights signify mode (Auto/Manual/Stop/Reverse) and indicate when bin is full or door is open.

START A/M
Green Touch Pad
Push once to start Auto Mode: optical sensors cause conveyor and cutting blade to operate. Push twice to choose Manual Mode: conveyor and blades operate continuously.

OFF/ON
Key-Operated Toggle Switch
Turn key to right to turn on cutting system.

Operation

1. Set main switch to ON (page 7). Turn the Key OFF/ON toggle switch on the control panel to the ON position.
2. Press the START button. The conveyor will begin to move in the forward direction.
3. Place the material to be shredded on the feed table, then slide it onto the infeed conveyor belt, in appropriate stacks. (Up to 650 sheets.)

NOTE: If material is accidentally placed onto the conveyor belt, DO NOT REACH FOR IT. Instead, press the red STOP button (left side of control panel) or the Safety Stop Bar (front of feed table). When the shredder stops, press and hold the REVERSE button. The conveyor will operate in reverse, allowing safer access to the materials. The shredder will stop when the REVERSE button is released. To resume shredding, press STOP button, then the START button.

Turning off the shredder

1. To shut down the shredder, press the STOP button on the control panel.
2. Turn Key OFF/ON toggle switch on the control panel to the OFF position (to the left).
3. Open the electrical control panel door, and flip the main power switch DOWN to the off position.

Overloading the motor

If the shred capacity of the machine is exceeded (too large a stack of paper, etc), the shredder will stop automatically. To resume shredding:

1. Push and hold the REVERSE button until the paper or other material backs completely out of the shredder.
2. Press the red STOP button or the SAFETY BAR on the front of the machine, then divide the materials into smaller stacks.
3. Press the START button. The conveyor and cutting blades will begin to move.
4. Continue shredding, feeding less paper or fewer materials at a time.

Oiling Cutting Blades with semiautomatic EvenFlow Oiling System

To keep the cutting blades in peak operating condition, Formax recommends using the EvenFlow Oiler prior to the initial use, large shredding jobs, or whenever shred capacity appears to be decreased.

1. Open yellow screw-top cap on external pump assembly (see page 19). Fill with Formax 8902 shredder oil. Do not fill above top red line on pump window. Replace cap.
2. To operate, pump the handle two to three times.

Frequent Overloading

If the shredder is repeatedly overloaded, the motor can overheat, which will cause the shredder to switch off automatically. To resume shredding:

1. Allow the motor to cool down for approximately 20 - 30 minutes before using.
2. Once the motor has cooled sufficiently, resume shredding by following standard operating procedure.



NOTE:

To maintain optimum performance and allow constant operation, avoid repeatedly overloading the shredder. This will prevent time-consuming reversing cycles, and will provide the highest possible throughput.

Emptying the Waste Bin

Shredded paper and particles accumulate in the shredder waste bin during normal operation. When the “Waste Bin Full” lamp lights, empty the waste bin.

1. Switch the shredder off by pressing the STOP button on the control panel, turn the Key OFF/ON toggle switch to the OFF position and flip the main power switch to the OFF position.
2. Grasp handle on waste bin and pull straight out. Gather sides of shredder bag using drawstring. Flip open two latches on front left of waste bin (see page 4), swing open door and slide bag out. Close and latch door. Empty and replace bag.
3. Push the waste bin in, turn power switches back on and resume shredding.

Maintenance and Inspection



NOTE: The maintenance procedures which follow should be performed only by authorized and trained technicians.

Removing & Reinstalling Side Covers

Side covers are each attached by three Phillips head screws.

1. To remove covers, insert screwdriver through access holes (Fig. 1), and remove screws. Lift covers off frame hooks.
2. To reinstall, rest panels on hooks, replace screws.

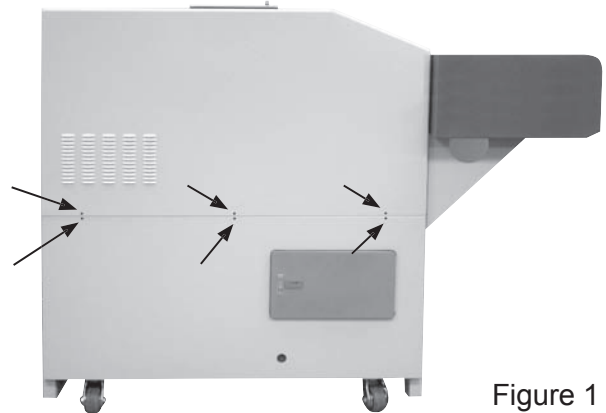

Figure 1

Conveyor Belt Maintenance

- **Checking Belt Tension**
When loaded with material, the conveyor belt must not slip, i.e. stand still when material is loaded. If the belt slips, it must be tightened. Contact the Formax Service Department for assistance.
- **Checking Belt for Wear**
The upper surface of the conveyor belt can become worn over time. The belt must be replaced when the woven fabric inlay becomes visible. Contact the Formax Service Department for assistance.
- **Cleaning the Conveyor Belt area**
The conveyor belt area must be cleaned once a month, or as needed to maintain optimal performance.
 1. Switch off the shredder and unplug from wall outlet.
 2. Remove the covers on both sides, revealing the cleaning openings in the conveyor belt area.
 3. Use compressed air to blow out particles, or a vacuum to remove dirt and dust.
 4. Re-install side covers.

NOTE: Paper clips in the shredded materials may increase the frequency of cleaning necessary, and may become caught in the sides of the belt.

- **Cleaning the Conveyor Belt Tensioning Station**

The tensioning station must be cleaned once a month, or as needed to maintain optimal performance.

1. Switch off the shredder and unplug from wall outlet.
2. Remove the feed table and front panel of tensioning station (Fig. 2).
3. Remove particles and dirt.
4. Re-install the feed table and front panel of tensioning station.

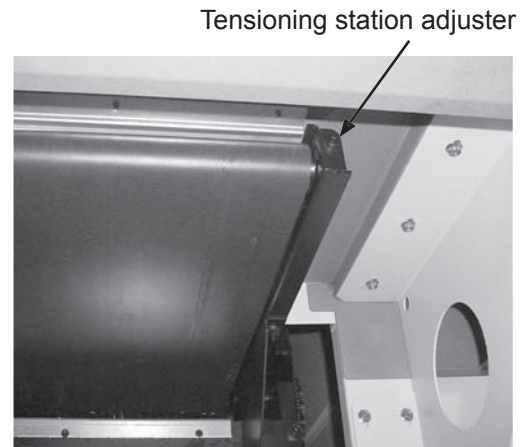

Fig. 2 Underside View of Feed Table and Infeed Conveyor

- **Checking the Cutting Head Chain Tension**

Check the chain tension once every week in the first month, then once a month thereafter.

1. Switch off the shredder and unplug from wall outlet.
2. Remove the top right side cover.
3. The sagging of the chain (see Fig. 3) should be 9 - 14 mm, measured from the top inside of the frame to the cutting head chain.

If it is not within this range, loosen the tension screws until the sagging reaches the correct level. Retighten the tension nuts.

4. Replace the side cover, plug in the shredder.



NOTE:

Excessive tensioning of the chain can cause premature wear of the chain and bearings. The smallest allowed chain sagging in the first month of operation is 5 mm. After that, 9 mm.

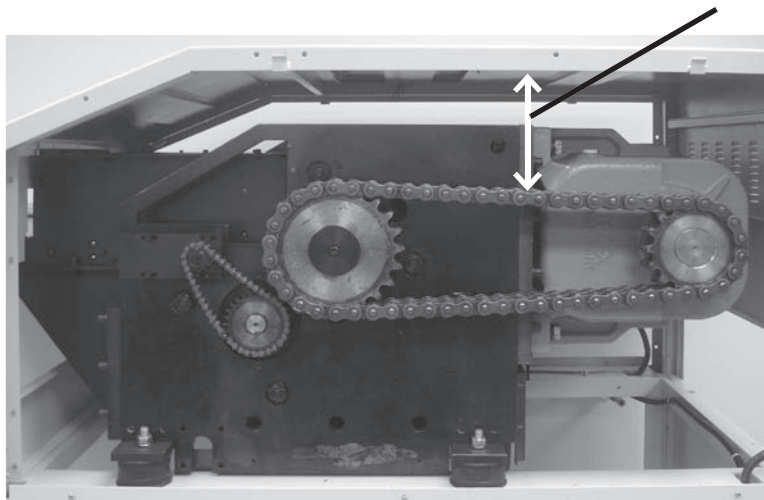

Fig. 3

Lubricating Shredder Mechanisms

- Cutting System:

The cutting system should be oiled once a month or as needed for optimal performance.

1. Open the Cutting Block Access Door on the top of the shredder. Press latch and the handle will spin around. Pull up on the handle.
2. Spray special cutting block oil through the paper inlet, onto the cutter rolls.
3. Close the Access Door and press the START button on the control panel.
4. Run the cutting system forward and backward several times, *without feeding paper*. This will help to remove paper shreds and particles.

- Drive Chains:

The drive chains should be checked during PMs, and greased as needed.

1. Switch off the shredder and unplug from wall outlet.
2. Remove both top side covers.
3. Grease the cutting system conveyor belt drive chain (A) and the motor cutting system drive chain (B).
4. Replace side covers and plug in shredder.

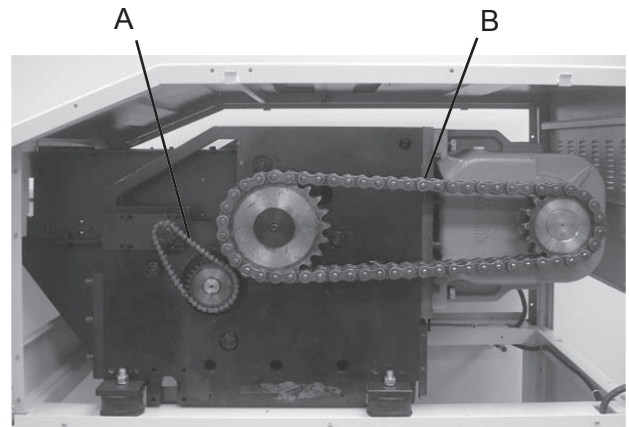

Right Side

- Synchronizing Wheels:

1. Switch off the shredder and unplug from wall outlet.
2. Remove left top side cover.
3. Grease the synchronizing toothed wheel (C).
4. Replace side cover and plug in shredder.

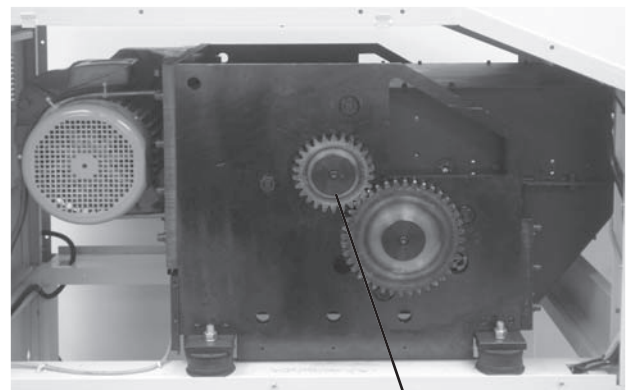

Left Side

Exterior cleaning

- Turn shredder off and unplug from wall outlet.
- Wipe the exterior surfaces with a soft cloth. If the surfaces are very dirty, use a neutral detergent, then wipe again with a soft cloth.

CAUTION:

- Never put water directly on the surface of the shredder.
- Never clean the case with benzene or thinner, since it will cause discoloration.

PARTS LISTS

Front View

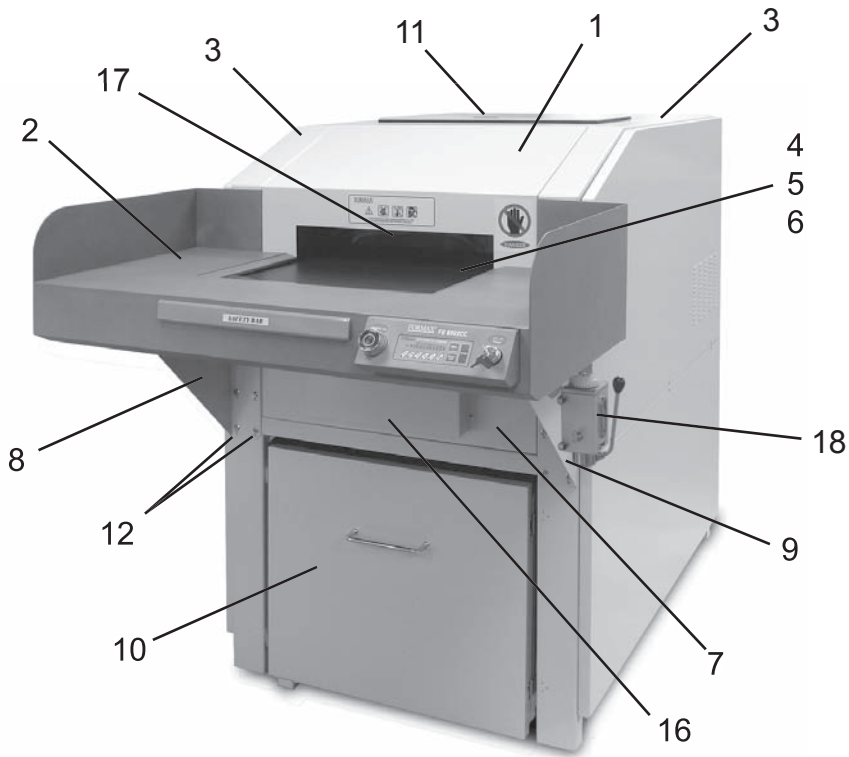

Rear View

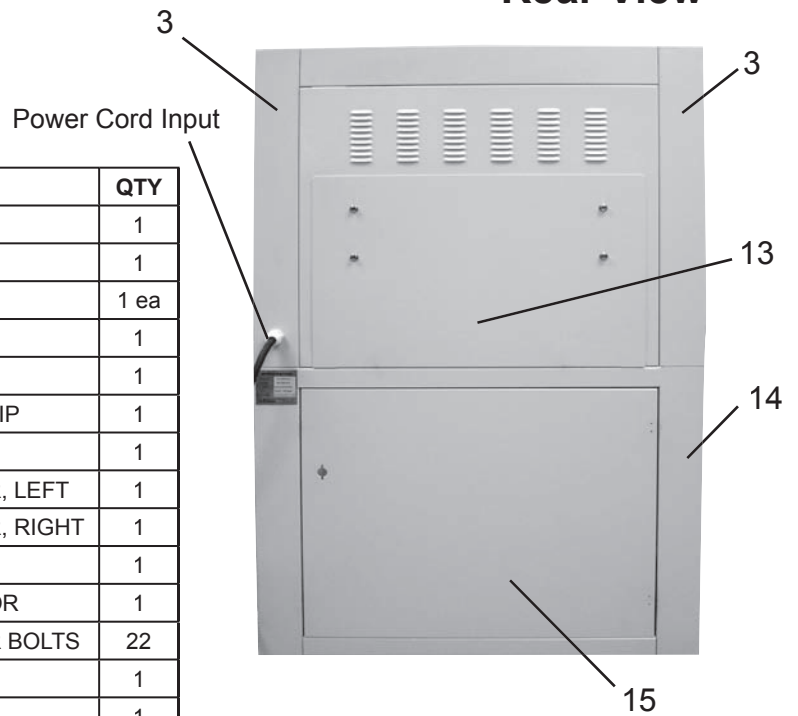

ITEM	PART #	DESCRIPTION	QTY
1	8902-TOP-01	TOP CASE	1
2	8902-TOP-02	LOADING TABLE	1
3	8902-TOP-03	UPPER FRAME (LEFT, RIGHT)	1 ea
4	8902-CON-01	CONVEYOR BELT ASSEMBLY	1
5	8902-BEL-01	CONVEYOR BELT	1
6	8902-BEL-02	CLEAR PLASTIC SAFETY STRIP	1
7	8902-TOP-05	FRONT CASE	1
8	8902-TOP-06L	LOADING TABLE SUPPORTER, LEFT	1
9	8902-TOP-06R	LOADING TABLE SUPPORTER, RIGHT	1
10	8902-WST-01	WASTE BIN	1
11	8902-TOP-07	CUTTING HEAD ACCESS DOOR	1
12	8802-BOL-01	LOADING TABLE SUPPORTER BOLTS	22
13	8902-TOP-04	REAR CASE	1
14	8902-BOD-01	LOWER FRAME	1
15	8902-BOD-02	REAR CASE, LOWER	1
16	8902-PCB-13	PCB COVER	1
17	8902-PCB-14	PHOTO-EYE SENSOR	1
18	8902-OIL-22	EVENFLOW OILER PUMP ASSEMBLY	1

Left Side

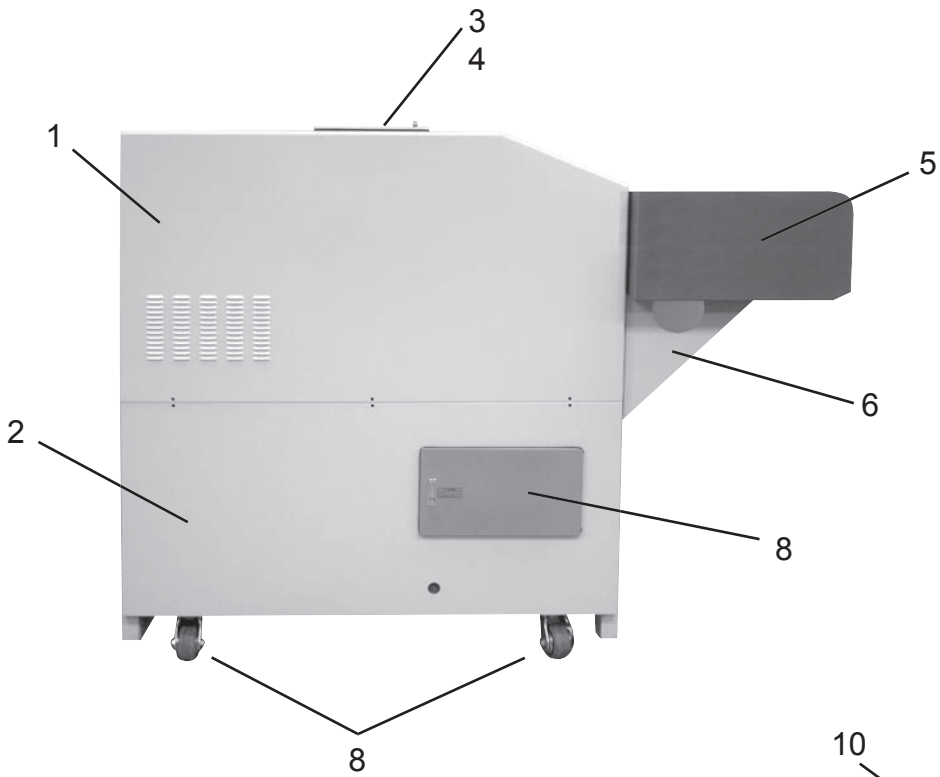

Right Side

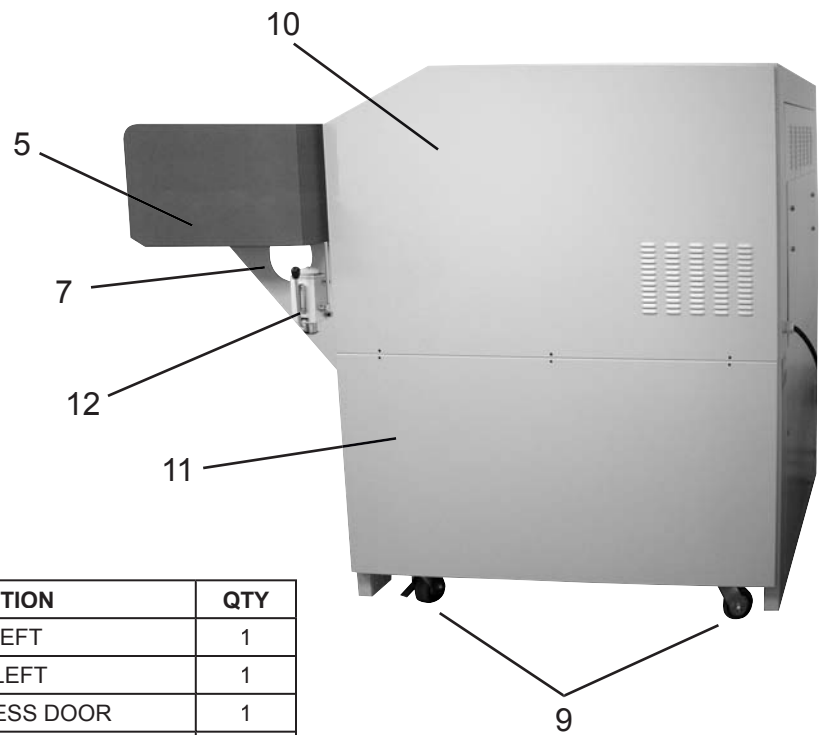

ITEM	PART #	DESCRIPTION	QTY
1	8902-BOD-04	UPPER SIDE CASE, LEFT	1
2	8902-BOD-06	LOWER SIDE CASE, LEFT	1
3	8902-TOP-07	CUTTING HEAD ACCESS DOOR	1
4	8802-PCB-07	MICRO SWITCH, ACCESS DOOR	1
5	8902-TOP-02	LOADING TABLE	1
6	8902-TOP-06L	LOADING TABLE SUPPORTER, LEFT	1
7	8902-TOP-06R	LOADING TABLE SUPPORTER, RIGHT	1
8	8902-PCB-02	ELECTRICITY CONTROL BOX DOOR	1
9	8902-CAT-01	BODY CASTERS	4
10	8902-BOD-03	UPPER SIDE CASE, RIGHT	1
11	8902-BOD-05	LOWER SIDE CASE, RIGHT	1
12	8902-OIL-22	EVENFLOW OILER PUMP ASSEMBLY	1

WASTE BIN (FD 8902CC)

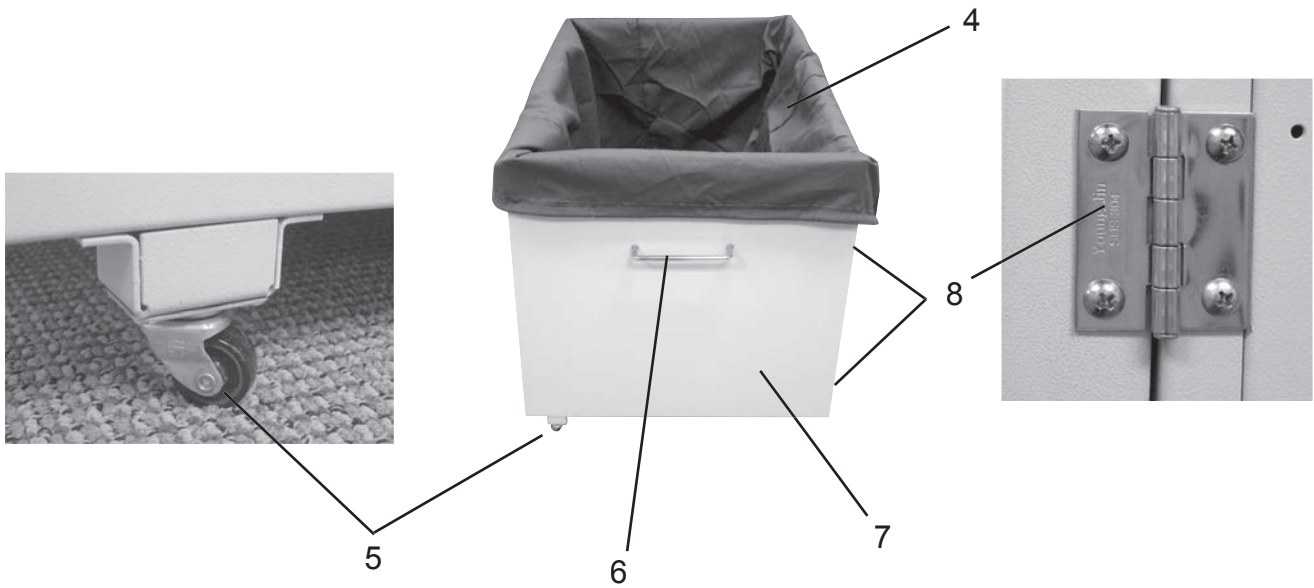
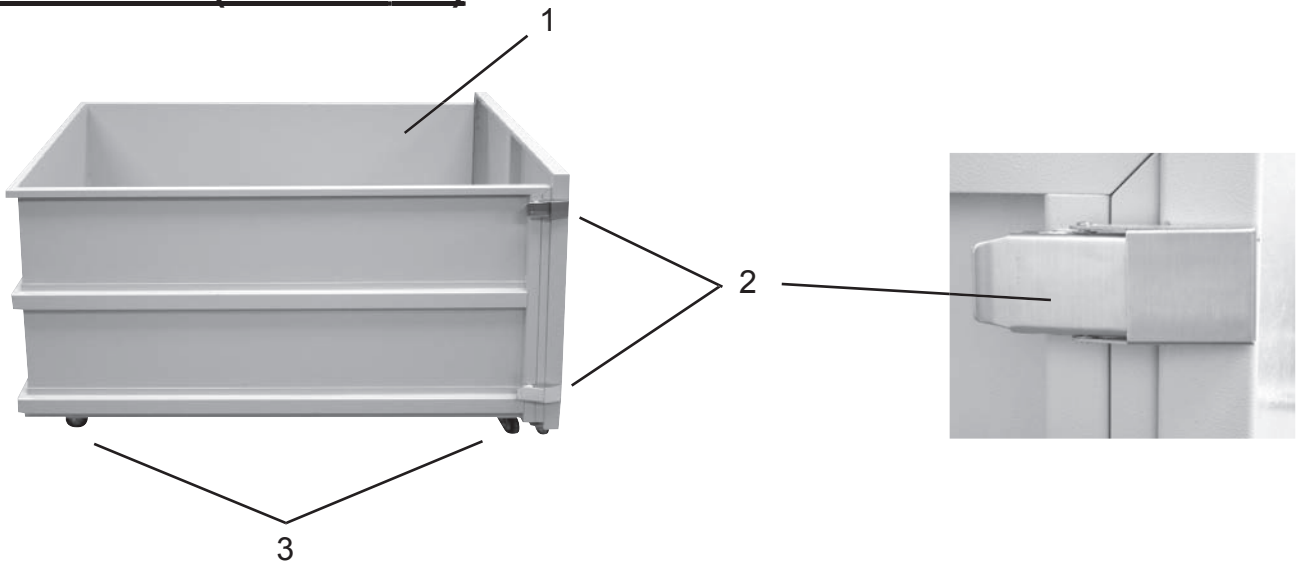

ITEM	PART #	DESCRIPTION	QTY
1	8902-WST-01	WASTE BIN	1
2	8902-WST-02	WASTE BIN DOOR LATCHES	2
3	8902-WST-03	WASTE BIN CASTERS	4
4	8000-95	NYLON WASTE BIN BAG	2
5	8902-WST-04	WASTE BIN DOOR CASTER	1
6	8902-WST-05	WASTE BIN DOOR HANDLE	1
7	8902-WST-06	WASTE BIN DOOR	1
8	8902-WST-07	WASTE BIN DOOR HINGES	2

CUTTING HEAD

Right Side

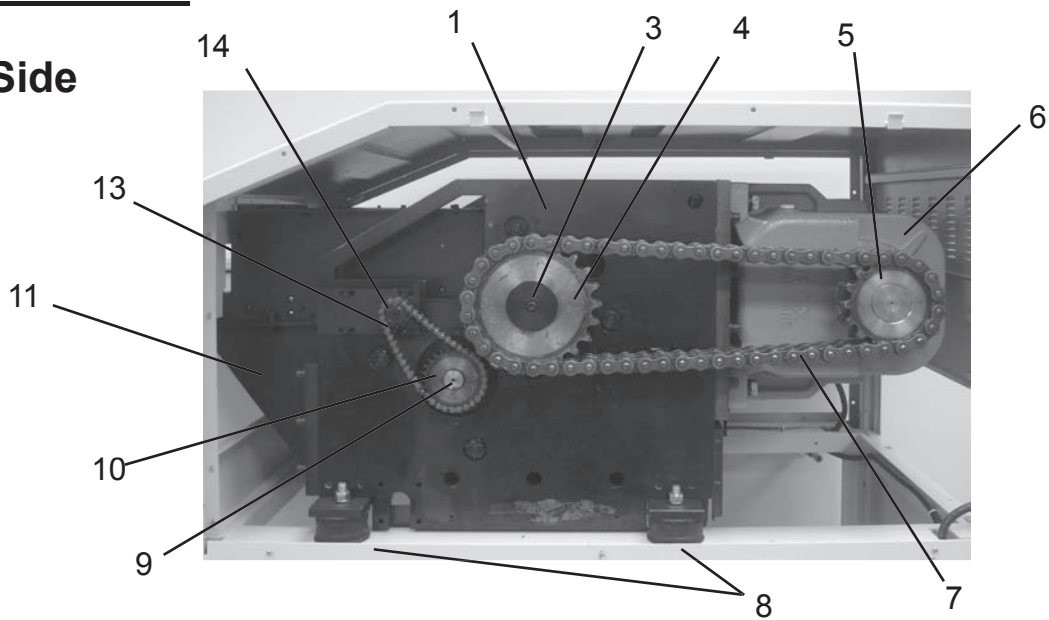

Left Side

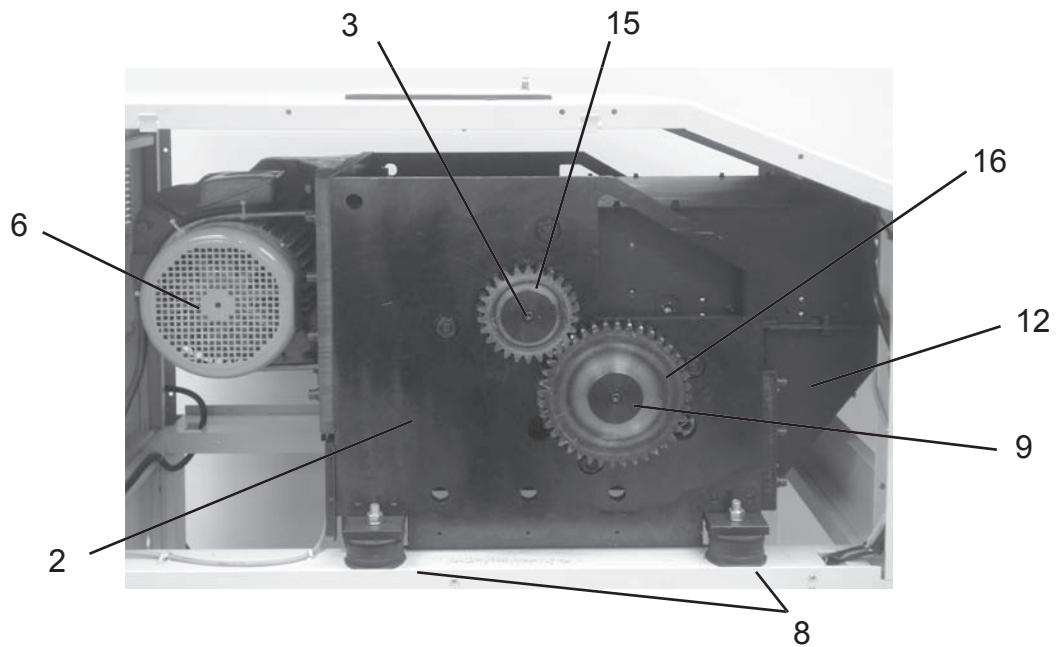

ITEM	PART #	DESCRIPTION	QTY
1	8902-CTB-02	SIDE PLATE, RIGHT	1
2	8902-CTB-01	SIDE PLATE, LEFT	1
3	8902-CTB-07	LONG SHAFT	1
4	8902-GEA-01	GEAR	1
5	8902-SPR-03	MOTOR SPROCKET	1
6	8902-MOT-01	MOTOR (220V, 60Hz, 10HP)	1
7	8902-CCH-01	CUTTING HEAD CHAIN	1
8	8902-RUB-01	VIBRATION-PROOF RUBBER (100)	4
9	8902-CTB-08	SHORT SHAFT	1
10	8902-SPR-01	CONVEYOR SPROCKET	1
11	8902-CON-03R	CONVEYOR BELT BRACKET, RIGHT	1
12	8902-CON-03L	CONVEYOR BELT BRACKET, LEFT	1
13	8902-CCH-02	CONVEYOR CHAIN	1
14	8902-SPR-02	CONVEYOR DRIVE SPROCKET	1
-	8902-CTB-00	CUTTING HEAD	

ELECTRICAL

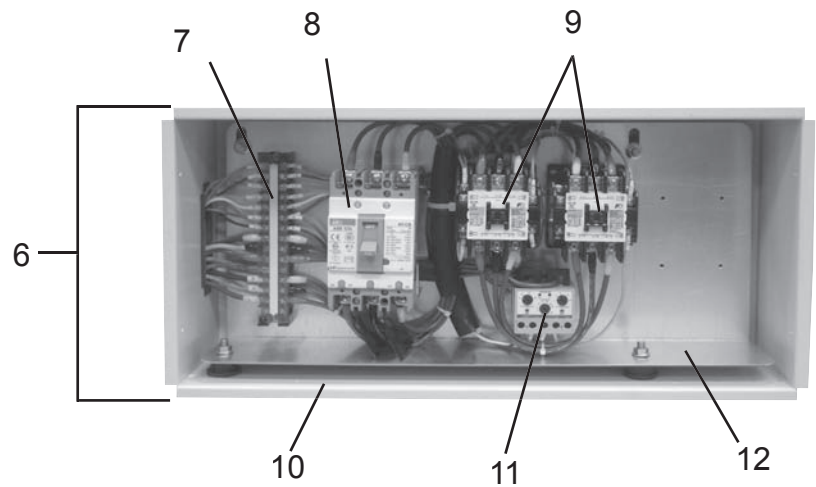
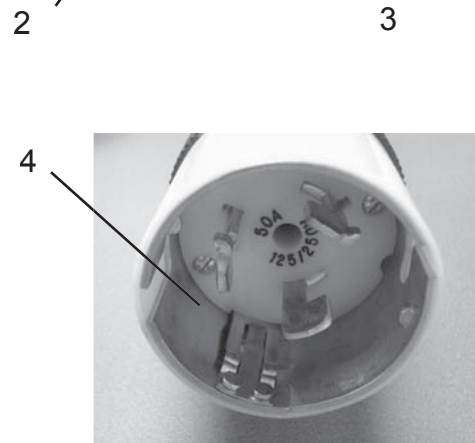
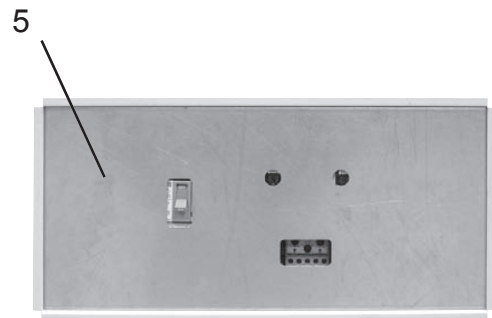
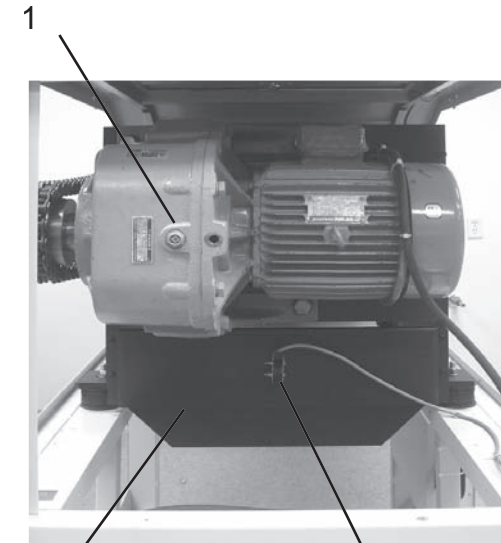

ITEM	PART #	DESCRIPTION	QTY
1	8902-MOT-01	MOTOR (220V, 60Hz, 10HP)	1
2	8902-CTB-20	WASTE GUIDE, REAR	1
3	8902-CTB-21	MICRO SWITCH, WASTE BIN FULL SENSOR, 15A	1
4	8902-PCB-10	POWER PLUG	1
5	8902-PCB-15	ELECTRICITY CONTROL BOX COVER	1
6	8902-PCB-00	ELECTRICITY CONTROL ASSEMBLY	1
7	8902-PCB-05	WIRE TERMINAL PLATE	1
8	8902-PCB-09	BREAKER	1
9	8902-PCB-06	MAGNETIC CORE	2
10	8902-PCB-03	ELECTRICITY CONTROL BOX	1
11	8902-PCB-04	EOCR	1
12	8902-PCB-01	ELECTRICITY CONTROL BOX BASE	1

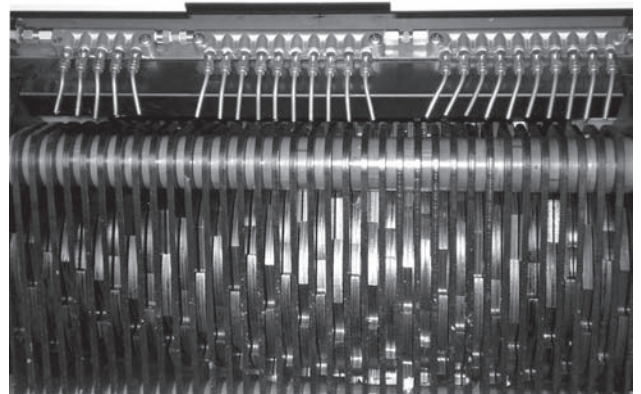
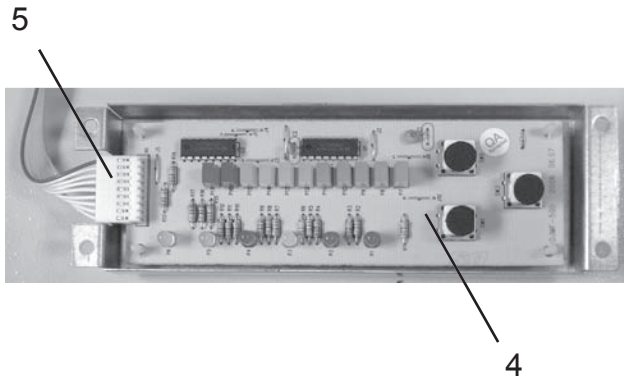
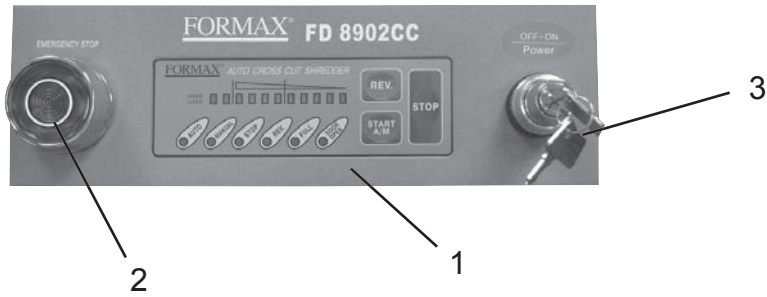

CUTTING HEAD ASSEMBLY

ITEM	PART #	DESCRIPTION	QTY
1	8902-PCB-23	CONTROL PANEL	1
2	8902-PCB-24	EMERGENCY STOP BUTTON	1
3	8902-PCB-25	KEY	2
4	8902-PCB-12	CONTROL PANEL PCB	1
5	8902-PCB-16	BODY CABLE	1
-	8902-CTB-09	CUTTER	-
-	8902-CTB-10	RING	
-	8902-CTB-11	BEARING (6208ZZ)	
-	8902-CTB-12	CUTTER PRESS WASHER	
-	8902-CTB-13	BEARING WASHER	
-	8902-CTB-14	BEARING NUT	
-	8902-CTB-15	CUTTER NUT	
-	8902-CTB-16	BEARING HOUSING	
-	8902-CTB-17	GUIDE REINFORCEMENT PLATE	
-	8902-CTB-18	UPPER GUIDE	
-	8902-CTB-19	LOWER GUIDE	
-	8902-CON-02	CONVEYOR SHAFT HOLDER	
-	8902-CTB-07	LONG SHAFT	
-	8902-CTB-08	SHORT SHAFT	
-	8902-CTB-03	POST	

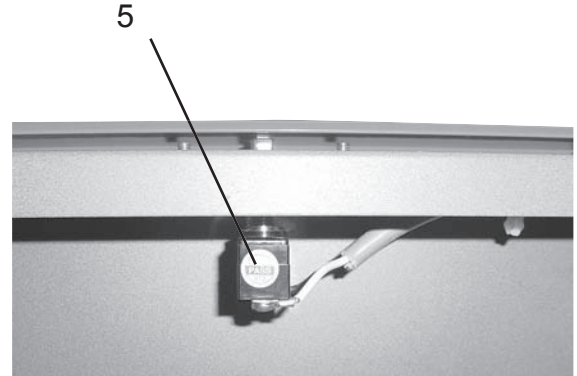
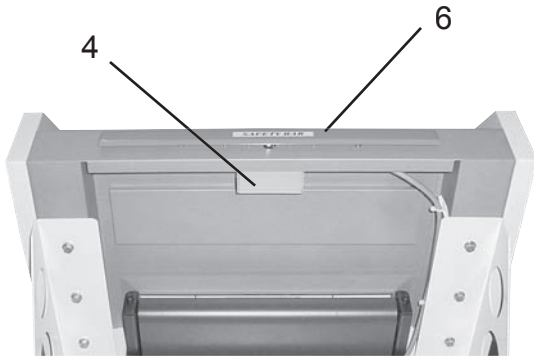
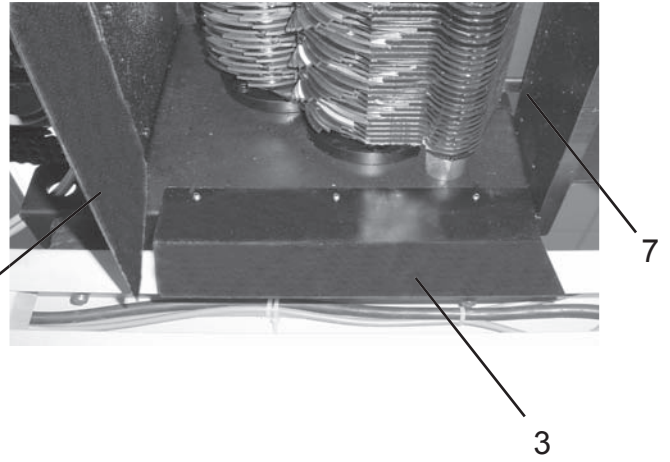
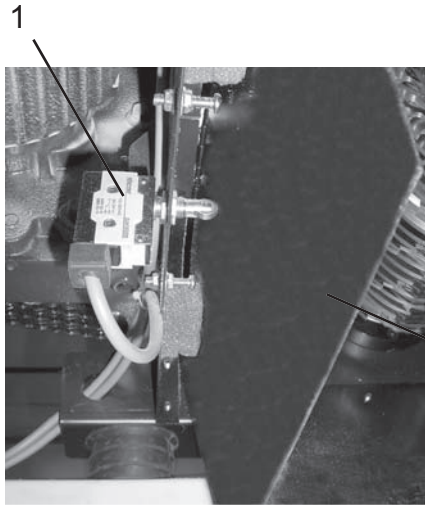

Underside View, Feed Table and Conveyor

Underside View, Safety Bar and Micro Switch

ITEM	PART #	DESCRIPTION	QTY
1	8902-PCB-08	MICRO SWITCH, WASTE BIN FULL	1
2	8902-CTB-20	WASTE GUIDE, REAR	1
3	8902-CTB-06	WASTE GUIDE, LEFT & RIGHT	1 EA
4	8902-PCB-20	MICRO SWITCH, SAFETY BAR	1
5	8902-PCB-21	MICRO SWITCH HOUSING FOR SAFETY BAR	1
6	8902-PCB-22	SAFETY BAR	1
7	8902-CTB-04	FRONT WASTE PROOF PLATE	1

EVENFLOW OILING SYSTEM

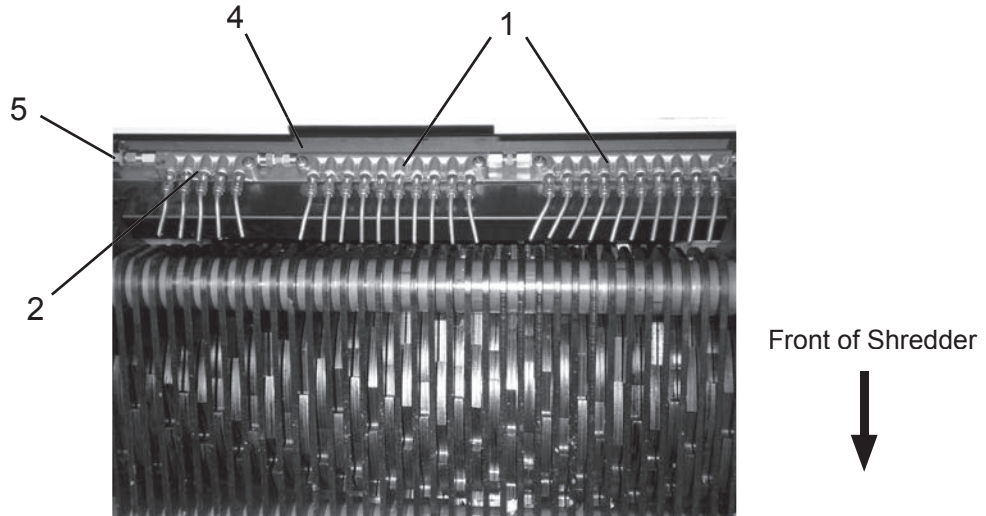

Top View with
Access Door open

ITEM	PART #	DESCRIPTION	QTY
1	8902-OIL-20	OIL NOZZLE, 10 PIECE	2
2	8902-OIL-21	OIL NOZZLE, 5 PIECE	1
3	8902-OIL-22	OIL PUMP	1
4	8902-OIL-23	OIL NOZZLE BRACKET	1
5	8902-OIL-24	OIL HOSE	1
6	8902-OIL-25	PUMP MOUNTING SCREWS	4
-	8902-OIL-26	NOZZLE BRACKET MOUNTING SCREWS	4

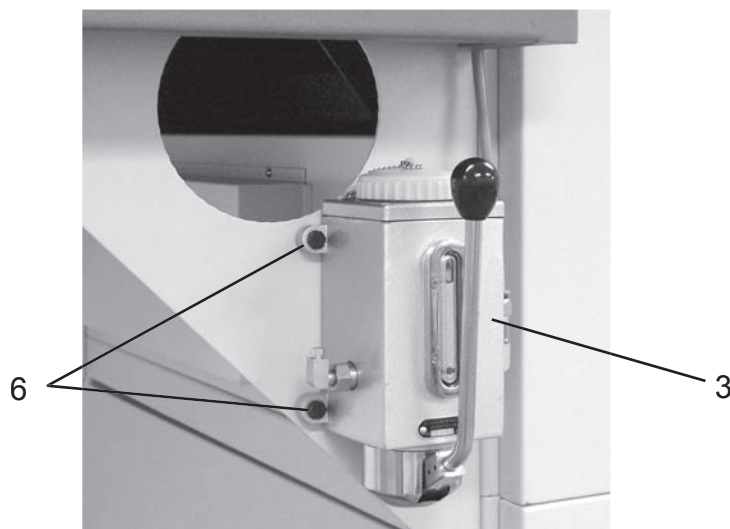

OPTIONAL 8900-10 CONVEYOR

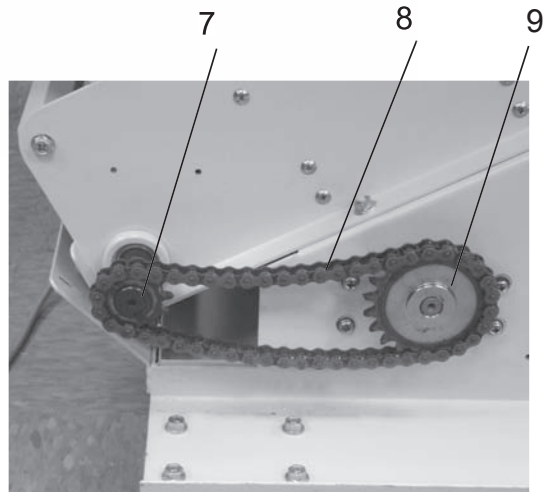
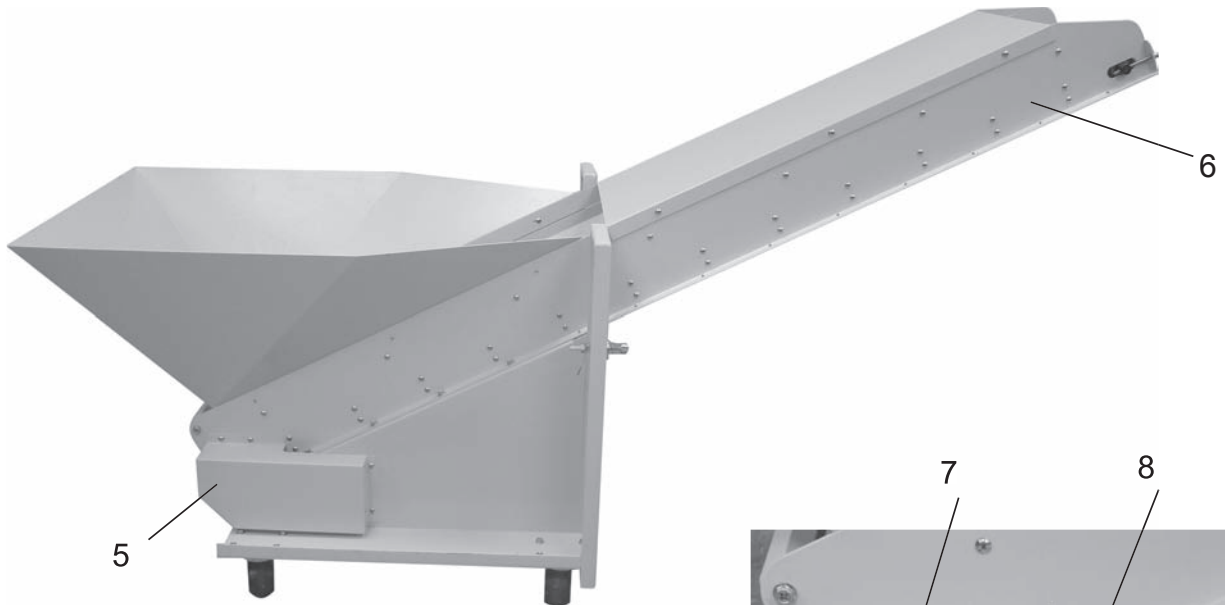
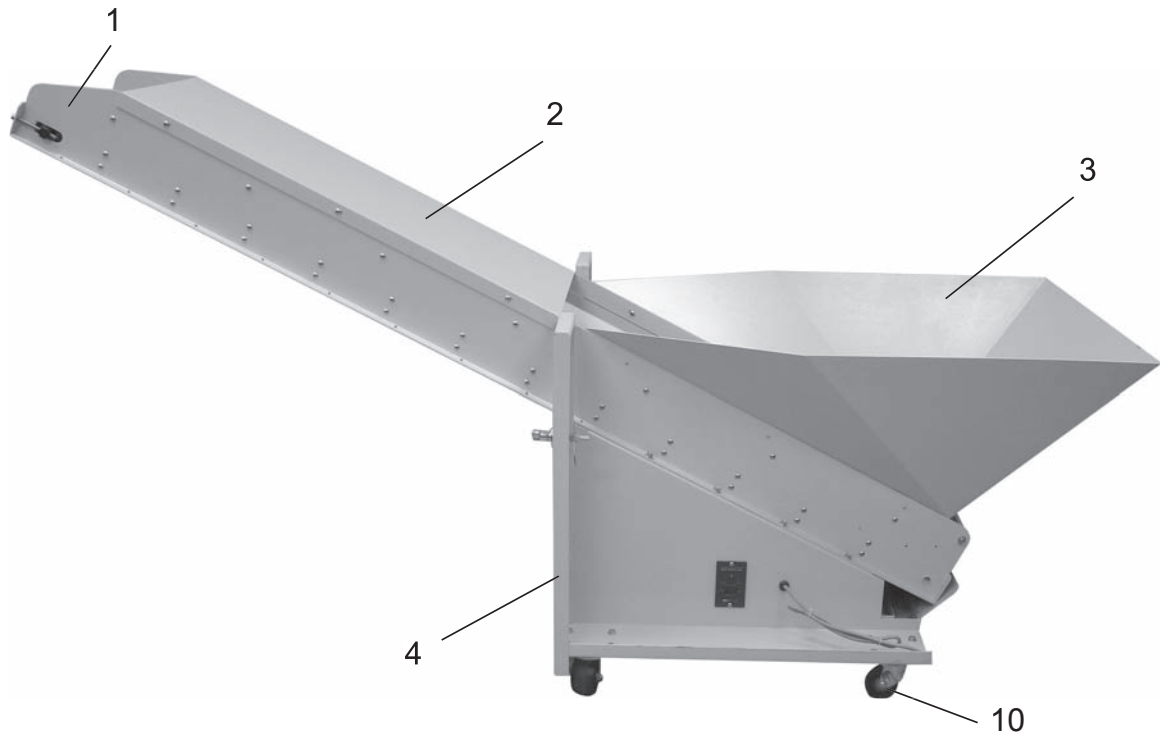

ITEM	PART #	DESCRIPTION	QTY
1	8900-CB-01	CONVEYOR SIDE, LEFT	1
2	8900-CB-02	COVER	1
3	8900-CB-03	HOPPER	1
4	8900-CB-04	BODY CASE	1
5	8900-CB-05	CHAIN COVER	1
6	8900-CB-06	CONVEYOR SIDE, RIGHT	1
7	8900-CB-07	CHAIN SPROCKET (A)	1
8	8900-CB-08	CHAIN	1
9	8900-CB-09	CHAIN SPROCKET (B)	1
10	8900-CB-10	CASTER	4

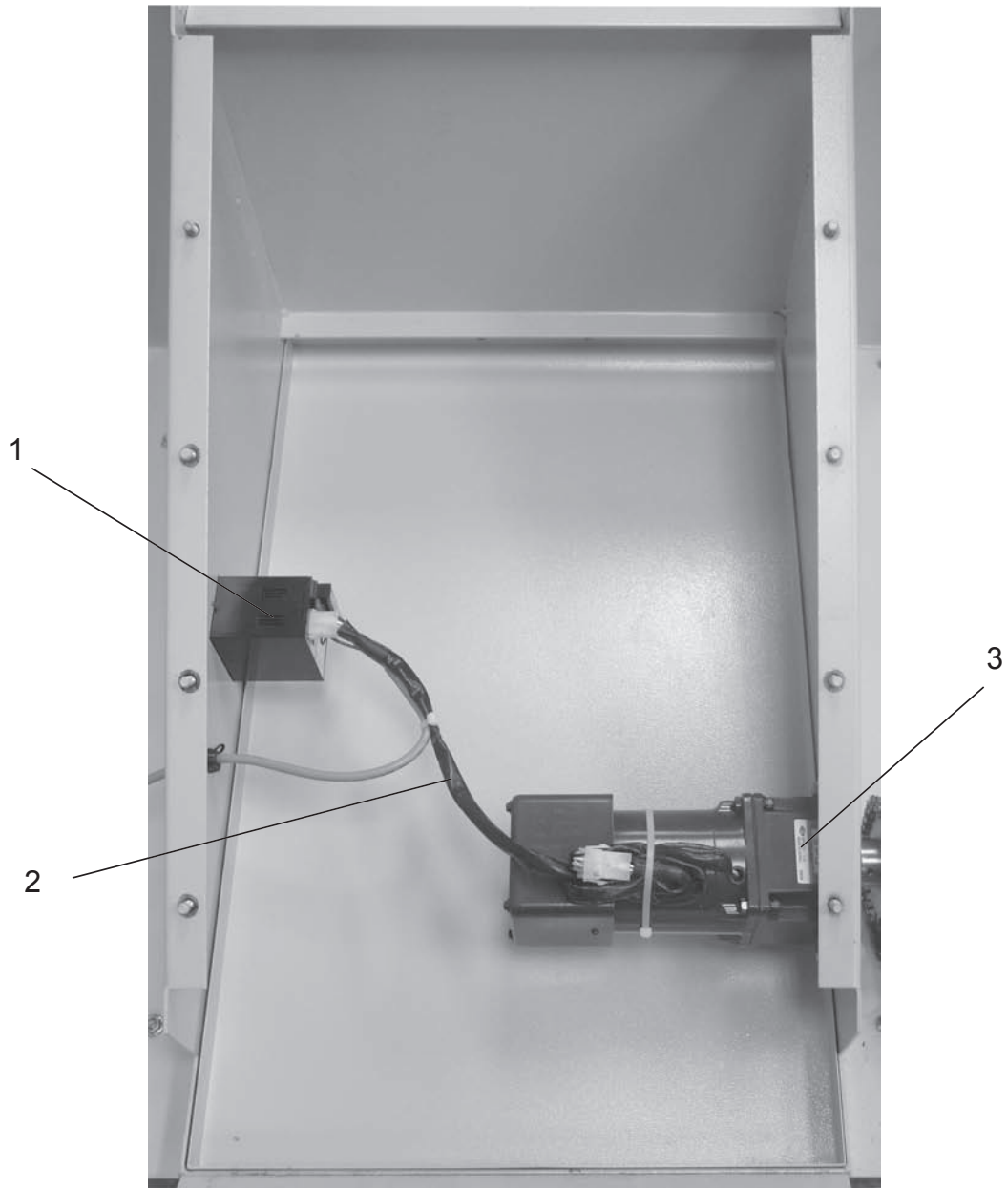

ITEM	PART #	DESCRIPTION	QTY
1	8900-CB-11	CONTROLLER	1
2	8900-CB-12	HARNESS CABLE	1
3	8900-CB-13	MOTOR	1

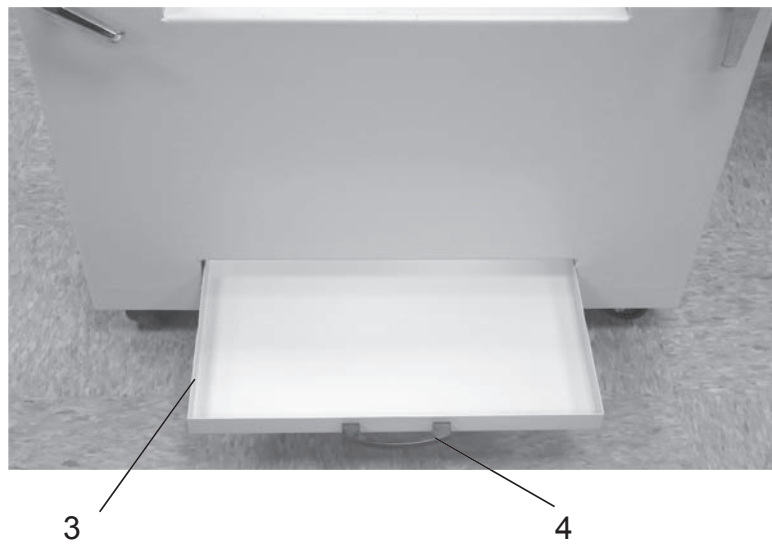
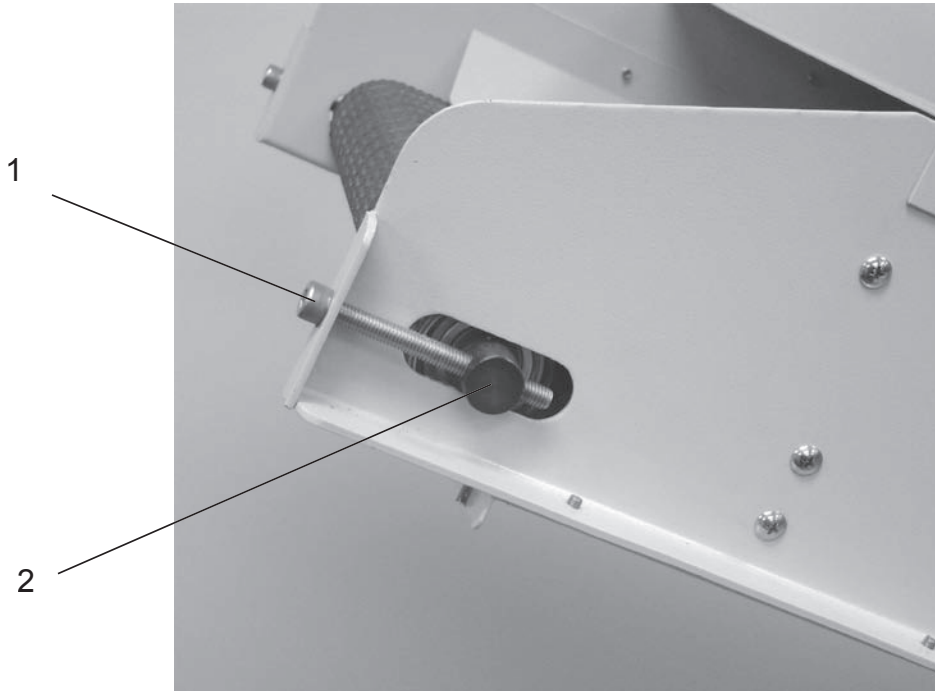

ITEM	PART #	DESCRIPTION	QTY
1	8900-CB-14	CONVEYOR TENSION BOLT	2
2	8900-CB-15	CONVEYOR POST	1
3	8900-CB-16	WASTE PLATE	1
4	8900-CB-17	WASTE PLATE HANDLE	1

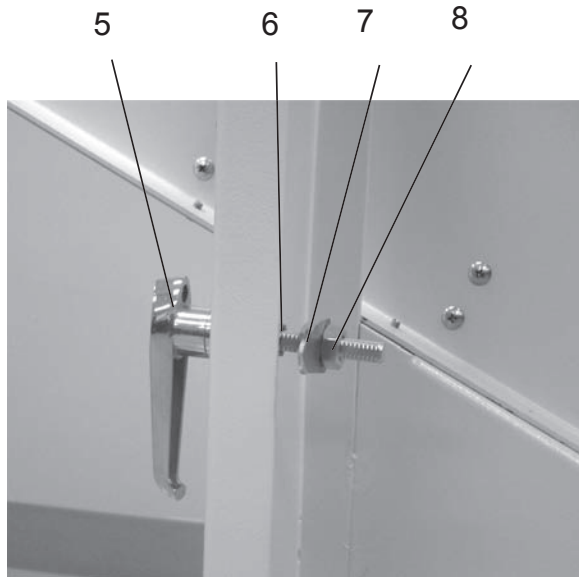
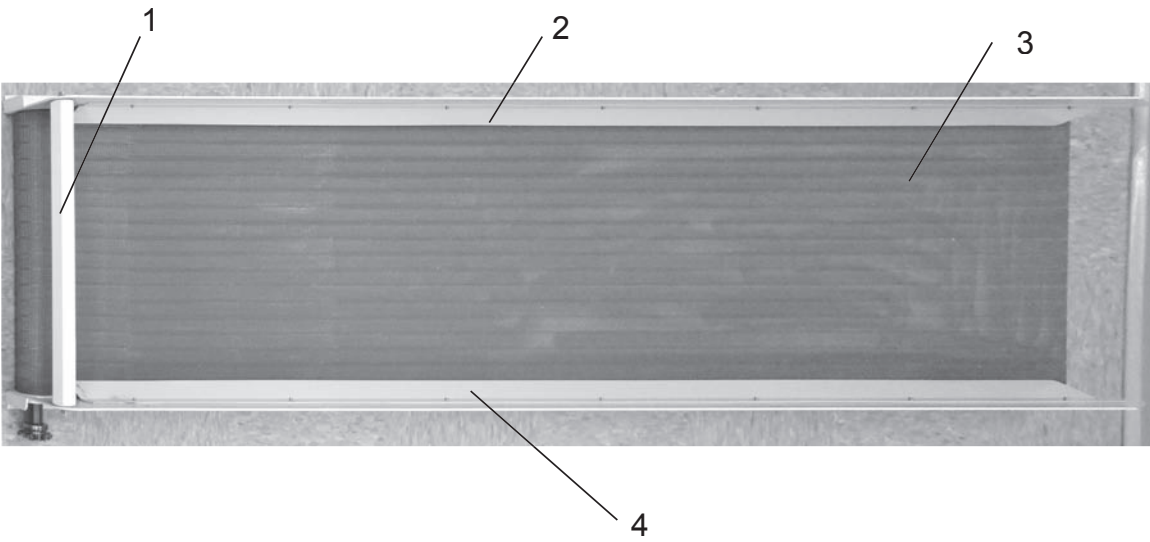

ITEM	PART #	DESCRIPTION	QTY
1	8900-CB-18	STOPPER	1
2	8900-CB-19	GUIDE, RIGHT	1
3	8900-CB-20	CONVEYOR BELT	1
4	8900-CB-21	GUIDE, LEFT	1
5	8900-CB-22-1	DOOR HANDLE	2
6	8900-CB-22-2	DOOR BOLT	2
7	8900-CB-22-3	DOOR LATCH	2
8	8900-CB-22-4	LATCH NUT	2
-	8900-CB-22	DOOR HANDLE ASSEMBLY	-