

FORMAX[®]

Atlas C350

Automatic Air-Feed Programmable Folder/Creaser

 **WARNING:**

This is a Class A product. In a domestic environment this product may cause radio interference in which case the user may be required to take adequate measures.

The product (System) which is connected to this machine will be class A.

 **NOTE:**

The domestic environment is an environment where the use of broadcast radio and television receivers may be expected within a distance of 10m of the apparatus concerned.

Introduction

This manual contains instructions on the operation and maintenance of this machine. To get maximum versatility from this machine all operators should carefully read and follow the instructions in this manual. Keep this manual in a handy place near the machine.

Please read the Safety Information before using this machine. It contains information related to USER SAFETY and PREVENTING EQUIPMENT PROBLEMS.

How to Read This Manual

Notation Conventions

Whenever necessary, the following points for attention are indicated in this manual.

WARNING:

Indicates a potentially hazardous situation which, if instructions are not followed, could result in death or serious injury.

CAUTION:

Indicates a potentiality hazardous situation which, if instructions are not followed, may result in minor or moderate injury or damage to machine or property.

NOTE:

This sign refers to:

- *Remarks for making the operation much easier. You get practical hints or knowledge to assist you in the machine operation such as:*
- *Preparations required before operating*
 - *How to prevent papers from being misfed or damaged*
 - *Precautions required or actions to take after misoperation*
- *Limitations like numerical limits, functions that cannot be used together or conditions, under which a particular function cannot be used or obtained.*

Safety Information

When using this machine, following safety precautions should always be followed.

Safety During Operation

WARNING:

- To avoid hazardous situations like for instance electric shock or danger while exposed to moving, rotating or cutting devices, do not remove any covers, guards or screws other than those specified in this manual.
- Turn off the power and disconnect the power plug (by pulling the plug, not the cable) if any of the following conditions exists:
 - You drop objects or spill something into the equipment.
 - You suspect that your equipment needs service or repair.
 - Your equipment's covers has been damaged.
 - You notice unusual noises or odours when operating the equipment.
 - If the power cable or plug becomes worn out or otherwise damaged.
 - Before cleaning and care (unless otherwise specifically instructed).
- Electromagnetic compliance:
 - This is a Class A product. In a domestic environment this product may cause radio interference in which case the user may be required to take adequate measures.
 - The product (System) which is connected to this machine will be class A.

General Safety

WARNING:

- Always connect the equipment to a properly grounded power source (wall outlet). If in doubt, have the power source checked by a qualified electrician.
- Improper grounding of the equipment can result in electrical shock. Never connect the machine to a power source that lacks a ground connection terminal. This machine is destined for specific purpose only. Any use going beyond this specific purpose is regarded as beyond the determination. The manufacturer will not be liable for damages resulting from any use beyond the determination, unallowed operation, respectively. The user alone bears the risk.
- Do not make arbitrary changes or modifications to the machine. The manufacturer will not be liable for modifications made at the machine on your own and damages resulting thereof. EC declaration of conformity and the mark CE will be invalidated, if you make changes at the machine or at the individual components.
- Do not override or bypass electrical or mechanical interlock devices.
- The machine is to be used only by authorized and instructed persons. The responsibilities on operating the machine have to be strictly laid down and observed so that there are no unclear competencies regarding safety aspects.
- Vent holes serve for air circulation to protect the machine from overheating. Make sure that the holes are not covered.
- Do not expose fingers or other parts of the body to moving, rotating or cutting devices such as for instance between upper and lower trimmer knives.
- Always locate the equipment on a solid support surface with adequate strength for the weight of the machine.

Continued on next page...

 **CAUTION:**

- *The machine and its peripherals must be installed and maintained by a customer service representative who has completed the training course on those models.*
- *Always follow all warnings marked on, or supplied with, the equipment.*
- *When you disconnect the power plug from the wall outlet, always pull the plug (not the cable).*
- *Disconnect the power cord before you move the machine. While moving the machine, always exercise care and make sure that the power cord will not be damaged under the machine.*
- *Always contact service if relocating the equipment.*
- *Do not move the machine while the machine is running.*
- *Do not open covers while the machine is running.*
- *Do not switch off the power while the machine is running. Make sure the machine cycle has ended.*
- *Lay the power cord in a way that nobody will stumble over it. Do not place things on the cord.*
- *Never attempt any maintenance function that is not specifically described in this documentation.*
- *Always keep magnets and all devices with strong magnetic fields away from the machine.*
- *If the place of installation is air-conditioned or heated, do not place the machine where it will be:*
 - *Subject to sudden temperature changes.*
 - *Directly exposed to cool air from an air-conditioner.*
 - *Directly exposed to heat from a heater.*
- *If the machine is not used over an extended period of time it should be unplugged to prevent damage in the case of overload.*

 **NOTE:**

- *The operator manual always has to be available at the place of use of the machine.*
- *In the interest of technical development the company reserves the right to make alterations to specifications without prior notice!*

Page intentionally blank.

TABLE OF CONTENTS

What You Can Do With This Machine	9
Guide To Components	10
Atlas C350.....	10
Feeder Module.....	11
Folding Module.....	12
User Interface	13
1. Basics	17
Paper.....	17
Paper Guidelines	17
Creasing	18
About the Crease.....	18
Choose the Correct Creasing Blade Set	19
Replacing Creasing Blade Set	20
Adjusting Crease Depth.....	24
Choose the Correct Blade Set (optional).....	25
Replacing Blade Sets (optional)	26
Adjusting Crease Blade Depth (optional).....	29
Setting Crease Tilt Knob	30
Perforation	32
About Perforation.....	32
Rotary Perforation	33
Rotary Perforation.....	33
Cross Perforation	38
Blade removal / replacement.....	38
Anvil strip removal / replacement.....	41
Perforation depth adjustment procedure	43
Folding.....	44
About the Fold	44
Deflects.....	45
About Deflects	45
2. Setting Up a Job	47
Getting Started.....	47
Job Preparation	48
Paper stack preparation.....	48
Measuring the paper curl	50
Loading Paper	51
Feeder Table Extension (optional)	52
Stacker Settings	53
Stacker Settings Menu	53
Folding Stacker Settings	54
Fold-Off Stacker Settings	55
Belt Stacker Module (optional).....	56

Continued on next page...

The Home Screen	58
Overview	58
Paper Size	59
Pre-set Patterns	61
Custom Job	63
Roller Gap Adjustment	64
Atlas C350 Quick Reference Sheet	65
Saving and Loading Jobs	66
Counters	67
The Tools Screen	68
Overview	68
Feeder Settings	69
Clear Jams	70
Change Crease Blades	71
3. Troubleshooting	73
General	73
Misfeeds / Jams	73
Misfeed / Jam in the Feeder	73
Misfeed / Jam in the Folder	73
Fault Codes	74
List of Fault Codes	74
Accuracy Checks	80
Alignment Calibration Check	80
Separation Pad Check	82
Creaser Calibration Check	83
Fold Calibration Check	84
4. Remarks	87
Do's and Don'ts	87
Where to Put Your Machine	88
Machine Environment	88
Power Connection	88
Access to Machine	89
Recommended Weekly Operator Maintenance	90
Limitations of the Atlas C350	92
5. Specifications	93
Machine Specification	93
General	93
Physical characteristics	93
Paper handling	94

What You Can Do With This Machine



The Atlas C350 is a heavy-duty automatic creasing and folding system designed to complement mid to high volume digital and offset production presses.

The Atlas C350 has the capability to handle the new long formats that the print engines now can produce. It can also be equipped with dual creasing blades allowing up and down creasing in a single pass. The Atlas C350 is built with the easy open design suction feeder, that handles sizes from 210 – 1300mm (8.3” – 51.2”) in length.

As the Atlas C350 creases and folds in one non-stop pass, the precision of fold and crease placements are extremely accurate. Applications such as 6-panel brochures become an easy task even for 8.5”x11” landscape finished formats.

The Atlas C350 comes standard with the patented Creasing Blade installed. This blade allows for creasing without stopping the sheet, giving a top speed of up to 6,000 sph with one crease and fold on an 8½”x11” sheet.

Guide To Components

Atlas C350

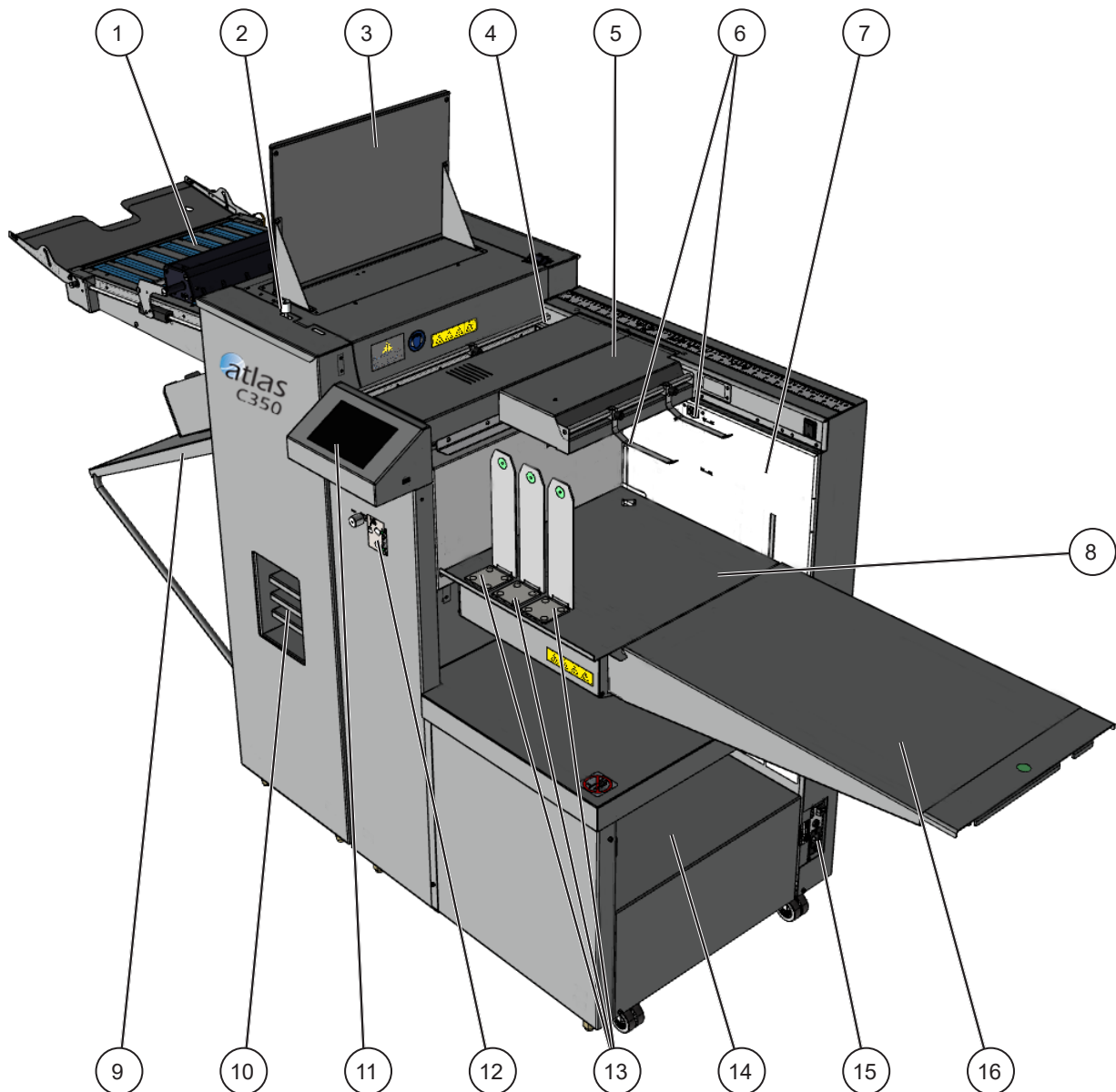

- | | |
|------------------------------|--------------------------------------|
| 1. Outfeed conveyor | 9. Crease only delivery |
| 2. Crease skew adjustment | 10. Storage shelves |
| 3. Top cover | 11. User interface (UI) |
| 4. Registration area | 12. Feeder skew adjustment wheel |
| 5. Vacuum belts (underneath) | 13. Magnetic paper guides |
| 6. Paper guide tongues | 14. Storage shelf |
| 7. Infeed alignment wall | 15. Power inlet and fuse |
| 8. Infeed table | 16. Paper table extension (optional) |

Feeder Module

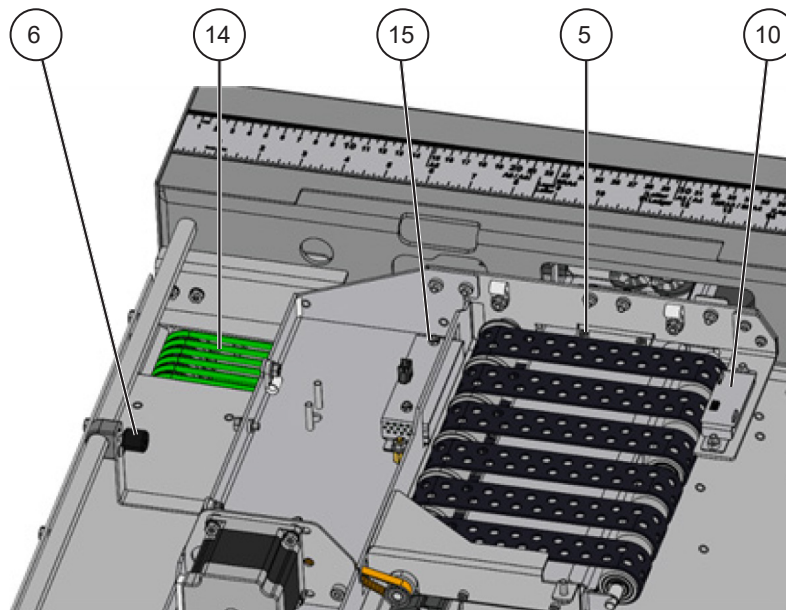
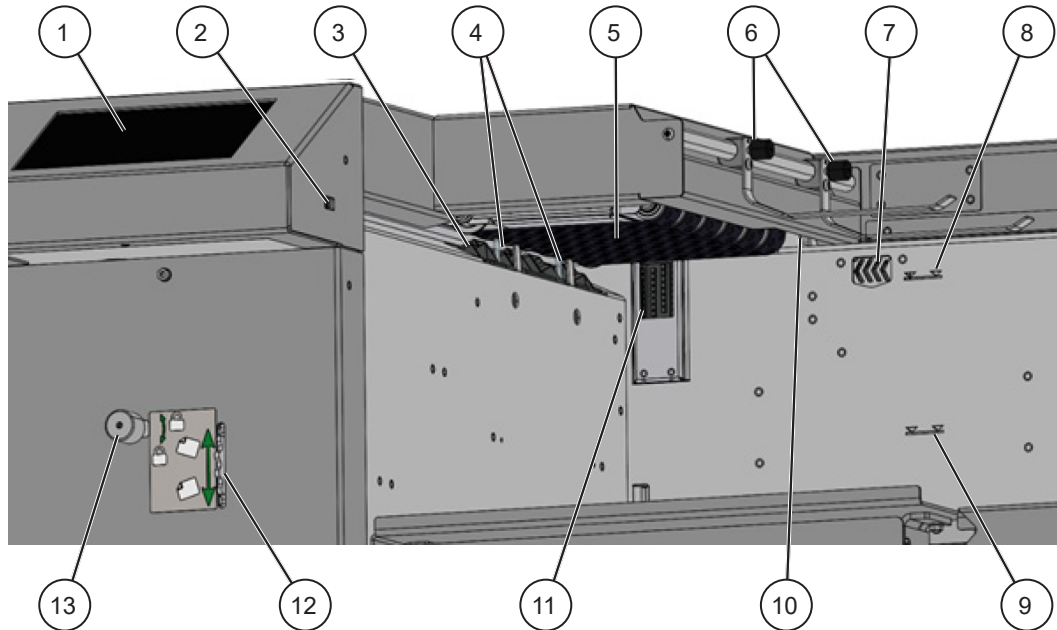

 **NOTE:** Covers removed for clarity.

- | | |
|---|--|
| <ol style="list-style-type: none"> 1. User interface (UI) 2. USB port for software updates 3. Front separation fan 4. Paper separation pads 5. Vacuum belts 6. Paper guide tongues 7. Side float fan 8. Maximum paper stack height for sheets shorter than 700 mm (27.6") | <ol style="list-style-type: none"> 9. Maximum paper stack height for sheets longer than 700 mm (27.6") 10. Paper stack height sensor Q4 11. Separated paper (SP) sensor Q12 12. Feeder skew adjustment wheel 13. Feeder skew adjustment locking knob 14. Registration (alignment) belts 15. Ultrasonic double sheet detector (US DSD) Q10 |
|---|--|

Folding Module

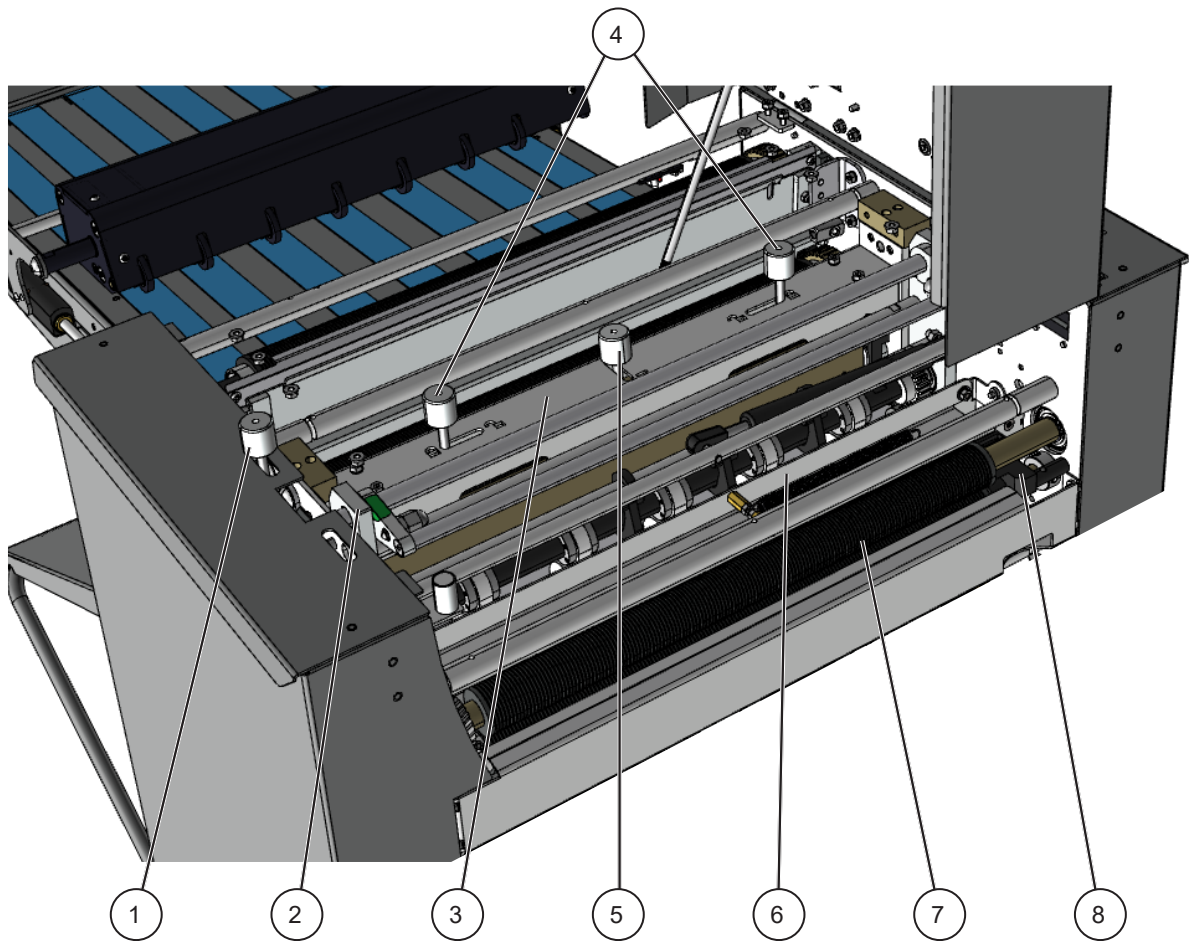

1. Crease skew adjustment
2. Rotary tool carrier
3. Dynamic Crease unit
4. Dynamic Crease pressure lock
5. Dynamic Crease pressure adjustment
6. Paper path – can be replaced with an optional static creaser
7. Input rollers
8. Input sensor

User Interface

The Atlas C350 has a User Interface (UI) which allows for setting up jobs and viewing / modifying machine settings and properties. Detailed descriptions of each menu and sub-menu are found in Section 2 of this Operator Manual.

 **NOTE:**

Depending on modules and features installed, the screen may look different from what you see here. Some functions may be greyed out or not visible at all and remaining buttons will stretch to fit the screen. This manual will most often show a fully configured system.

The control panel is a touchscreen. Point at the screen and press the “button” to reach the desired function or change the desired setting.

The Home screen displays paper and job parameters. The operator can start, edit, pause or abort the job from this screen.



To get started:

1. Load paper on the infeed table and choose the correct paper size by clicking the Media button from the top menu.
2. Choose the desired pre-set by clicking the Pattern button on the Home screen.
3. Press the Play button to start the machine cycle.

Tools and Accessories

The following tools and accessories are included with the Atlas C350

Part number	Description
601-167	Digital thickness gauge
1-99-12	28T rotary perforation blade (7 TPI)
1-99-35	Rotary perforation / slitting anvil
142-115551	Multi-purpose wrench
601-185	Sensor cleaning brush
601-118	Roller cleaning brush

Optional Parts

Several upgrades and optional tools are available to increase the performance of your Atlas C350. Please contact your Dealer for additional information and pricing.

Part number	Description
Upgrade kits:	
AC-150-10	Additional Static Creaser Assembly
Dynamic Crease Blade kits:	
AC-150-60	Dynamic Crease Blade (first station, 1.2 mm)
AC-150-70	Dynamic Narrow Crease Blade (first station, 1.0 mm)
AC-150-80	Dynamic Extra Narrow Crease Blade (first station, 0.7 mm)
Blade kits:	
AC-150-20	Static Crease Blade Kit (second station, 1.2 mm)
AC-150-30	Narrow Static Crease Blade Kit (second station, 1.0 mm)
AC-150-40	Extra Narrow Static Crease Blade Kit (second station, 0.7 mm)
AC-150-50	Full Cross-perforation Kit
Rotary tools:	
AC-75	20T Rotary Perforation Blade (5 TPI)
AC-76	28T Rotary Perforation Blade (7 TPI)
AC-80	Rotary Slitting Blade Set (top and botom)
AC-77	56T Rotary Perforation Blade (14 TPI)
AC-78	96T Rotary Perforation Blade (24 TPI)
AF-20	Light Scoring Wheel
AF-30	Heavy Scoring Wheel

The Atlas C350 is supplied with a single Dynamic Creasing unit. A static creaser can be fitted to this machine. This enables up/down creasing in a single pass and (with the cross-perforation kit) creasing and cross-perforation in a single pass.

Rotary tools allow the Atlas C350 to perforate, slit or score work in the process direction. This machine is supplied with a rotary tool carrier and a single rotary perforation blade (28 teeth, 7 teeth per inch (TPI)). Additional rotary blades as well as scorers are available for purchase.

Page intentionally blank.

1. Basics

Paper

Paper Guidelines

Paper comes in many different makes, types and finishes. There are many ways to print on the paper and then protect that printed image. The grain direction, fiber structure, substrate thickness, porosity, coating type, bond strength of the coating, water content, relative humidity and many other things can affect how the paper will behave when you crease and fold it. We recommend that you learn to identify these differences. Be prepared to make small adjustments to the machine to stop any problems that they might cause.

Guidelines:

- Always make sure that the sheets of paper you use are cut square. This machine is designed to crease the paper at right-angles. It cannot do this if the paper edges are not cut at 90° angles to each other.
- Always make sure that all of the paper for a job is cut the same. This machine uses the sheet length that you set to automatically set the crease positions on a document. The document will not be accurate if the paper length is not set correctly, or if the length of the paper changes during a job.

Creasing

About the Crease

1

A crease stops the paper and printed image of a document from cracking when it is folded. The crease is made when a sheet of paper is compressed between the two parts of a mechanism known as a blade set. The blade set uses an ANVIL and a BLADE to form the crease. A powerful motor operates the blade set so that it can put a large amount of pressure on the paper. This pressure compresses the substrate and printed image, which makes the paper thin and weak along the edges of the crease. This allows the paper to fold accurately along the crease.

The Quick Release Blade Set (optional) can crease and or perforate (optional) sheets accurately at a rate of 8,500 8.5x11" sheets per hour. After creasing, the finished products are collected neatly on a stacking tray.

The Dynamic Crease Blade Set in this system does not need the paper transport system to stop when it makes a crease, which allows this system to process up to 6,500 8.5x11" sheets per hour.

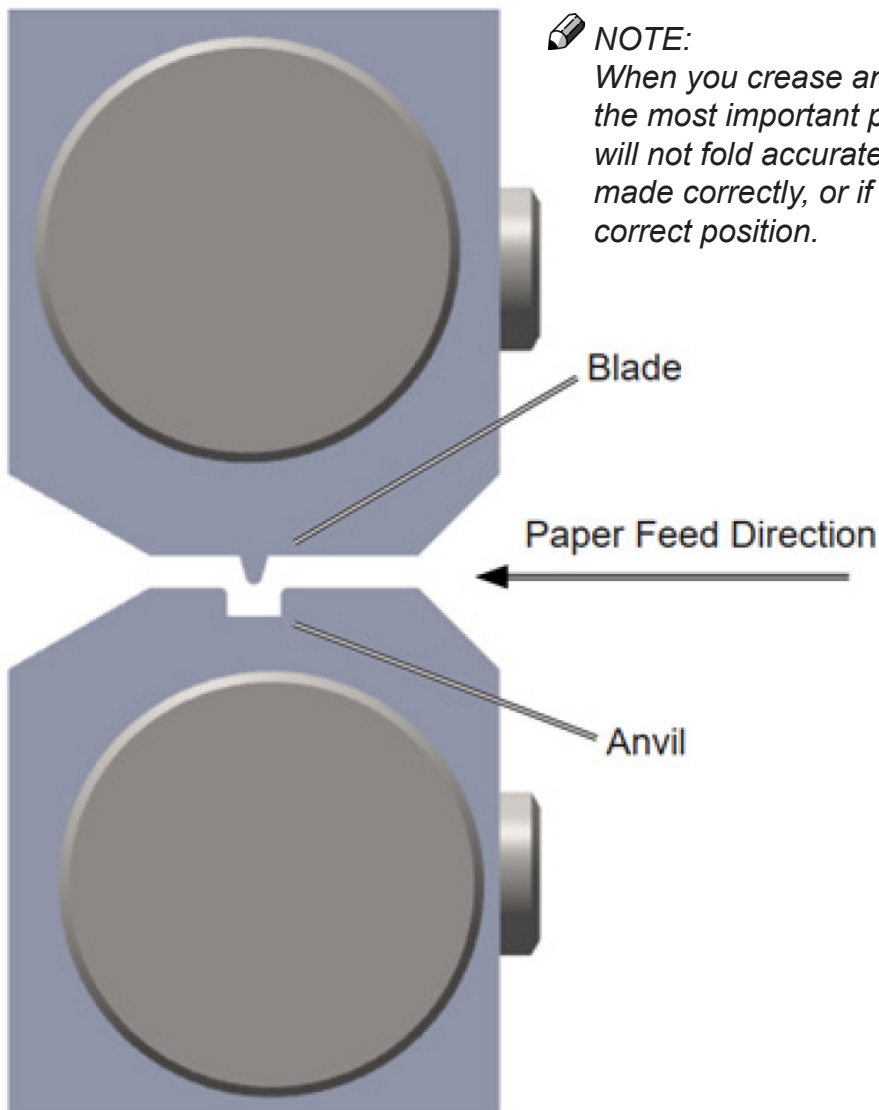

NOTE:
When you crease and fold, the crease is the most important process. The paper will not fold accurately if the crease is not made correctly, or if it is not made in the correct position.

Choose the Correct Dynamic Crease Blade Set

This machine is supplied with a single standard crease blade set. Several optional blade sets are available. Refer to the table below to see which type of blade set is most suitable for your job.

Sheet Thickness	Blade Set	Crease Width
≥ 0.25 mm (≥ 0.010 ")	Standard (supplied with machine) 14200006	1.2 mm (0.051")
≤ 0.25 mm (≤ 0.010 ")	Narrow (optional) 14200007	1.0 mm (0.039")
≤ 0.15 mm (≤ 0.010 ")	Narrow (optional) 14200008	0.7 mm (0.028")

The Standard blade set is designed to give a good crease on thick paper and thin card. To do this, it makes a wide crease. A wide crease is necessary because it gives sufficient material at the spine of the fold.

The Narrow blade set is designed to give a good crease on medium and thin paper. To do this it makes a narrower crease than the Standard blade set does. A narrower crease is necessary because if there is too much material at the spine of the fold, the fold might not be accurate or square.

Always make sure you have the correct blade set installed before starting a job. When running into creasing or folding problems, try a different blade set. This can help solve the problem, even if it is not the usual blade set that is recommended.

Replacing the Dynamic Crease Blade Set

This machine is supplied with a single Standard crease blade set. The blade set can be rotated to produce up or down facing creases without flipping the stack of paper.

1

 **NOTE:**

Optional blade sets to produce narrower crease are available.

To flip the crease blade set or replace it with another set:

1. From the touchscreen interface choose Tools -> Change Crease Blades.

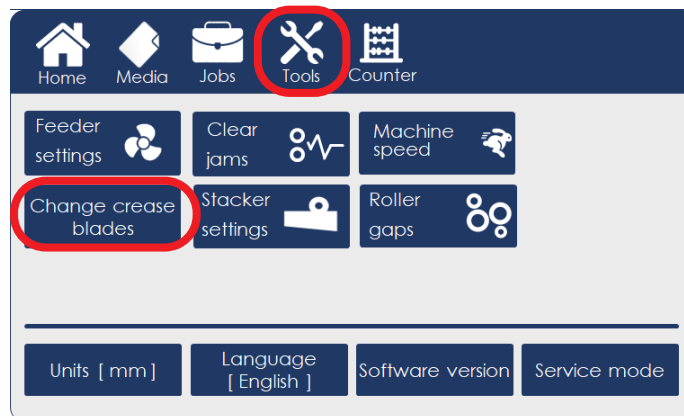

2. Select Move tools to home position.



3. Open the top cover.

Continued on next page...

4. Loosen the locking knobs (in red) in the direction indicated by the arrows [A].

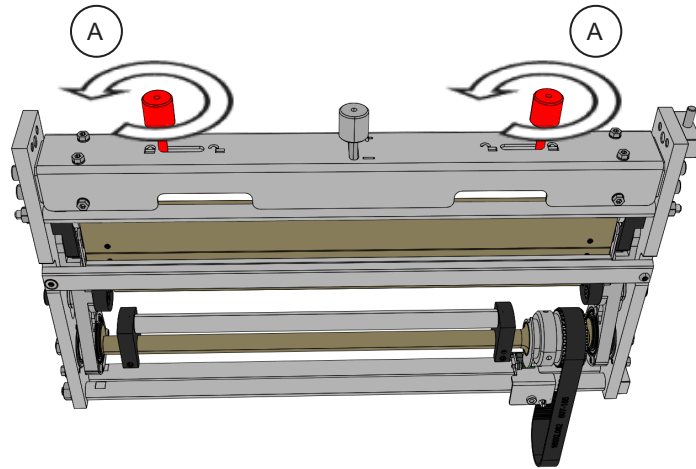

5. Slide the Locking knobs (in red) to the centre [B] to release locking pins.

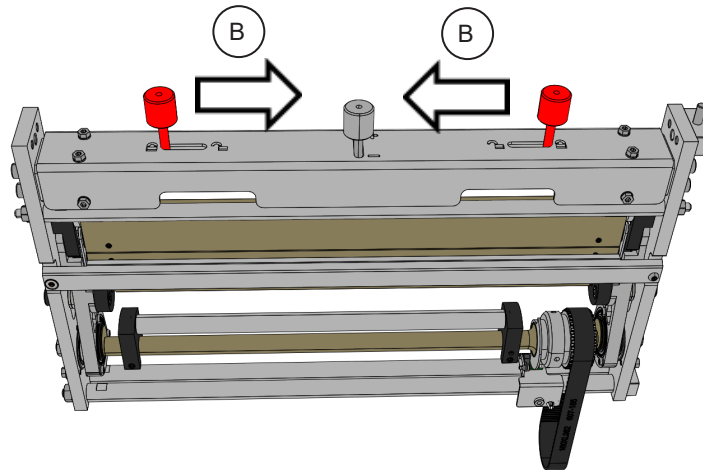

6. Pull the blade set upwards to remove it [C].

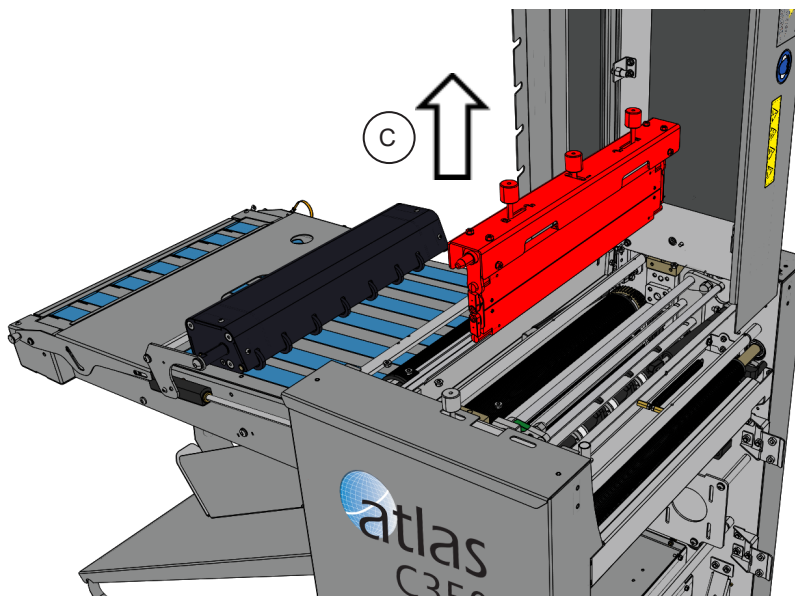

Continued on next page...

7. Push Blade Guide Block [D] to the side and remove Blade Link [E].

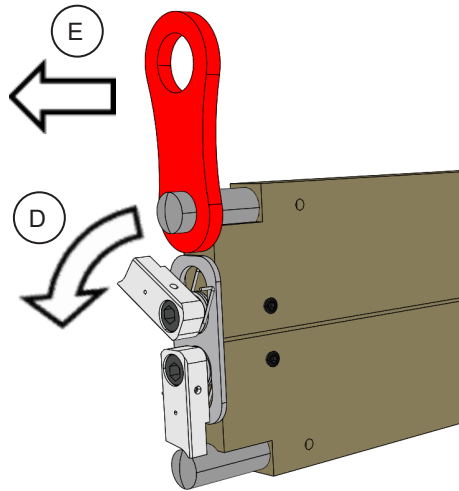

8. Attach Blade Links and Bridge to new blade set and reinsert.

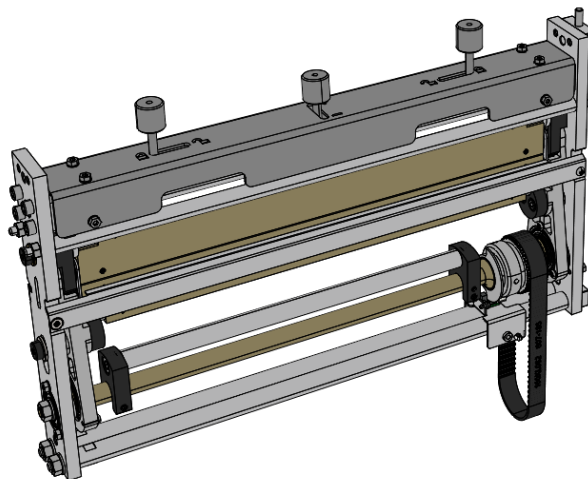

 **NOTE:**

A label on the blade set indicates paper movement direction. Ensure the blade set is installed in the correct direction. Installing the blade backwards may result in poor crease quality and paper jams.

Continued on next page...

9. Close the top cover.

10. From the touchscreen interface choose Tools -> Change Crease Blades.

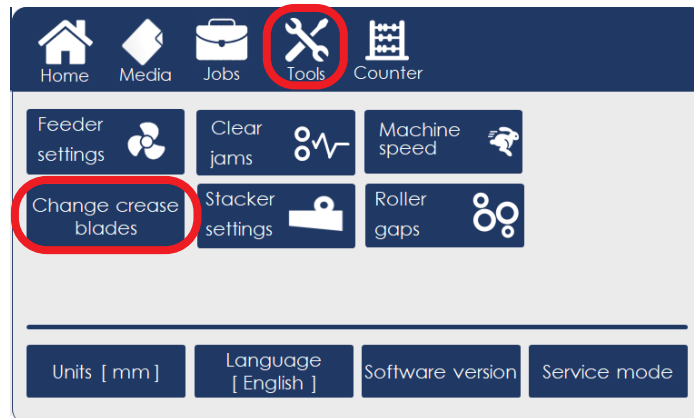

11. Use this menu to choose the blade set that has just been installed and set its direction (crease up or crease down). Click the green check mark to confirm.

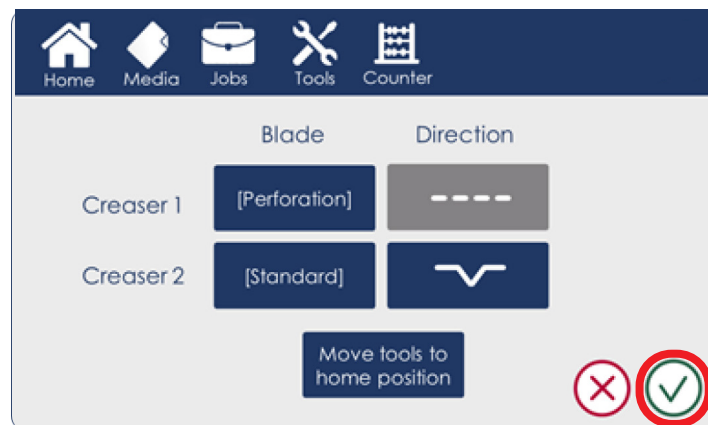

Adjusting Crease Depth DynaCrease

1. Run a proof sheet and inspect the output.

1



2. If the crease is too shallow or too deep loosen the locking knobs.

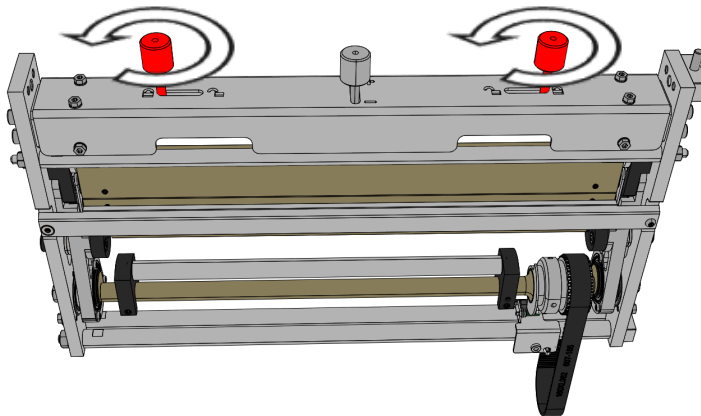

3. Adjust pressure lever on the DynaCrease bridge as shown (A – shallower crease, B – deeper crease).

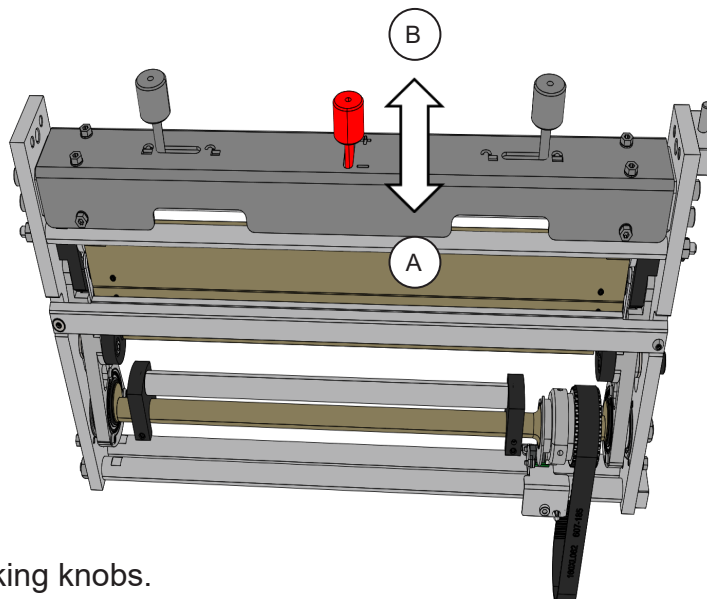

4. Tighten the locking knobs.

Choose the Correct Quick Release Blade Set (optional)

This machine is supplied with a single standard crease blade set. Several optional blade sets are available. Refer to the table below to see which type of blade set is most suitable for your job.

Sheet Thickness	Blade Set	Crease Width
≥ 0.25 mm (≥ 0.010")	Standard (supplied with machine) 14200002	1.3 mm (0.051")
≤ 0.25 mm (≤ 0.010")	Narrow (optional) 14200003	1.0 mm (0.039")
0.09 mm - 0.2 mm (0.0035" - 0.008")	Extra Narrow (optional) 14200004	0.7 mm (0.027")

The Standard blade set is designed to give a good crease on thick paper and thin card. To do this, it makes a wide crease. A wide crease is necessary because it gives sufficient material at the spine of the fold.

The Narrow blade set is designed to give a good crease on medium and thin paper. To do this it makes a narrower crease than the Standard blade set does. A narrower crease is necessary because if there is too much material at the spine of the fold, the fold might not be accurate or square.

An Extra Narrow blade set is also available for purchase. The Extra Narrow blade set is designed to make a very narrow crease. One should use an extra narrow blade set if folding very thin paper (paper thickness close to the minimum specification for this machine).

Always make sure you have the correct blade set installed before starting a job. When running into creasing or folding problems, try a different blade set. This can help solve the problem, even if it is not the usual blade set that is recommended.

Additionally, the crease blade set may be replaced with an optional perforation blade set.

Sheet Thickness	Blade Set	Perforation
0.09 mm - 0.4 mm (0.0035" - 0.016")	Cross-perforation (optional) 14200005	Coarse (7 TPI) or fine (14 TPI) teeth. Full cross perforation or partial cross perforation

 **NOTE:**

For blade set replacement instructions, see the "Replacing Quick Release Blade Sets" section within this manual.

Replacing Quick Release Blade Sets (optional)

This upgrade kit is supplied with a single Standard crease blade set. The blade set can be rotated to produce up or down facing creases without flipping the stack of paper.

1

 **NOTE:**

Optional blade sets to produce narrower creases or to cross perforate are available (see the “Choose the Correct Quick Release Blade Set” section within this manual).

To flip the crease blade set or replace it with another set:

1. Open the top cover.
2. Push down the Bridge Assembly (in red) in the spot indicated by the arrow [A] to unhook it.

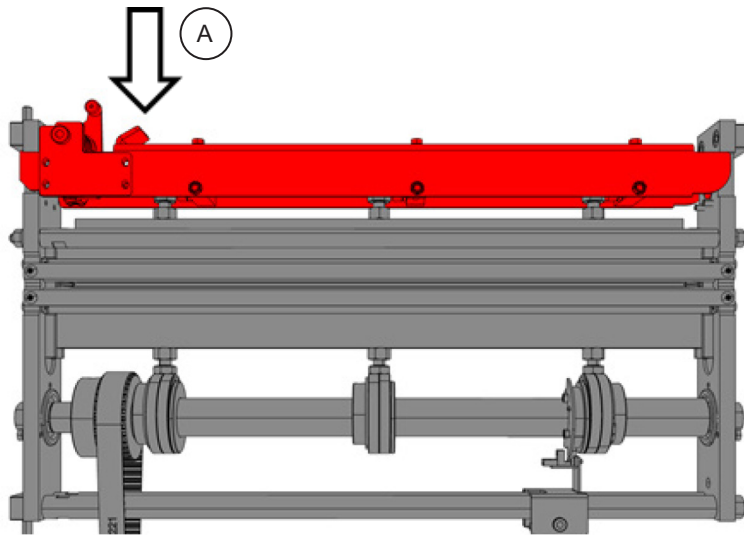

3. While pushing down, pull the Bridge Assembly towards the operator side [B].

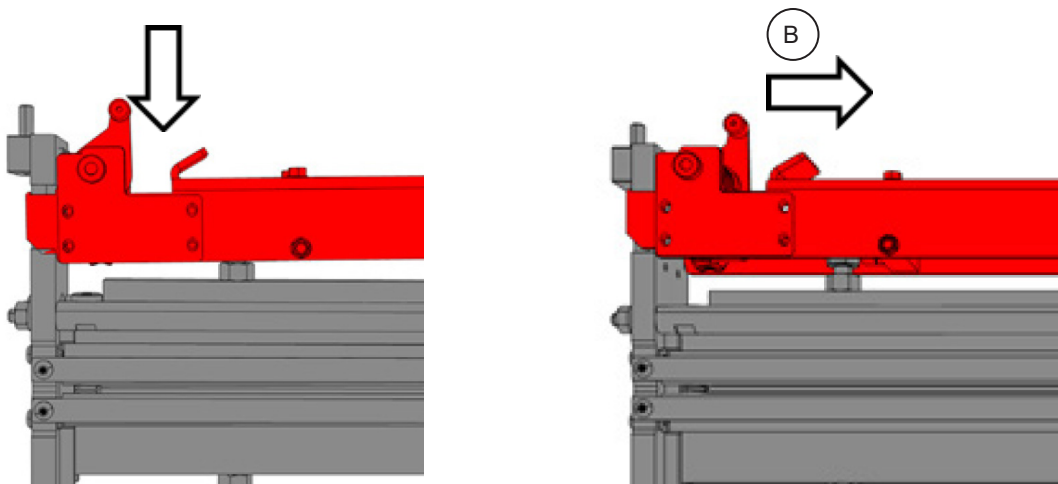

Continued on next page...

- Lift the Bridge Assembly up and remove it.

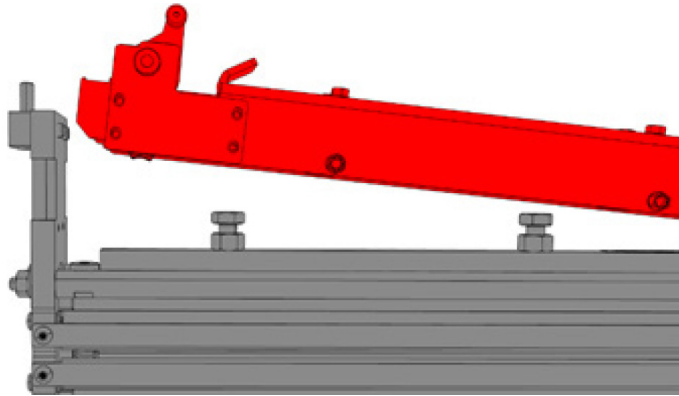

- Pull the blade set upwards to remove it.

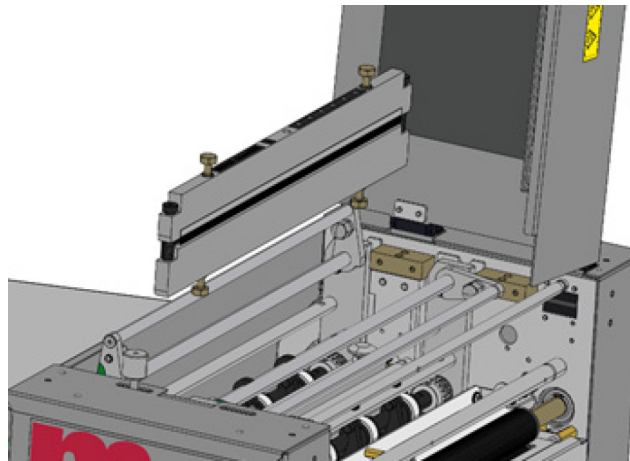

- Insert the new blade set.

 **NOTE:**

A label on the blade set indicates paper movement direction. Ensure the blade set is installed in the correct direction. Installing the blade backwards may result in poor crease quality and paper jams.

- Reinstall the bridge assembly and ensure it locks into place.

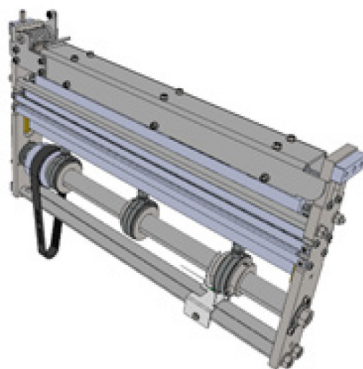

- Close the top cover.

Continued on next page...

9. From the touchscreen interface choose Tools -> Change Crease Blades.

1

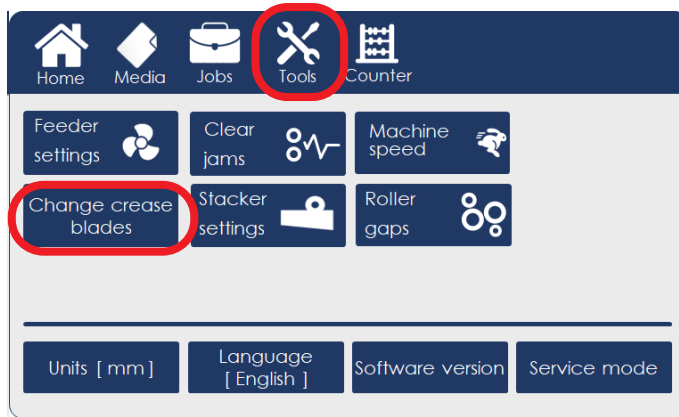

10. Use this menu to choose the blade set that has just been installed and set its direction (crease up or crease down). Click the green check mark to confirm.



Adjusting Crease Depth Quick Release Blade (optional)

1. Run a proof sheet and inspect the output.

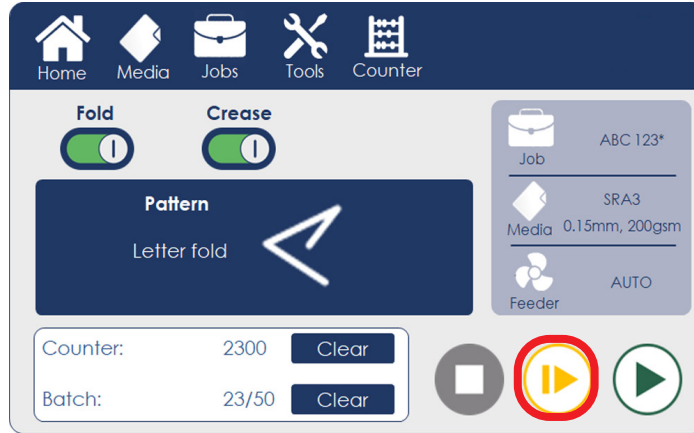

1

2. If the crease is too shallow or too deep use the adjustment lever on the Quick Release Blade bridge as shown (A – shallower crease, B – deeper crease).

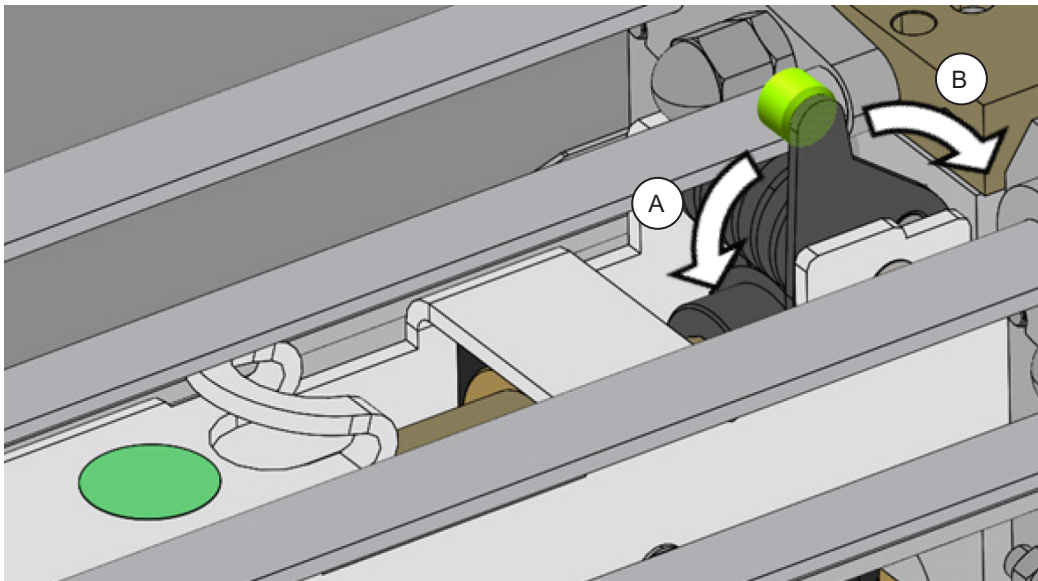

Setting Crease Tilt Knob

1. Run a proof sheet with a single crease and inspect the output.

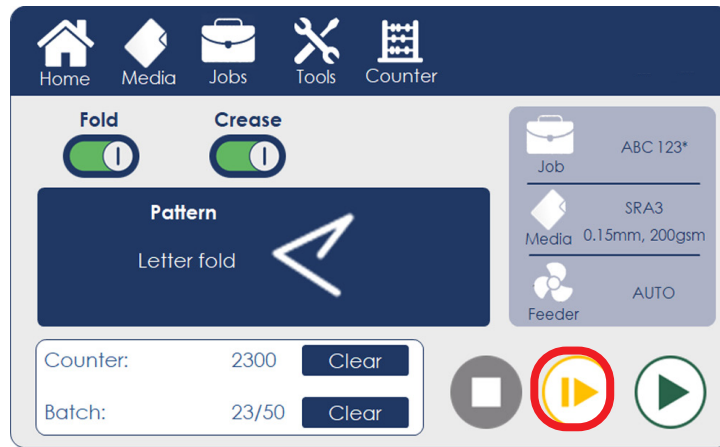

2. If the crease is skewed, adjustment is necessary.

NOTE:

Wrong crease positions are marked in red, correct crease position is marked in green.

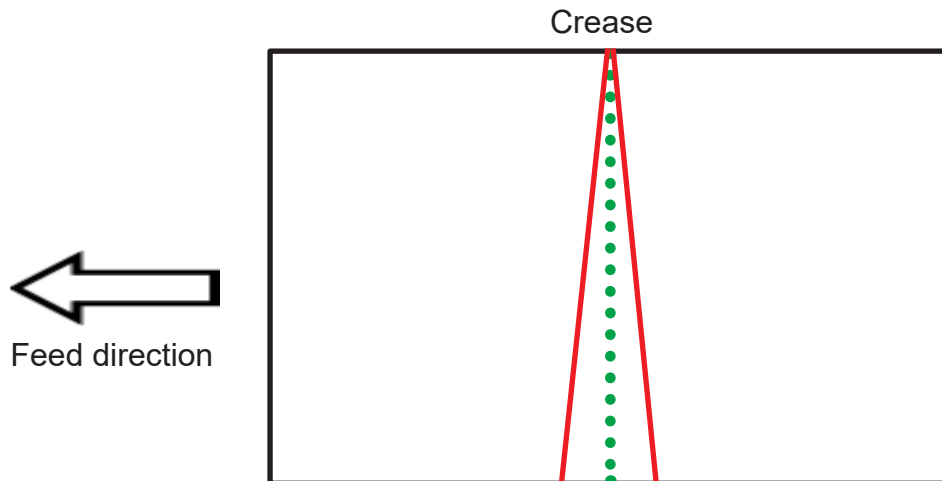

3. To adjust crease skew, loosen the crease adjustment knob by rotating it counterclockwise.

NOTE:

In the below image the optional additional static creaser is shown.

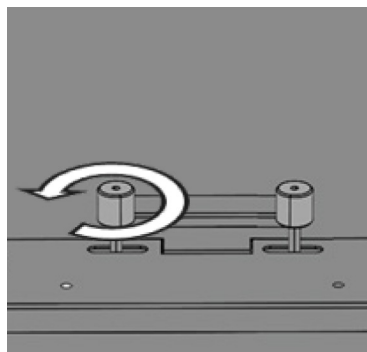

Continued on next page...

-
4. Move the knob slightly, either to the left or to the right depending on the direction of the crease skew.

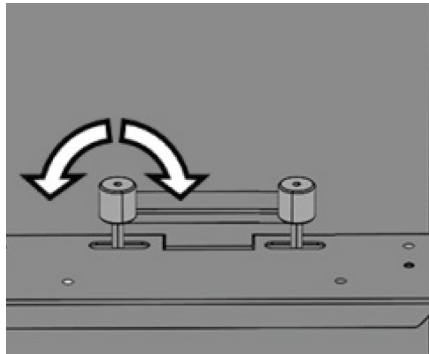

1

5. Rotate the knob clockwise to secure it.
6. Run another proof sheet to check if the crease is now perpendicular to sheet edge.
Repeat steps 2 to 5 if necessary.

Perforation

About Perforation

1

A perforation is a series of cuts in the paper that allows it to be easily and neatly separated into two or more pieces. Perforation can be used to create coupons, tickets, return slips and other products.

The Atlas C350 can perforate sheets in two perpendicular directions:

- In the process direction using rotary tools
- Across the process direction using the optional cross-perforation kit

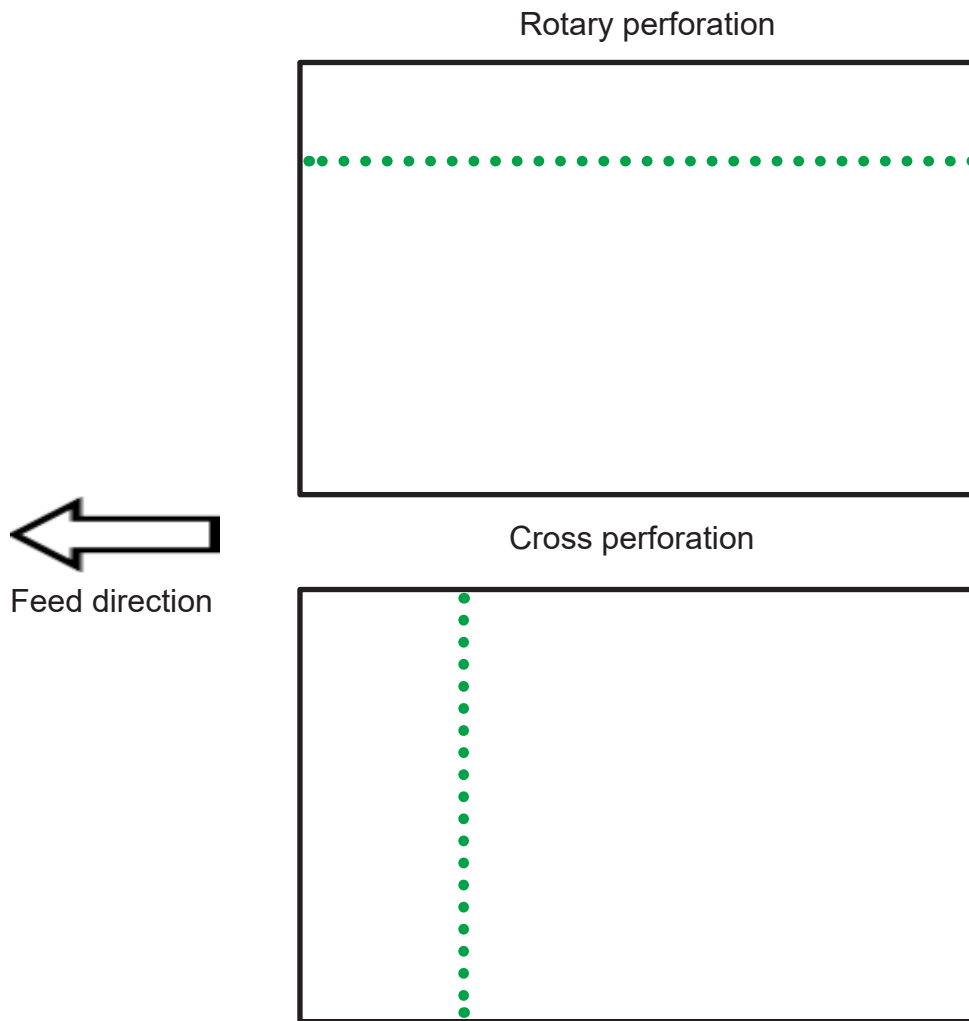

Depending on paper type and the desired finish several different perforation types are available with varying number of teeth per inch (TPI):

5 TPI, 0.8 mm (0.031") tie width – rotary 20T

7 TPI, 0.8 mm (0.031") tie width – rotary 28T – cross-perforation "coarse"

14 TPI, 0.8 mm (0.031") tie width – rotary 56T – cross-perforation "fine"

24 TPI, 0.8 mm (0.031") tie width – rotary 96T

Rotary Perforation

Rotary Perforation

The rotary perforation process uses circular blades mounted on the rotary tool carrier to perforate sheets in the process direction.

 **NOTE:**

1. *Perforation and creasing can be carried out simultaneously. However, if any skew adjustment is made to the feeder in order to compensate for the perforation line being “out of square”, this may affect the accuracy of the crease. If this occurs adjust crease skew separately (see “Setting Crease Tilt Knob” section of this manual).*
2. *By adjusting the outfeed drive tires relative to the drive hubs it is possible to steer the sheet, (i.e. by placing the tire on top of the hub on one side of the paper only).*



To set up rotary perforation a perforation blade and an opposing hardened anvil is necessary. This machine comes with a single perforation blade and an anvil. The perforation blades and anvils are split into two matching halves and are fitted to the drive wheels using the four screws supplied. Do not mix the matching pairs of blades or anvils as this will result in poor perforation.

 **WARNING!**

The circular blades are very sharp. Handle with care.

Setting up rotary perforation

1. Open the top cover.
2. Remove the rotary tool carrier.

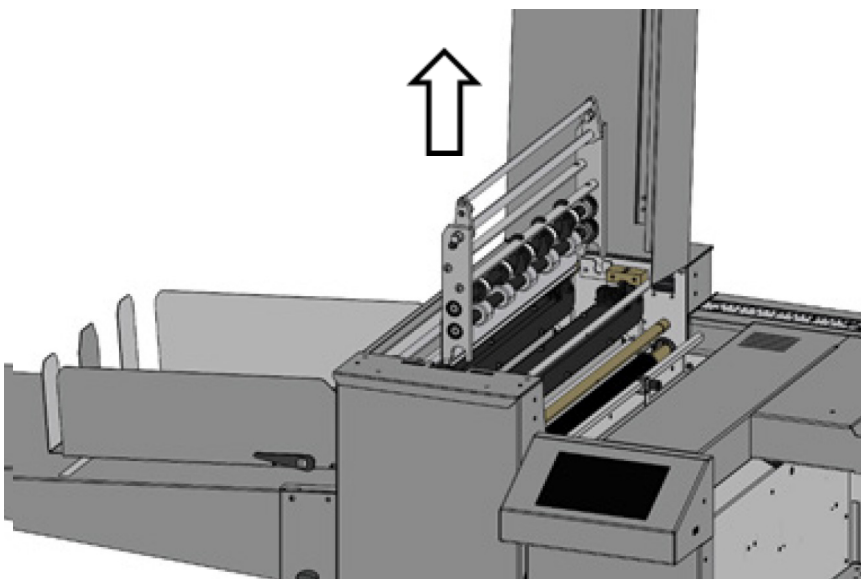

Continued on next page...

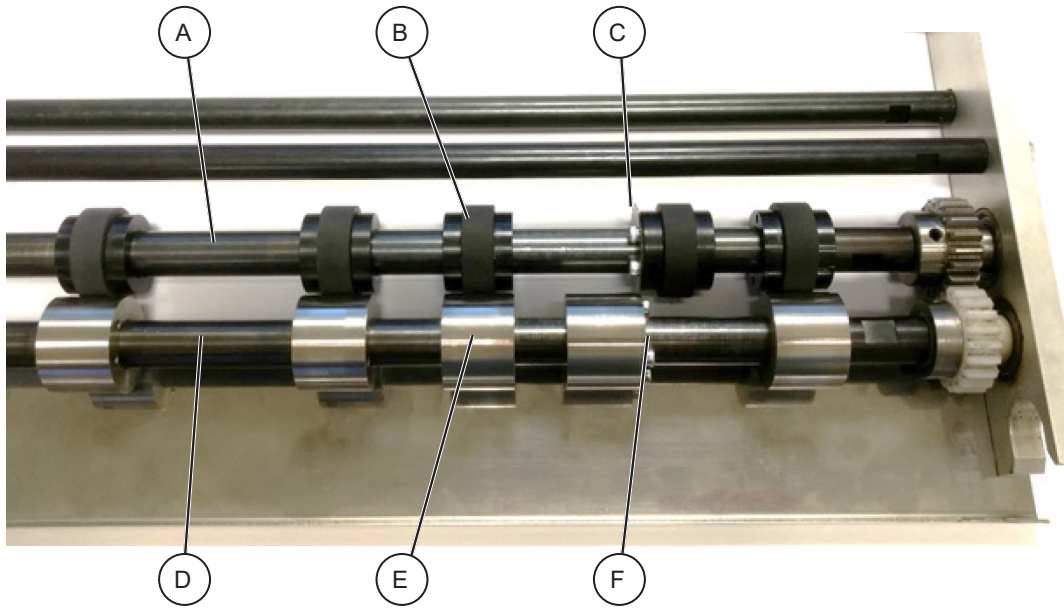

A - Top shaft
 B - Drive wheel
 C - Perforation blade

D - Bottom shaft
 E - Drive hub
 F - Anvil



NOTE:

Up to 5 rotary blades can be mounted on the rotary tool carrier.

3. Using a 2 mm hex key loosen one of the drive wheels [B] and slide it away from any obstructing drive wheels or hubs in order to mount the blade.

4. Mount a matching pair of blades [C] and secure them to the drive wheel using a 2.5 mm hex key.

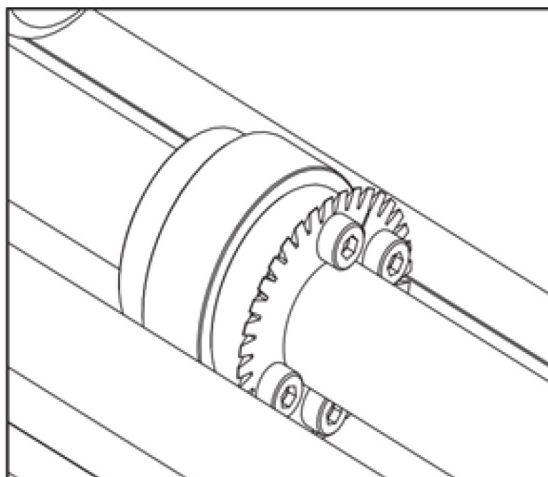

5. Using a 2 mm hex key loosen one of the drive hubs [E] and slide it away from any obstructing drive wheels or hubs in order to mount the anvil.

Continued on next page...

6. Mount a matching pair of anvils [F] and secure them to the drive wheel using a 2.5 mm hex key

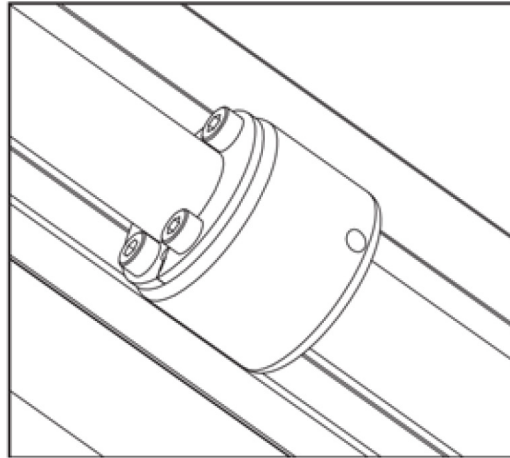

7. Position the perforation blade [C] using the ruler on the rotary tool carrier. Secure the drive wheel in place using a 2 mm hex key.

8. Slide the drive hub with the anvil [F] towards the perforation blade until there is a small clearance (~ 0.1 mm / 0.004") and secure it in place using a 2 mm hex key.

 **NOTE:**

Use an 80 gsm sheet of paper to set the 0.1 mm (0.004") gap between the blade and the anvil.

Do not force the blade against the anvil to prevent damage.

9. Place the rotary tool carrier back in the machine and close the top cover.

10. Run a proof sheet and inspect the output.



11. If position adjustment is necessary, repeat steps 7 to 10.

12. If the perforation is skewed on the sheet ($L1 \neq L2$) use the feeder skew adjustment to correct for this (steps 13 to 16 on the next page).

 **NOTE:**

Changing feeder skew also affects the crease. See "Setting Crease Tilt Knob" section of this manual to adjust this.

Continued on next page...

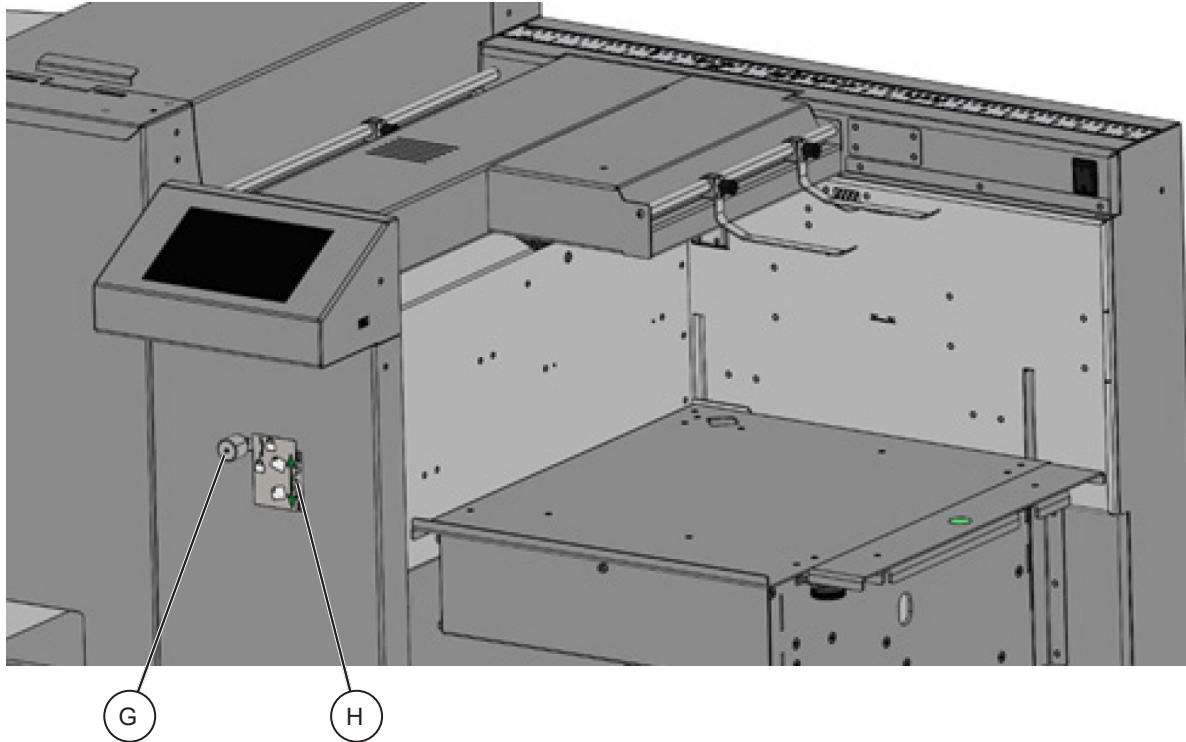

13. Loosen locking knob G by rotating it counterclockwise.
14. Use the adjustment wheel H to set paper registration wall angle. If the sheet skews away from the operator ($L1 > L2$) turn the wheel down. If the sheet skews towards the operator ($L1 < L2$) turn the wheel up.
15. Lock the adjustment wheel by rotating knob G clockwise.
16. Set the sheets on the paper table in the corner and adjust magnetic paper guides if necessary.
17. Run a proof sheet and inspect the output. If further adjustment is necessary, repeat steps 13 to 16.

 **NOTE:**

When not in use, the rotary perforation can be disengaged by sliding either the blade or the anvil to one side so that there is at least a 5 mm (0.2") gap between them. However, it is recommended to remove the blades and anvils completely to avoid unwanted marking on delicate media.

For optional perforation blades see "Optional Parts" in this manual.

Page intentionally blank.

Cross Perforation

Blade removal / replacement

⚠ WARNING!

All blades are very sharp: use extreme caution. Leather gloves must be worn whenever handling the blades.

1

1. Locate the Allen tools supplied with the Cross Perforation kit.
2. Place the cross perforation tool on a table in the orientation shown below.
3. Remove one guide bolt [C] and spring [D]. Only one side needs to be removed.

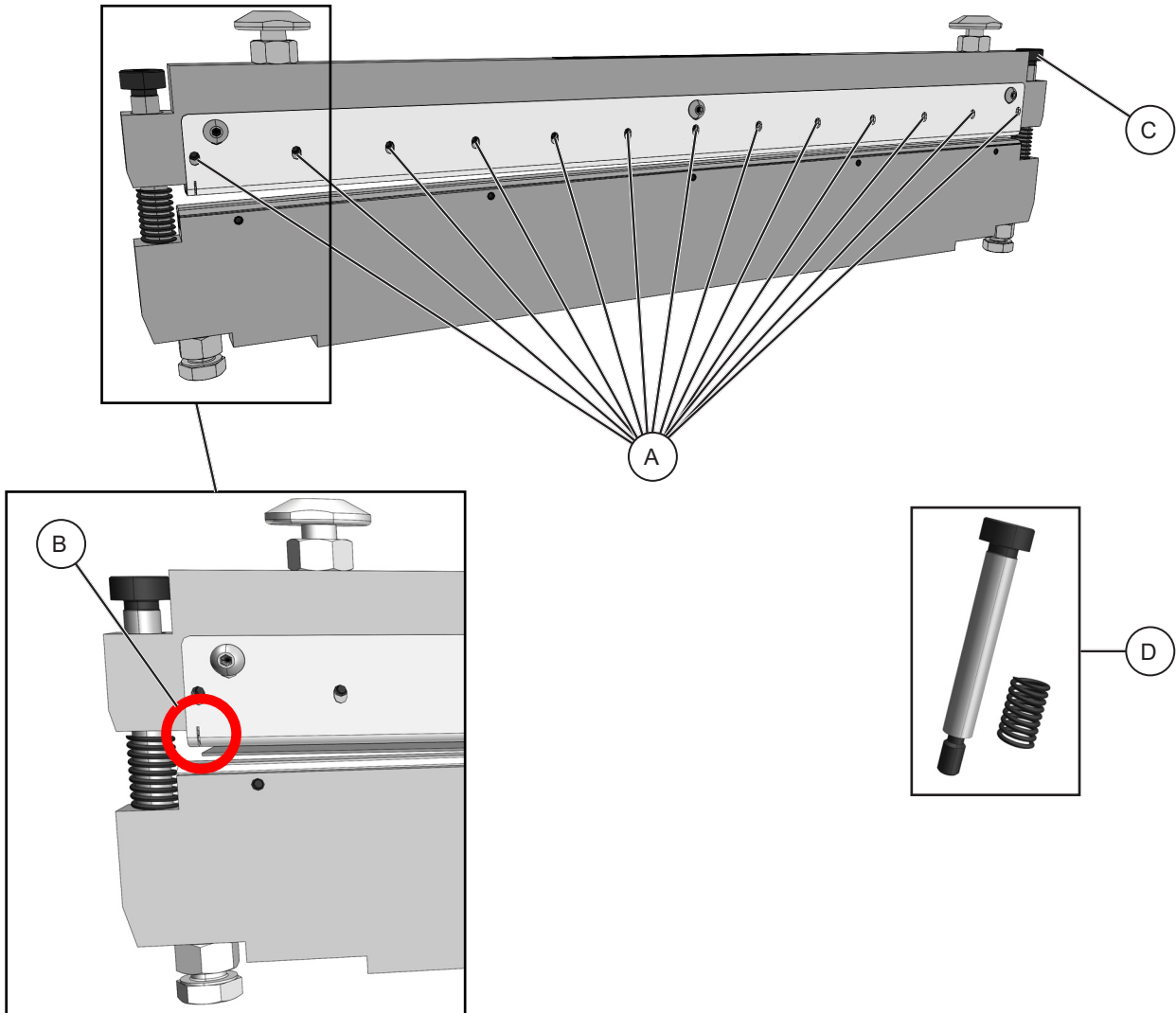

4. Rotate the bottom assembly 180° from the top assembly as shown below.

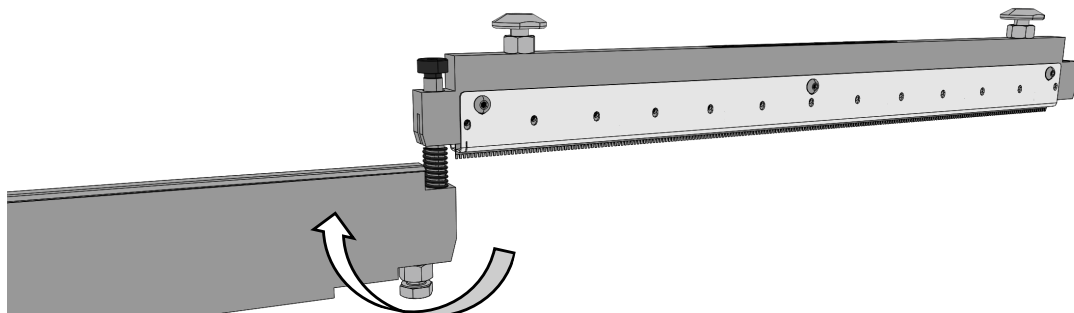

Continued on next page...

⚠ WARNING!

All blades are very sharp: use extreme caution. Leather gloves must be worn whenever handling the blades.

5. Loosen grub screws [A] (x13). Shown on previous page.
6. Lift out the Blade [E].

1

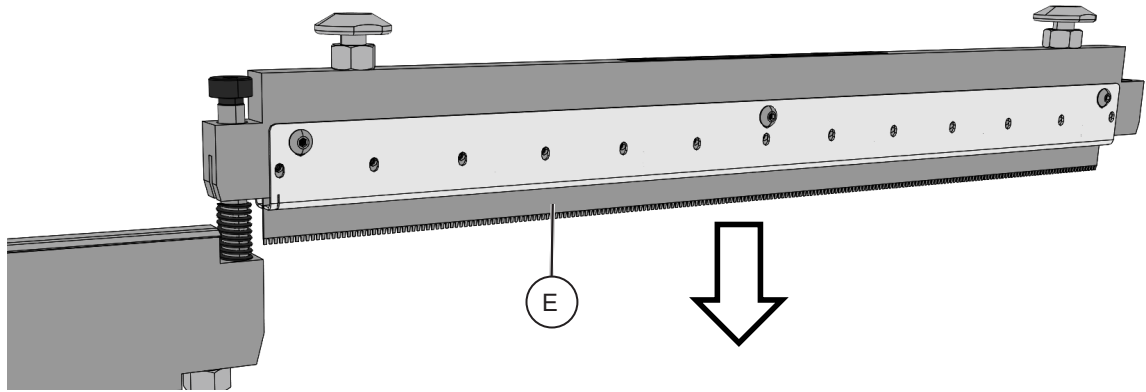

7. Replace with required blade.

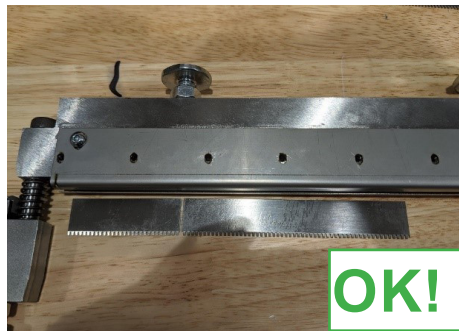
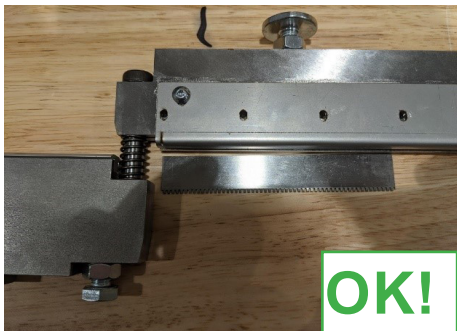

Double stacking is NOT supported.

Continued on next page...

⚠ WARNING!

All blades are very sharp: use extreme caution. Leather gloves must be worn whenever handling the blades.

1

8. Insert the blade into the blade channel.
9. Ensure the blade is fully inserted and does not exceed the notch [B]. *Shown on previous page.*

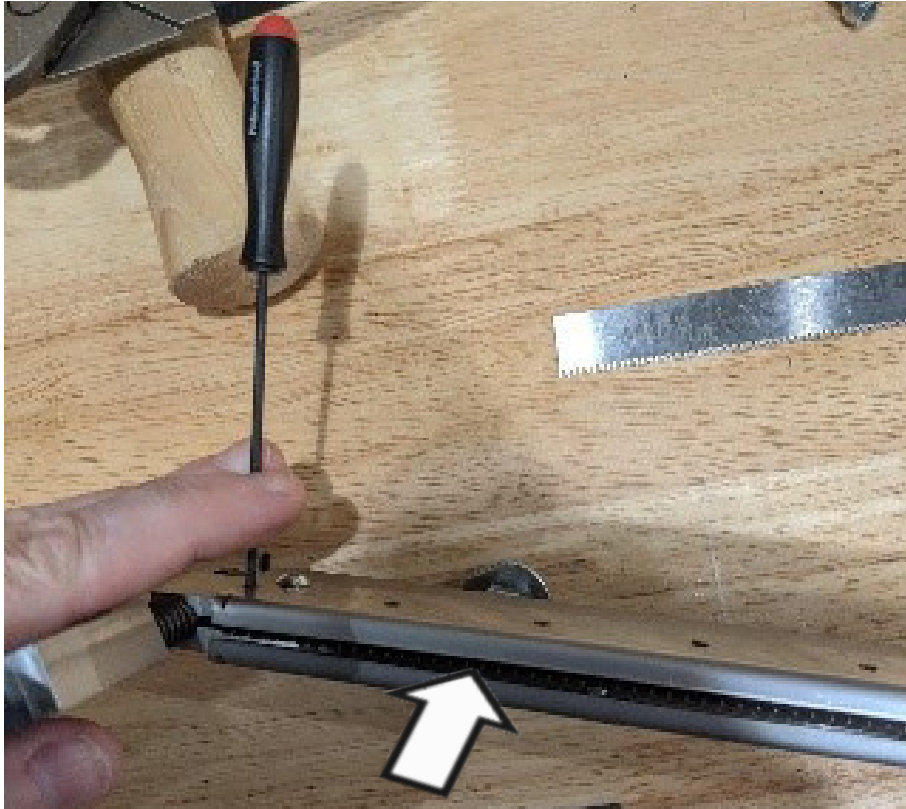

10. Tighten grub screws [A] (x13).
11. Rotate the bottom assembly 180° back into line with the top assembly.
12. Replace bolt [C] and spring [D] and tighten.

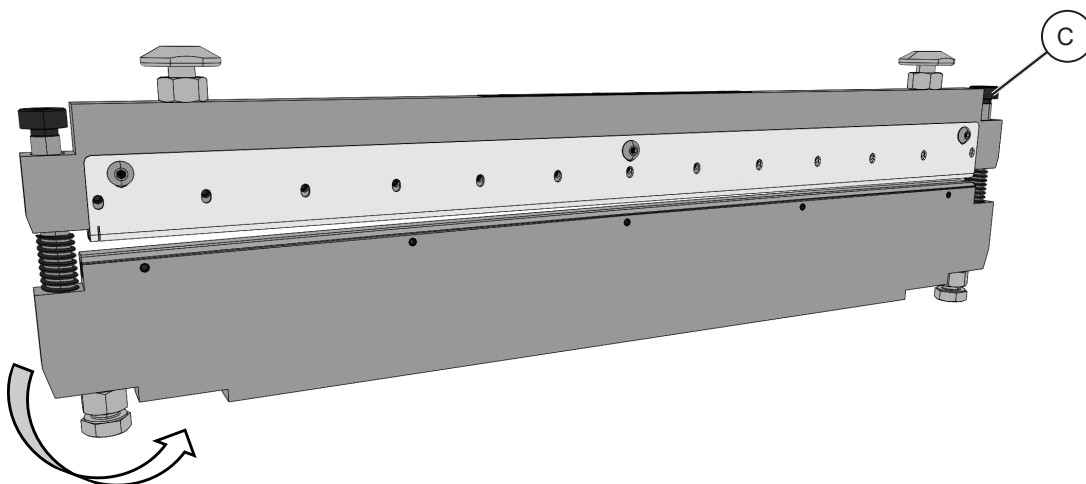

Anvil strip removal / replacement

⚠ WARNING!

All blades are **very sharp**: use extreme caution. Leather gloves must be worn whenever handling the blades.

📌 NOTE:

Before replacing anvil strip decrease perforation depth to avoid causing excess strain on motor and reducing lifespan of anvil strip. adjustment procedure can be found under 'perforation depth adjustment'.

1. Locate the Allen tools supplied with the Cross Perforation kit.
2. Place the cross perforation tool on a table in the orientation shown below.
3. Remove one guide bolt [C] and spring [D]. Only one side needs to be removed.

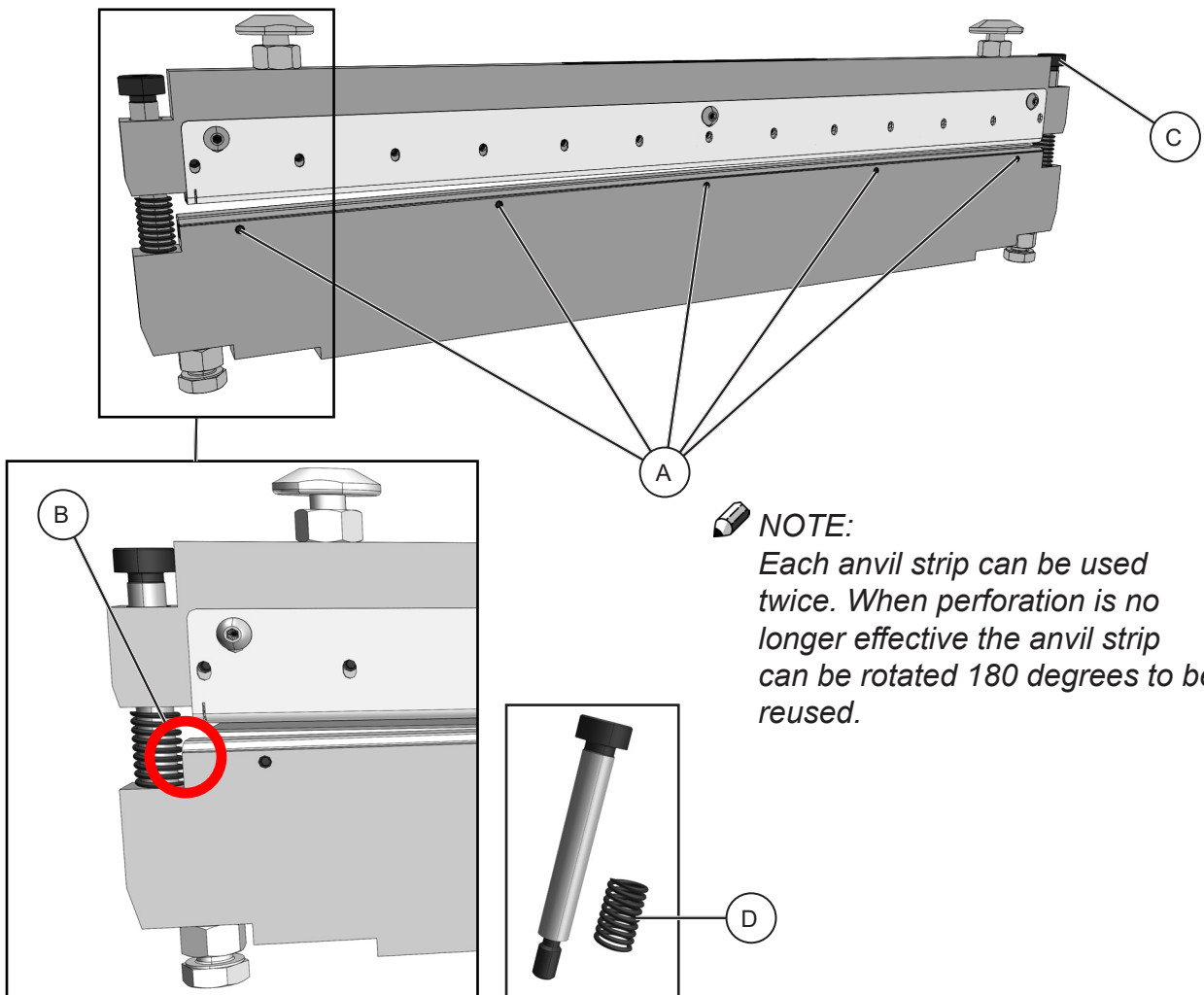

Continued on next page...

⚠ **WARNING!**

All blades are very sharp: use extreme caution. Leather gloves must be worn whenever handling the blades.

4. Rotate the bottom assembly 180° from the top assembly as shown below.

1

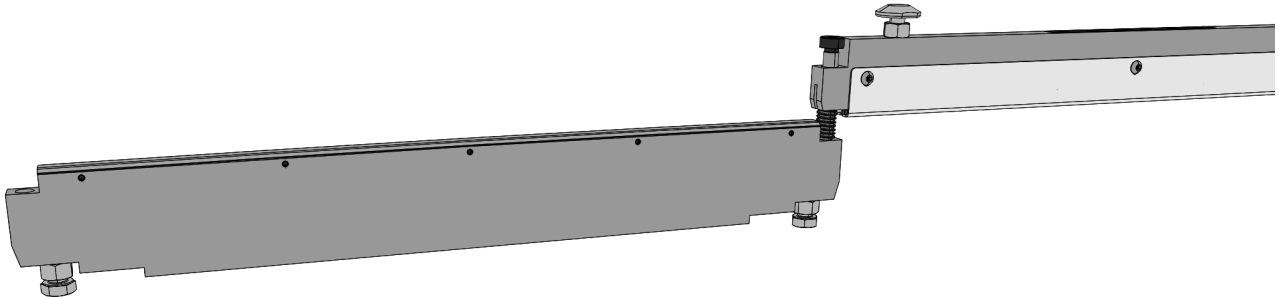

5. Loosen grub screws [A] (x5). *Shown on previous page.*
6. Lift out the anvil strip [E].
7. Rotate anvil strip 180°. **Or.** Replace with spare.

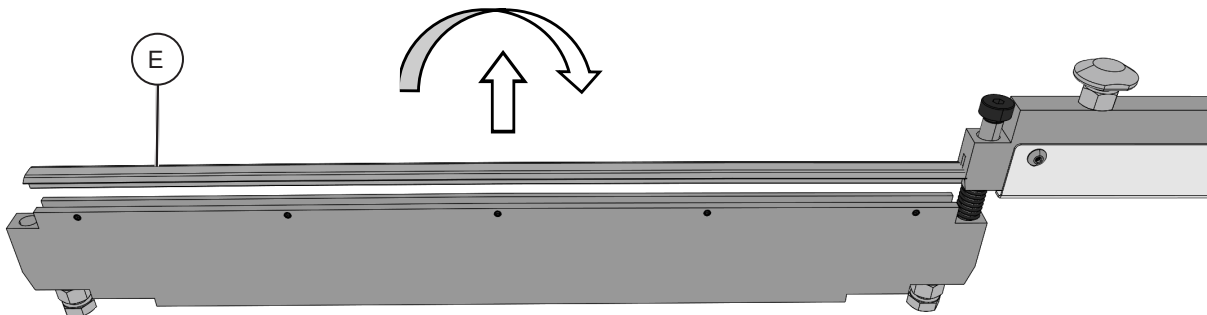

8. Insert the anvil strip into the anvil channel.
9. Ensure the anvil strip is fully inserted and aligned with the edge of the anvil [B]. *Shown on previous page.*
10. Tighten grub screws [A] (x5).
11. Rotate the bottom assembly 180° back into line with the top assembly.
12. Replace bolt [C] and spring [D] and tighten.

Perforation depth adjustment procedure

⚠ WARNING!

All blades are **very sharp**: use extreme caution. Leather gloves must be worn whenever handling the blades.

🔧 NOTE:

Before adjusting depth of perforation ensure the anvil strip does not require replacement.

1. Locate the tools supplied with the Cross Perforation kit.
2. Place the cross perforation tool on a table in the orientation shown below.
3. Adjust [A] (bolt [B] & nut [C]) to increase or decrease depth of perforation.

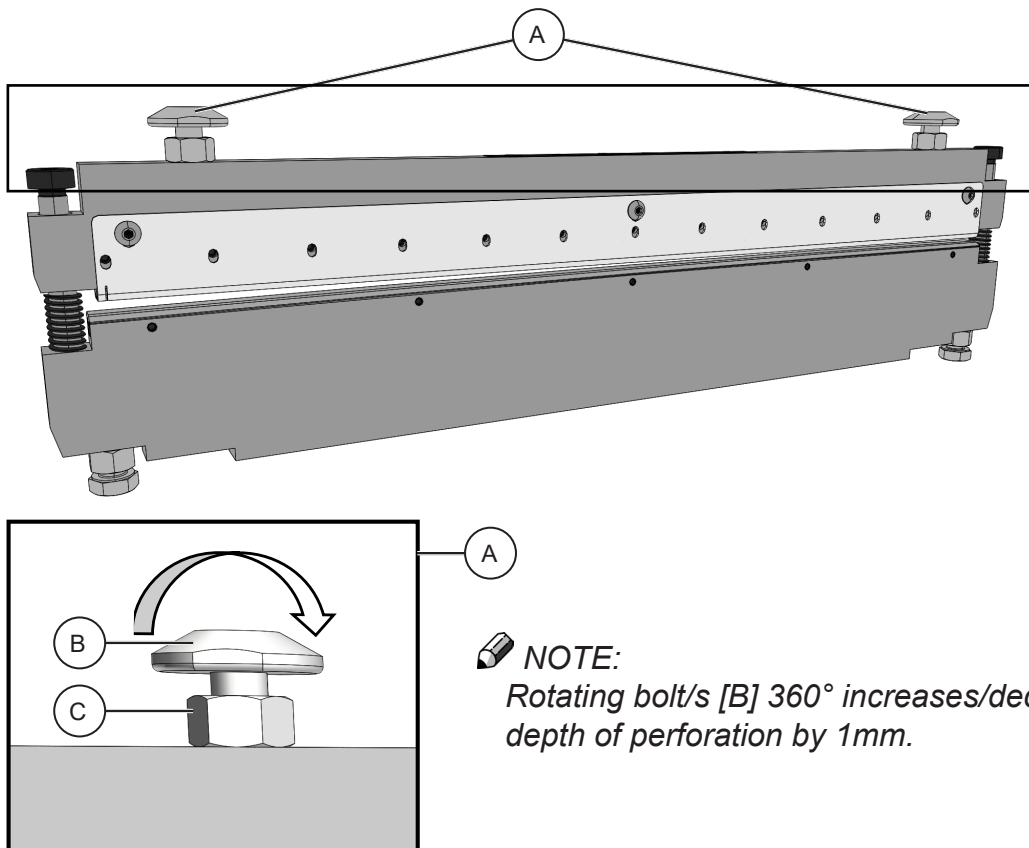

Rotating bolt/s [B] 360° increases/decreases depth of perforation by 1mm.

4. Turn nut(s) [C] anti-clockwise to unlock.
5. Rotate bolt(s) [B] 90° anti-clockwise to increase perforation depth. **Or.** Rotate bolt(s) [B] 90° clockwise to decrease perforation depth.
6. Hold bolt(s) [B] in position and turn nut(s) [C] clockwise to lock.

Folding

About the Fold

1

A fold is made when a sheet of paper is pushed through a pair of fold rollers by a fold-knife. This is known as a right-angle fold because the fold is made 90° to the direction of sheet travel. The machine has two fold-knives and can make up to two parallel folds on each sheet. A cross sectional view of the fold mechanism is shown below.

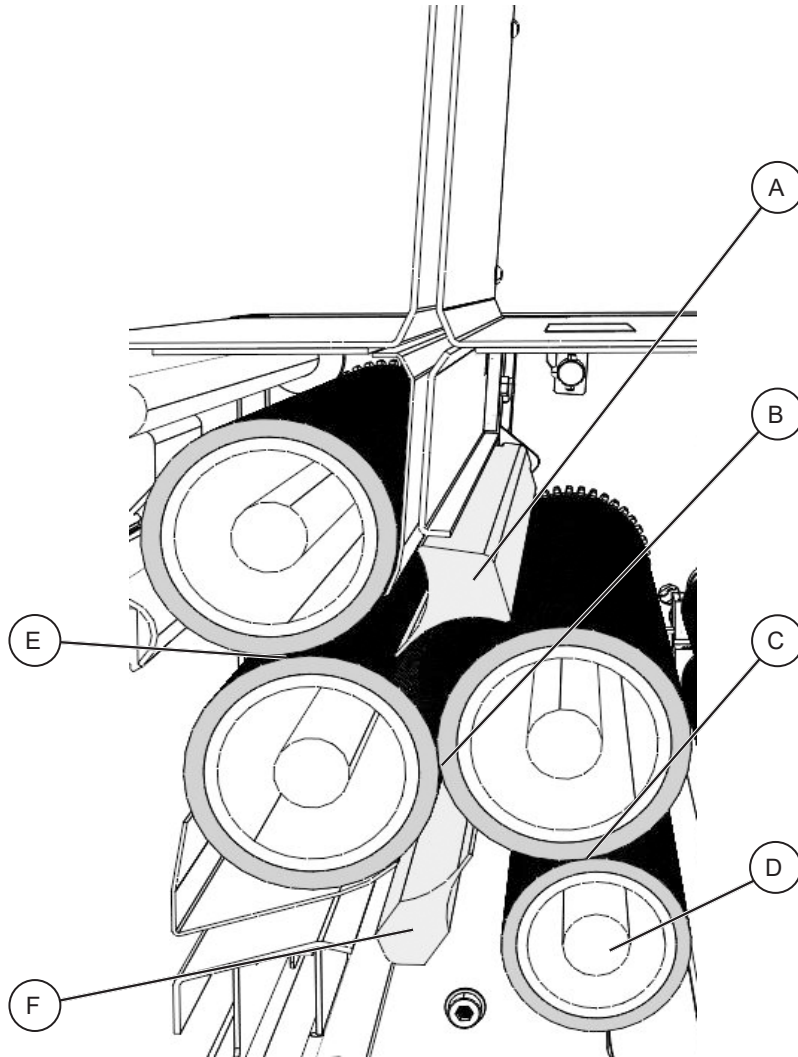

Element	Description
A	2nd Fold Knife (K2)
B	Roller Gap 2
C	Roller Gap 1
D	Fixed Roller
E	Roller Gap 3
F	1st Fold Knife (K1)

This machine has many different fold configurations available. The fold configurations are shown in detail in the “Atlas C350 Quick Reference Sheet” in Section 2 of this manual.

Deflects

About Deflects

The Flying Knife folding system has a unique function that lets the machine pass flat sheets through the fold rollers. This operation is known as a deflect. When you choose to do a half fold on K1 or K2, the fold knife that is not used to fold the document becomes a deflector. This means that the machine aligns the fold knife with the lead-edge or spine of the document to guide it through the machine.

A Half Fold K1 cycle means K1 folds the paper and K2 deflects the paper. This leads to a round spine finish. This cycle is shown below.

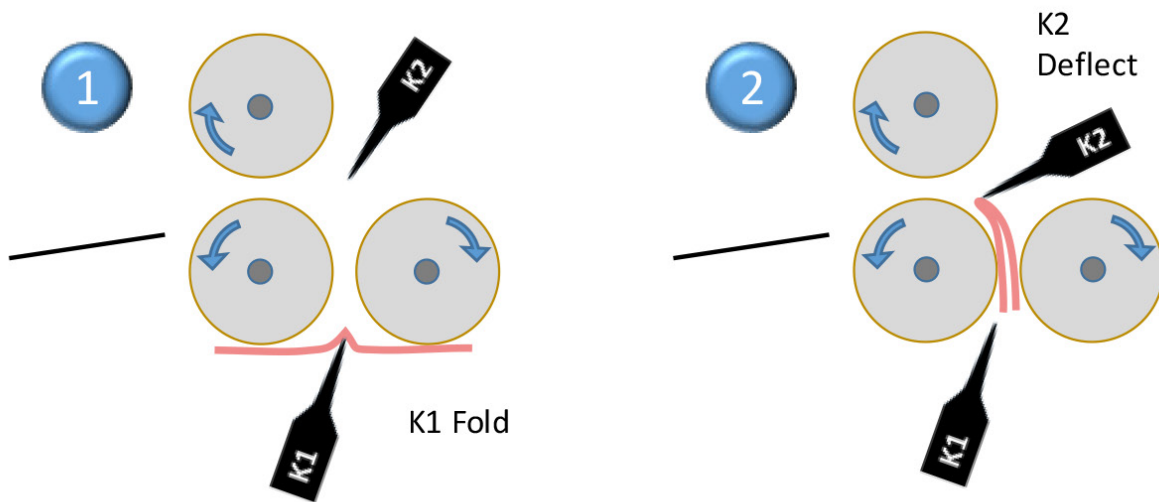

A Half Fold K2 cycle means K1 deflects the paper and K2 folds the paper. This leads to a square spine finish. This cycle is shown below.

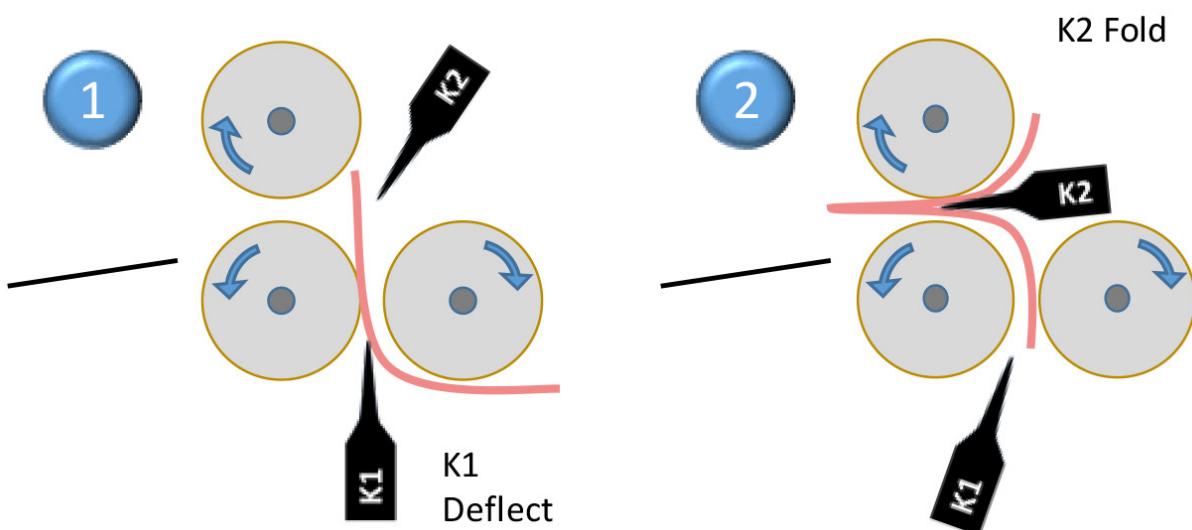

Page intentionally blank.

2. Setting Up a Job

Getting Started

Turning the Machine On/Off

1. Ensure the main power cord is plugged into the machine [A] and the wall socket.

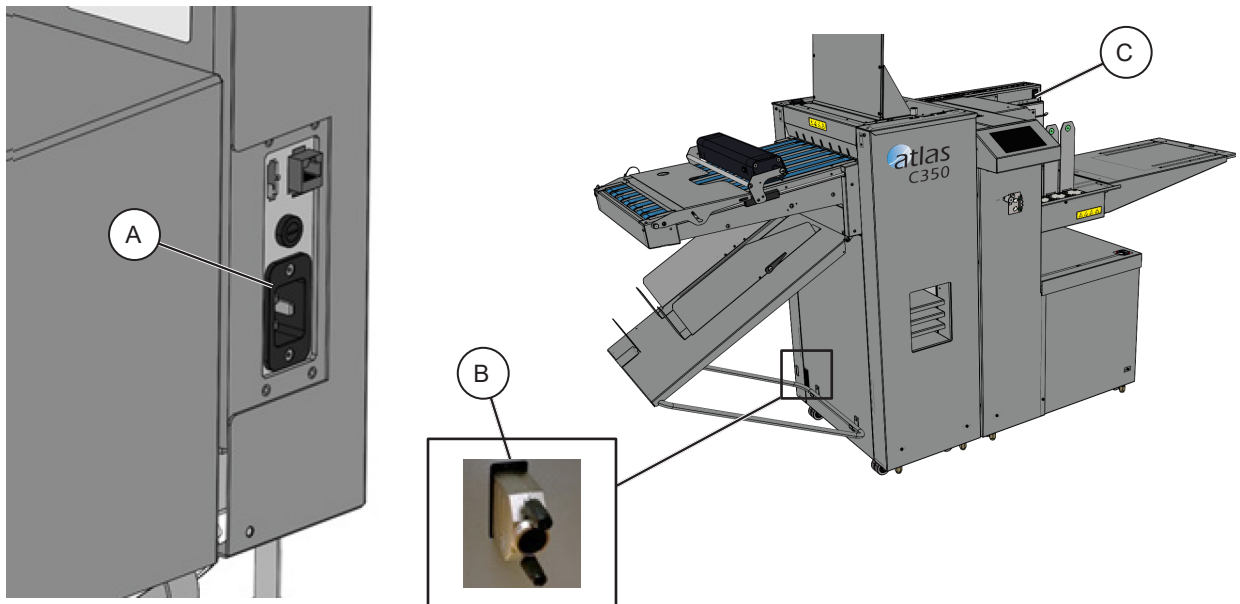

2. Ensure the CAN termination plug [B] is plugged in.
3. Toggle the main power switch [C] to turn the machine on.
4. To turn the machine off again toggle the main power switch [C] again.

 **NOTE:**

If the CAN termination plug is not plugged in the machine may not function correctly.

Job Preparation

Paper stack preparation

Before loading paper in this machine, it is recommended to fan the sheets as shown.

1. Hold the paper stack on a flat surface as shown

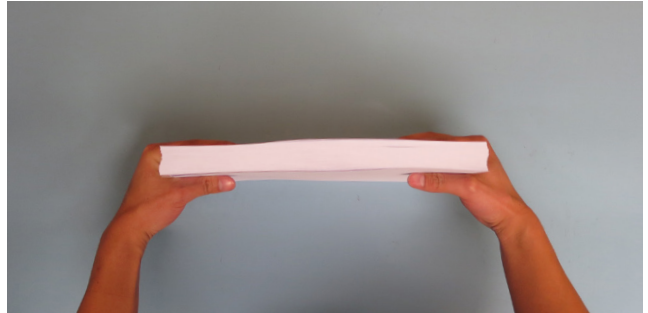

2. Bend the paper stack



3. Use your fingers and thumbs to pinch the paper stack



4. With the paper pinched between your fingers, straighten out the paper stack

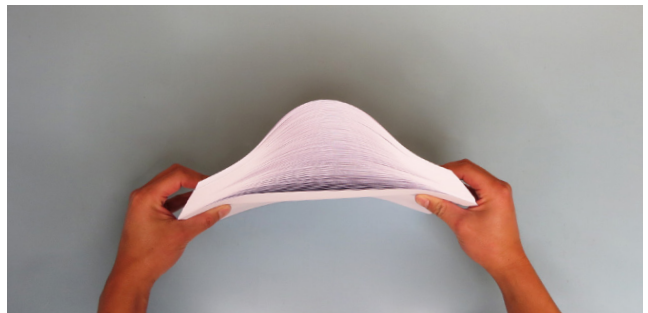

Continued on next page...

Paper stack preparation (continued)

5. Flex the paper back and forth a couple of times to break surface tension and preseparate the sheets



2

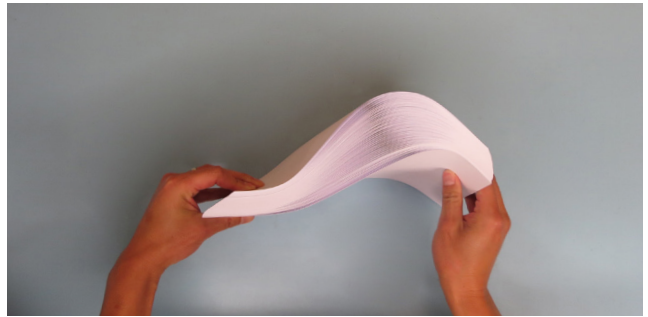

6. Realign the sheets into a stack before putting them into the tray

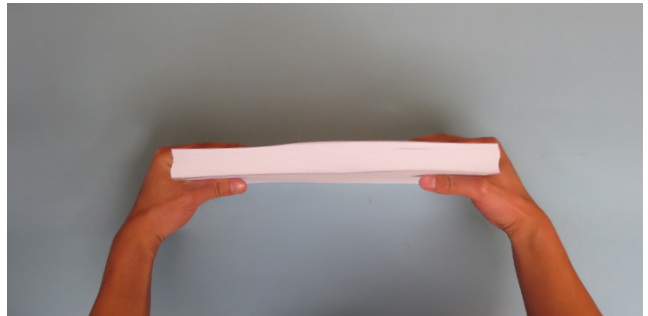

 **NOTE:**

If the sheets you are using are too stiff or too large format to carry out the above procedure, fan the front edge of the sheets when loading them in the machine.

Measuring the paper curl

Take a sample of the stack (about 15 mm / 0.59" high) and place it on a flat surface

2

1. Take the midpoint as reference and do all the measurements within the marked area of the picture (from the center to the leading edge in paper feed direction)

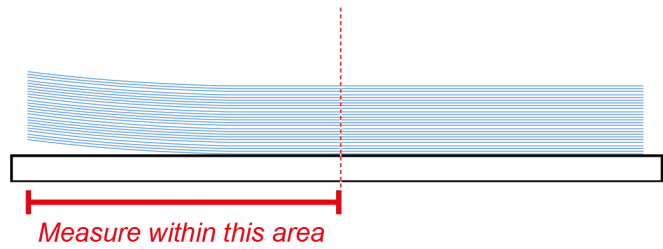

2. Measure the lowest point of the stack of paper

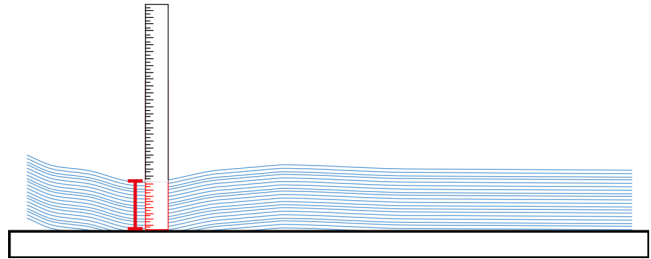

3. Measure the height of the leading edge of stack of paper: the difference between the leading edge and the lowest point is the amount of paper curl

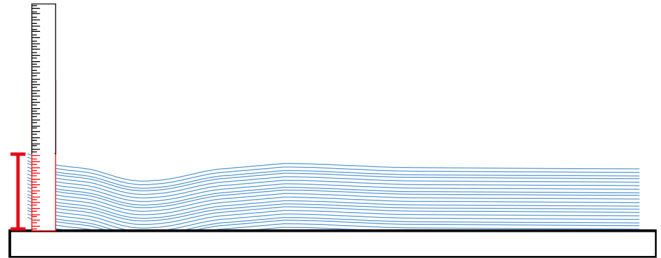

This procedure can also be used to measure the cross process direction curl.

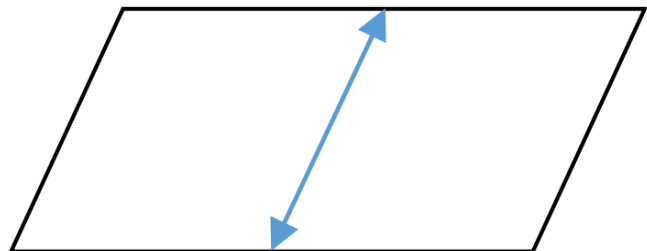

Loading Paper

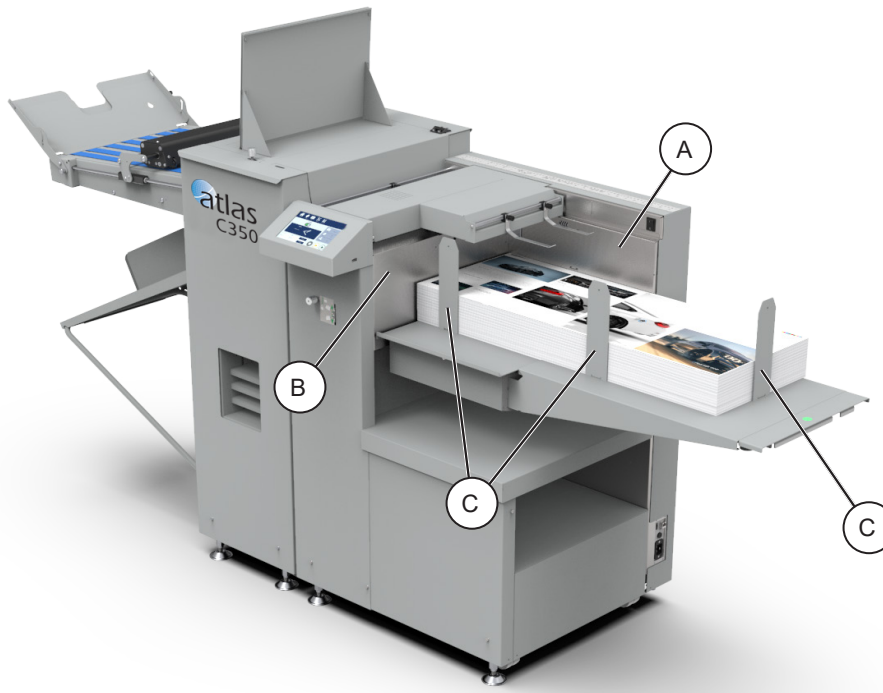

2

1. Take a stack of printed paper and place it on the feeder table in the desired orientation.

 **NOTE:**

If using sheets longer than 450 mm (17.7"), but shorter than 700 mm (27.6") extend the built-in pull-out table. If using sheets longer than 700 mm (27.6") see the optional "Feeder Table Extension" section within this manual.

2. Ensure the paper is pushed into the corner and is aligned to both the registration wall [A] and the front wall [B].
3. Align the magnetic paper guides [C] with the edges of the paper stack. Ensure the guides are not too tight and the sheets can move freely.

 **NOTE:**

To make sure the magnetic paper guides are not too tight put a single sheet of paper between the stack and the guide when setting the guide.

Feeder Table Extension (optional)

Install table extension if using sheets longer than 700 mm (27.6”):

1. Ensure the built-in pull-out table [A] is fully stowed.

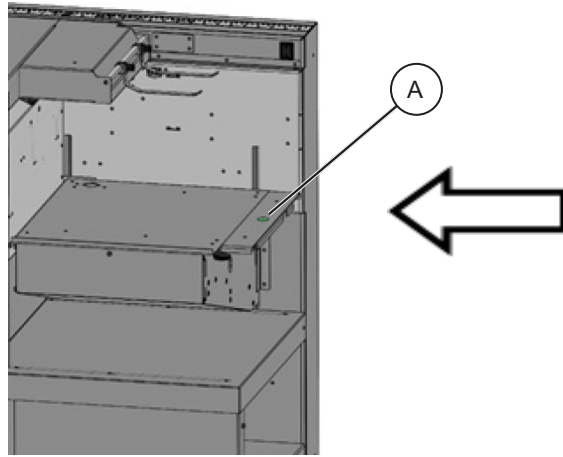

2. Hook the table extension [B] into the lift [C] as shown.

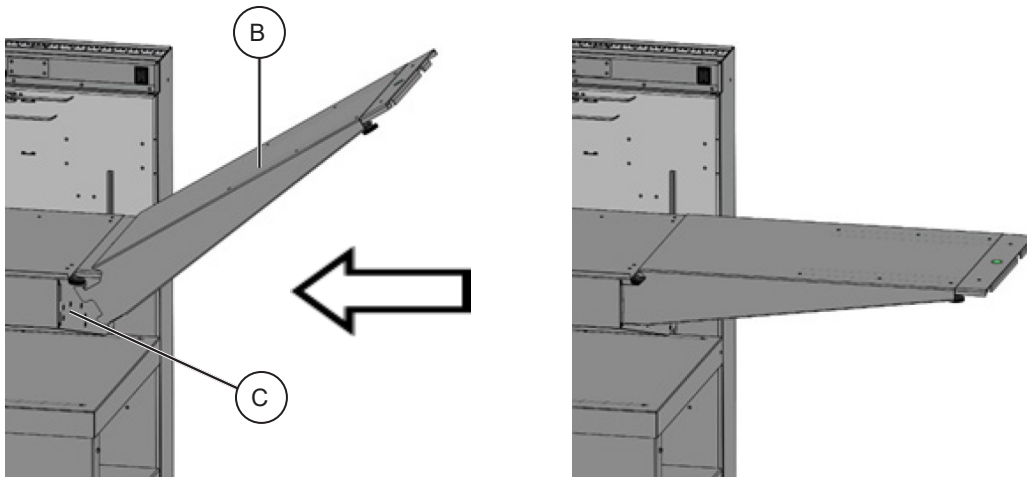

 **NOTE:**

The feeder table extension has a built-in pull out part that can be used to feed sheets up to 1300 mm (51”).

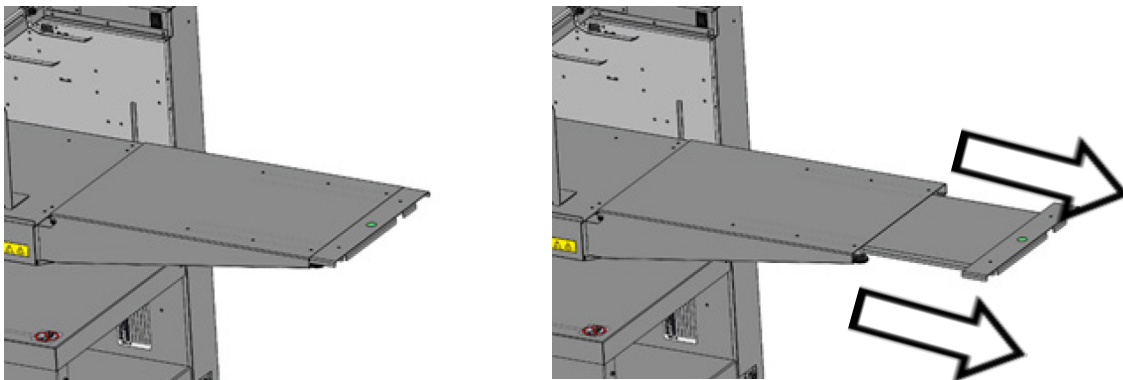

Stacker Settings

Stacker Settings Menu

The machine automatically adjusts the stacker settings when a job is selected, these settings will not always be appropriate for certain custom jobs or all paper types see 'Paper Guidelines' section. If the job being run is not stacking correctly follow the below section.

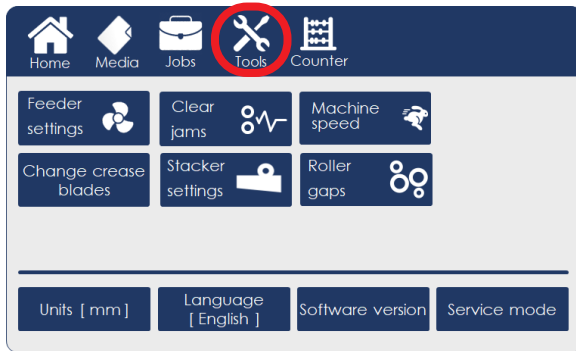

1. Select the Tools icon [A].

2

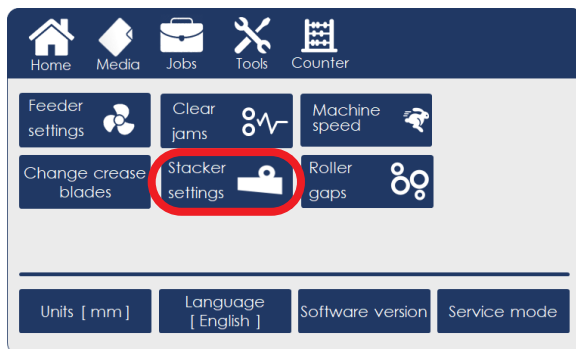

2. Select stacker settings [B].

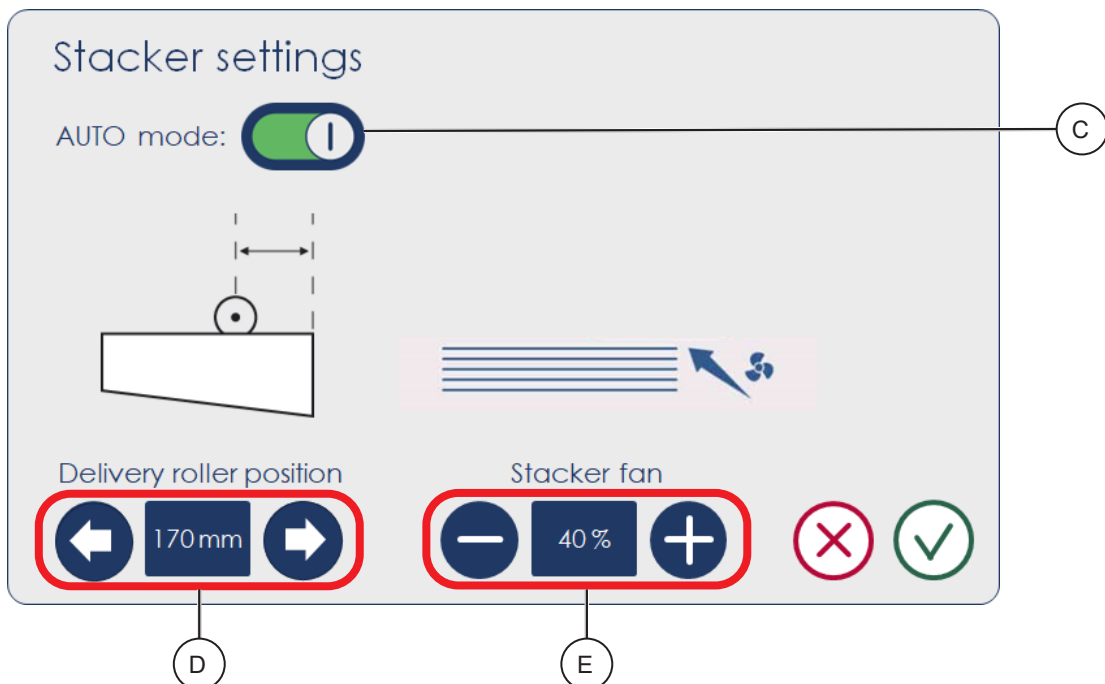

Continued on next page...

Element	Description	Operation
A	Tools menu	Advanced operator settings & tools
B	Stacker settings	Fine adjustment if work is not stacking correctly
C	Auto mode	Toggles auto setting for selected job
D	Delivery roller position	Manual roller position adjustment (Fold On)
E	Stacker fan	Manual stacker fan adjustment (Fold Off)
F	Delivery roller button	Allows delivery roller to be moved manually.
G	Air flow direction	Allows stacking for fold-off jobs
H	Magnetic stacker guides	Collects paper when the fold is off

Folding Stacker Settings

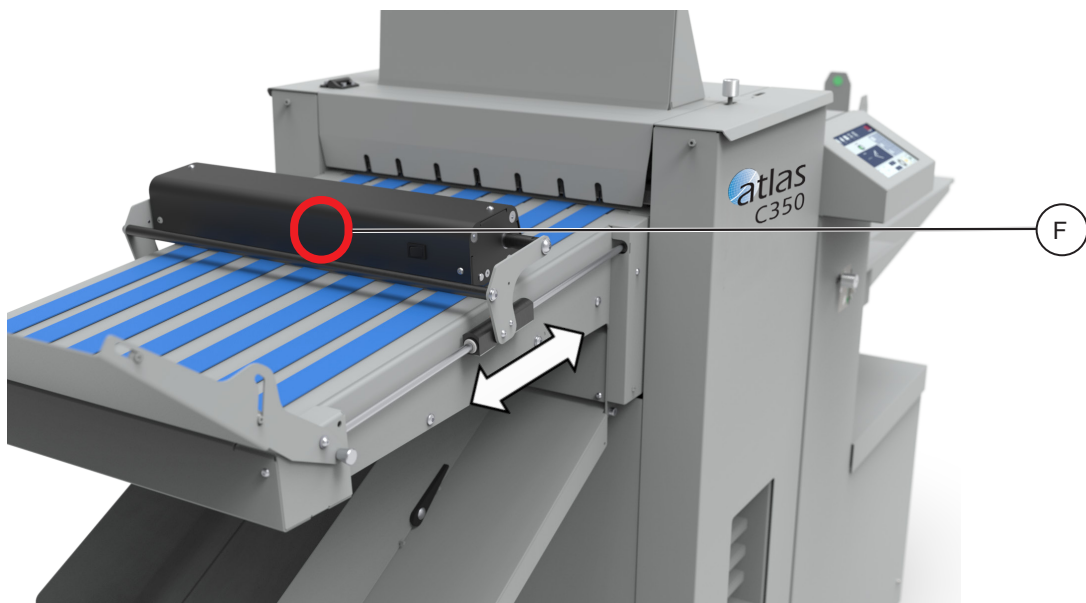

There are two ways to adjust the position of the delivery roller position:

- Stacker settings page [D].
- Manually by pressing the physical button [F].

1. Follow steps 1 & 2 on Stacker Settings page.
2. Press either direction button [D] to move delivery roller closer or further from paper exit.
3. Distance from paper exit is displayed in the centre of the direction arrows [D].
4. Run more sheets to check adjustment has improved stacking, repeat if necessary.

Or

1. Press button [F].
2. Physically move delivery roller closer or further from paper exit.
3. Run more sheets to check adjustment has improved stacking, repeat if necessary.

Continued on next page...

Fold-Off Stacker Settings

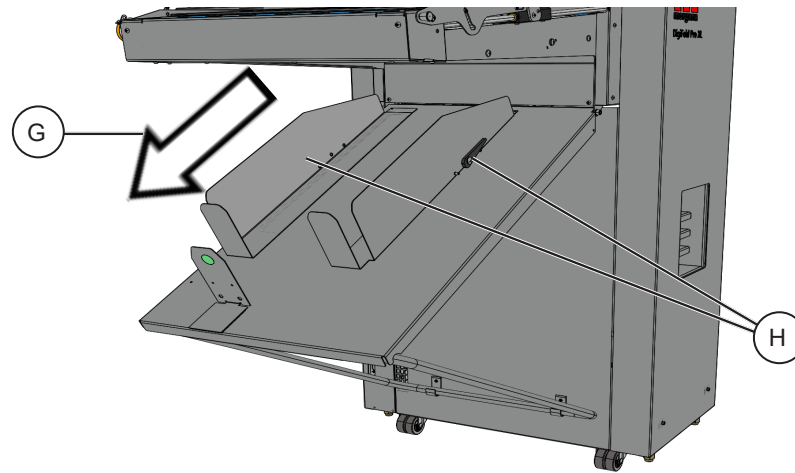

2

 **NOTE:**

To make sure the magnetic paper guides are not too tight put a single sheet of paper between the stack and the guide when setting the guide.

1. Take a single sheet from the stack and use it to set the magnetic stacker guides to the correct paper size. Use the lever [H] to raise the stacker guides from the surface to make them easier to move.
2. Follow steps 1 & 2 on Stacker Settings page.
3. Press either direction button [E] to increase or decrease fan speed.
4. Fan speed is displayed as a percentage in the centre of the direction arrows [E].
5. Run more sheets to check adjustment has improved stacking, repeat if necessary.

Page intentionally left blank

Page intentionally left blank

The Home Screen

Overview

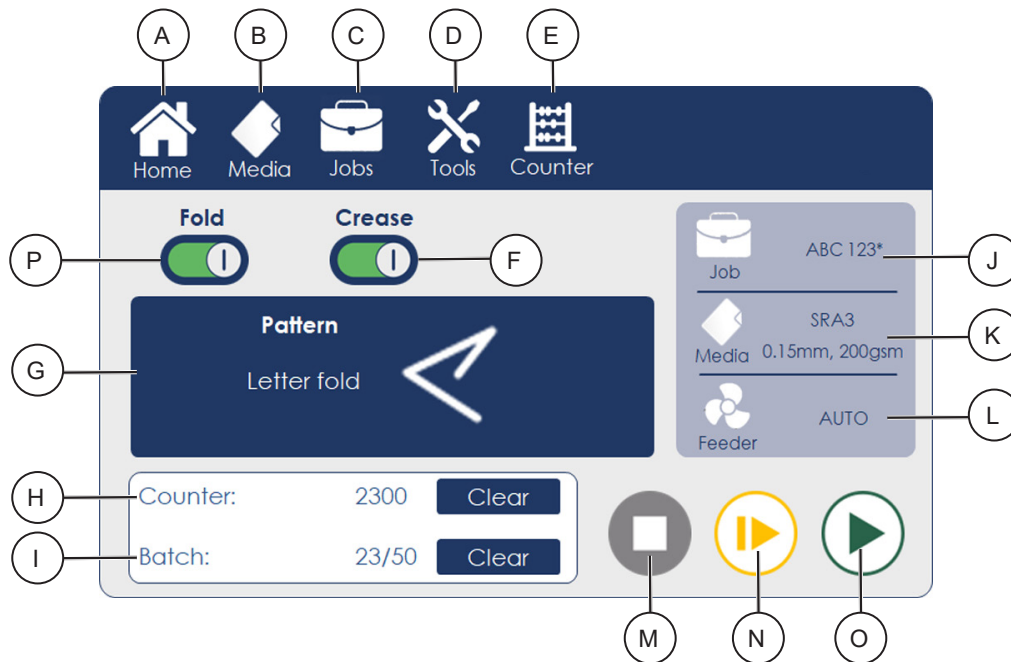

Element		Description
A	Home button	Returns to this screen
B	Media button	Set paper size and thickness for this job
C	Jobs button	Save / load job
D	Tools button	Access additional machine settings
E	Counter button	Set batch counter mode
F	Crease switch	Switch creasing on or off
G	Pattern button	Choose a pre-set or custom crease pattern
H	Total counter	Displays the number of sheets processed since it was last cleared. "Clear" button resets it back to zero.
I	Batch counter	Displays the number of sheets processed in this batch and the batch size. "Clear" button resets it back to zero.
J	Job name	Displays current job name. Asterisk (*) indicates that job parameters have changed since the job was last saved.
K	Media type	Displays currently selected paper size and thickness
L	Feeder settings	Displays feeder operation mode – Auto or Custom
M	Stop button	Stops the machine cycle
N	Proof / Pause button	Processes a single proof sheet with the current settings. If the machine is running, pauses the cycle
O	Play button	Starts the machine cycle with the current settings.
P	Fold switch	Switch folding on or off

Paper Size

To set paper size and type:



1. Choose Media from the top menu in the Home screen.

NOTE:
Changing paper size or thickness will reset any fine adjustments that may have been entered on other screens.

2

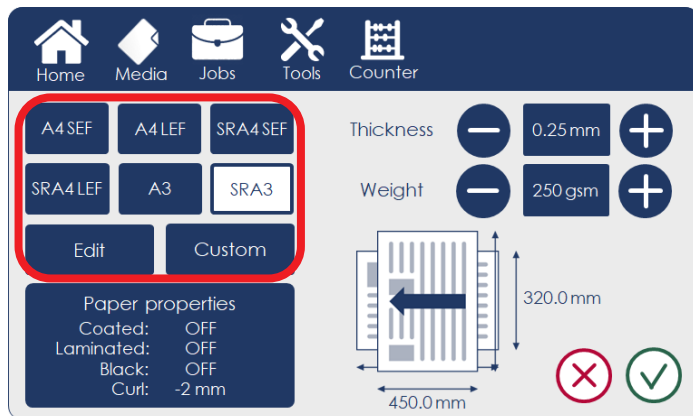

2. Select one of the preset paper sizes or select custom size.

To make an alteration after selecting a preset or custom paper size select Edit.

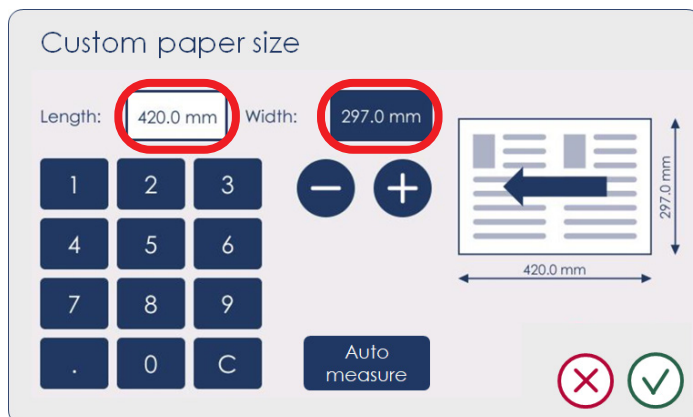

3. Click on Length and Width to enter the desired custom size. Click the green check mark to confirm.

Continued on next page...

Paper Size (continued)

2

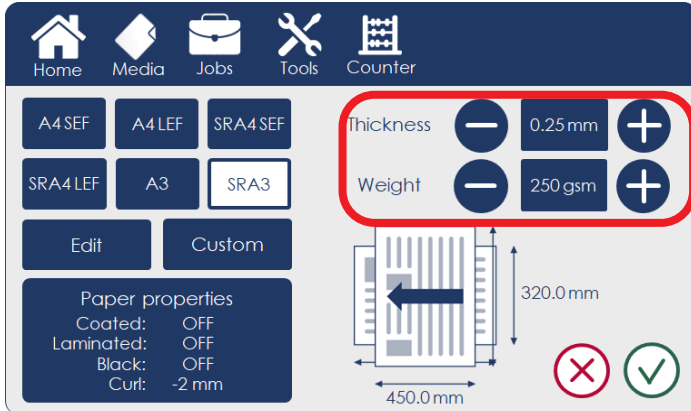

4. Set paper thickness and paper weight.

 **NOTE:**
Measure paper thickness using the included vernier caliper.

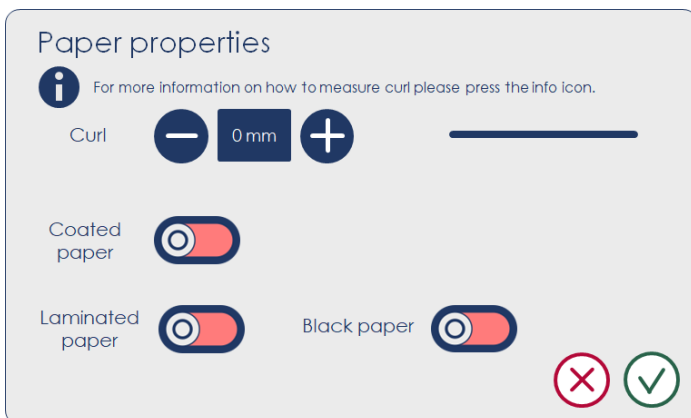

5. Paper properties: Enter paper surface finish and curl if necessary see 'Measuring the paper curl'.

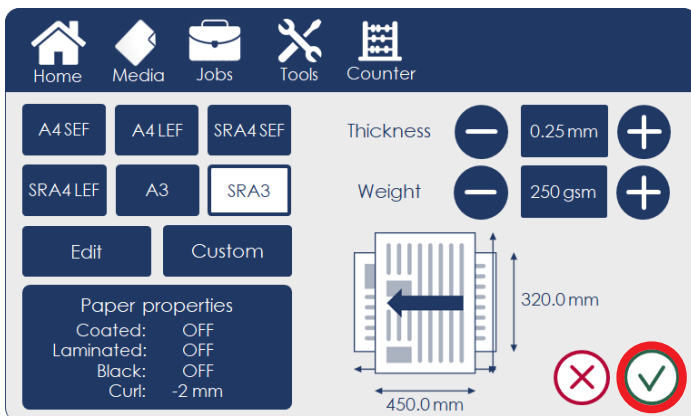

6. Confirm the settings by clicking the green check mark.

Pre-set Patterns

To set up one of the pre-defined creasing patterns:



1. Click the Pattern button on the Home screen

NOTE:
Choosing a new pre-set pattern will reset any fine adjustments that may have been entered on other screens.

2

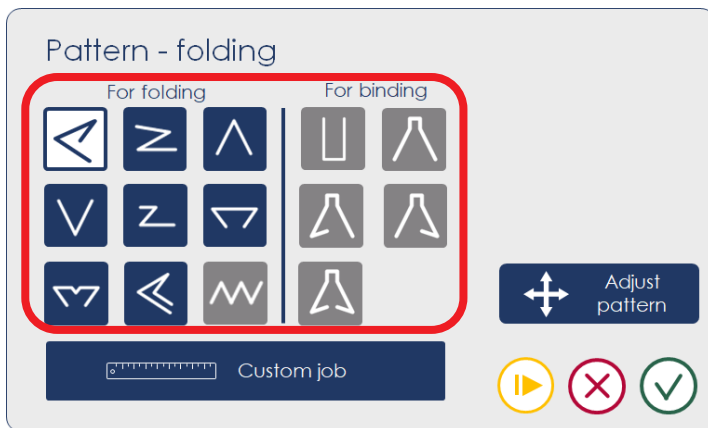

2. Select one of the pre-defined crease/fold patterns. The left column contains patterns for typical folded jobs. The right column contains patterns for book covers, typical for crease only jobs.

NOTE:
The position of the Crease Switch and Fold Switch define patterns that can be selected.

NOTE:

You can also choose Custom job to set up your own pattern. See “Custom Job” section of this manual for details.

	Letter fold (tri-fold)		Double parallel fold
	Concertina fold (Z fold)		Equally spaced creases
	Half fold A		Spine crease
	Half fold V		Hinge crease
	Engineering fold		Hinge crease with front flap
	Gate fold		Hinge crease with rear flap
	Closed gate fold		Hinge crease with two flaps

Continued on next page...

2

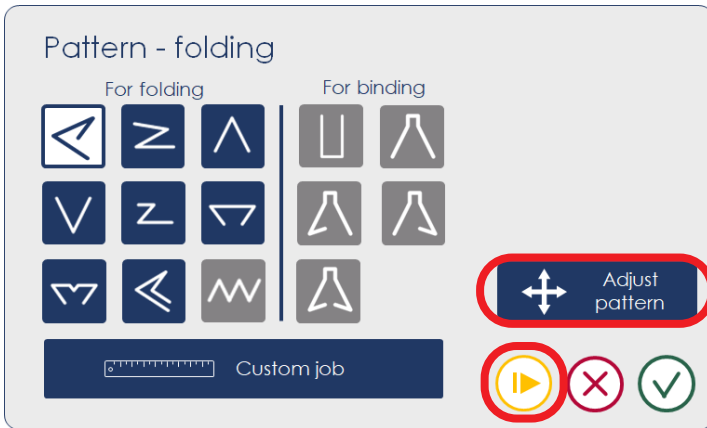

3. Click the Proof button to run a single sheet. Inspect the output:
 - If the job is as desired click the green check mark to confirm the job and return to the Home screen.
 - If the job requires adjustment click the Adjust pattern button



4. Each pattern has an adjustment screen that allows making small corrections to crease positions to achieve the desired output. Use the + / - buttons to make the adjustment and press the Proof button to run another proof sheet. When satisfied click the green check mark.

NOTE:

If **optional** Crease tool is fitted you can also choose which crease tool to use by clicking the Crease tools button.

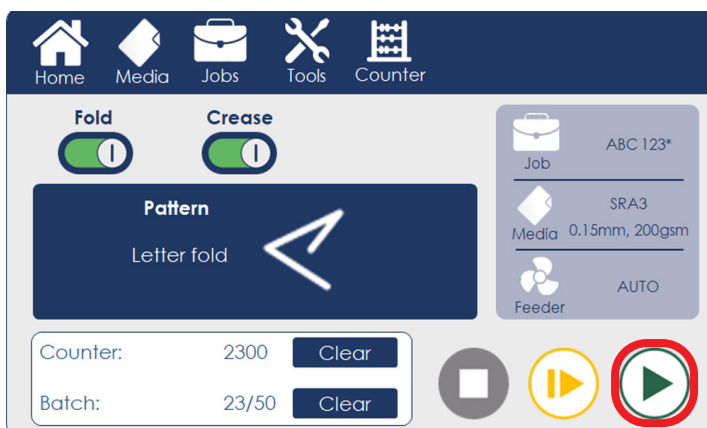

5. On the Home screen click the Play button to start the machine cycle.

Custom Job

To fully customize the number and position of creases on the sheet set up a custom job:



1. Click the Pattern button on the Home screen

NOTE:
Choosing a new pattern will reset any fine adjustments that may have been entered on other screens.

2

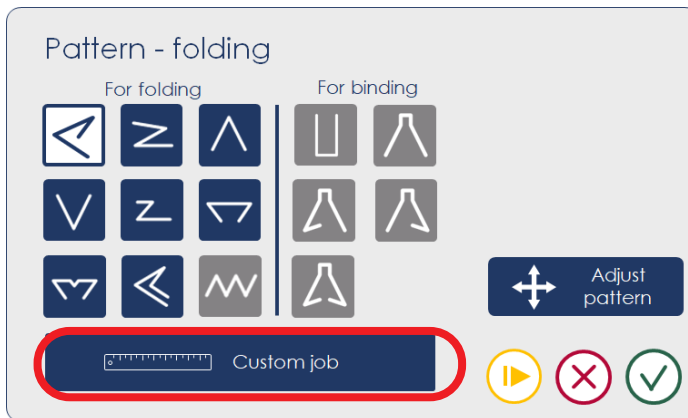

2. Select Custom job.

NOTE:
The custom job will be based on the previously selected pre-set.

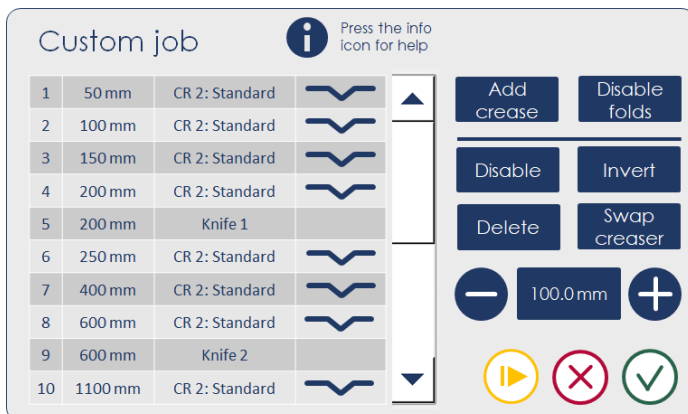

3. Custom job screen:

- Click Add crease to add more creases to the list.
- Select a crease and use the + / - buttons to adjust its position.
- Use the Delete button to remove the selected crease from the list.
- The Swap creaser button can be used to select whether the 1st or the 2nd creaser will be used to make this crease (only available if the optional creaser unit has been installed).
- Use the Proof button to test run a single sheet.
- When satisfied, click the green check mark.
- Use the Disable button to temporarily suspend the selected crease without deleting it (for example, when programming jobs in two passes)
- The Invert button disables all currently enabled creases and enables all currently disabled creases. Use this when running jobs in two passes.

Roller Gap Adjustment

This sub-menu allows the user to adjust the distance between the rollers manually:

2



1. Click the Tools button on the Home screen

NOTE:
This feature should only be used if the default settings are not working properly.

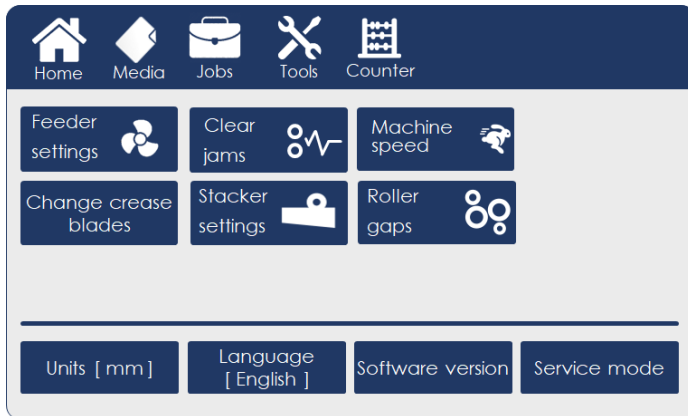

2. Select Roller gaps.

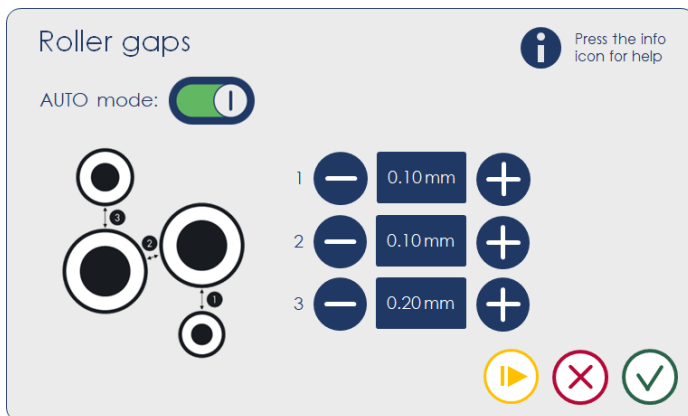

3. Make changes as required.

Roller Gap Default Settings

Fold Configuration	Gap 3	Gap 2	Gap 1
Half K1 (Half Fold on Knife 1)	2X	2X	X
Half K2 (Half Fold in Knife 2)	2X	X	X
Double Parallel	4X	2X	X
Engineering	3X	X	X
Closed Gate	3X	X	X
Letter	3X	X	X
Concertina	3X	X	X

Atlas C350 Quick Reference Sheet

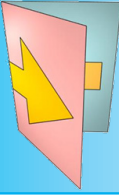
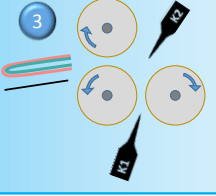
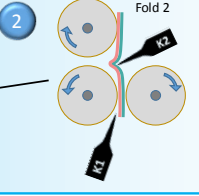
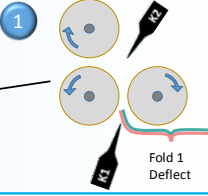
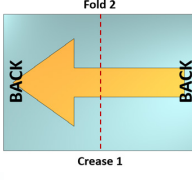
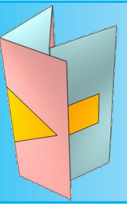
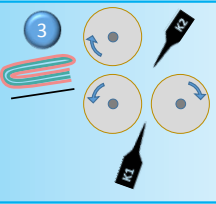
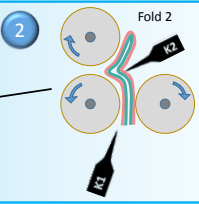
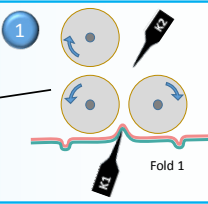
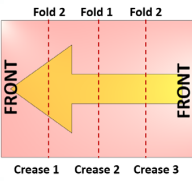
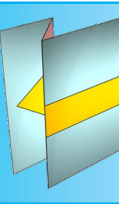
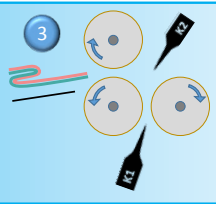
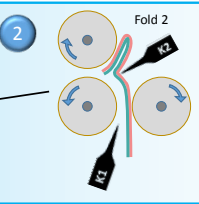
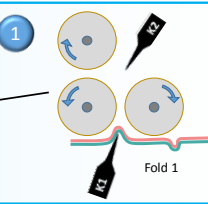
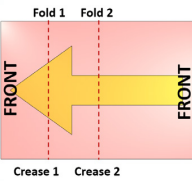
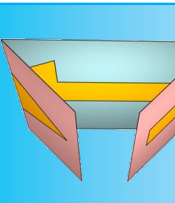
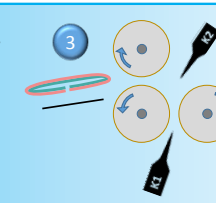
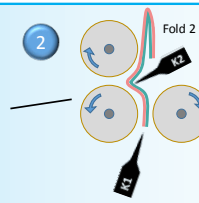
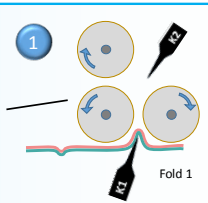
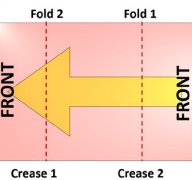
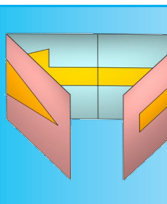
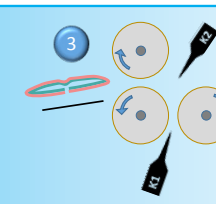
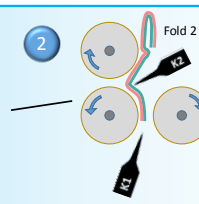
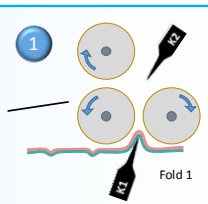
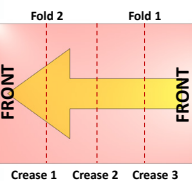
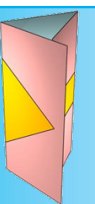
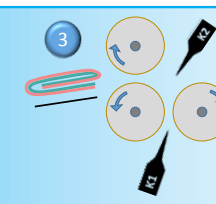
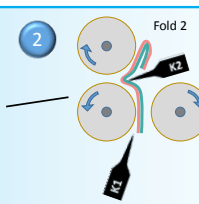
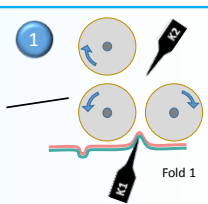
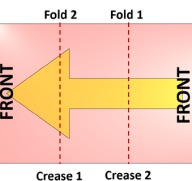
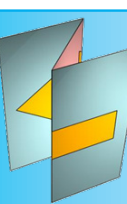
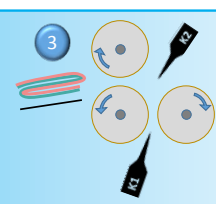
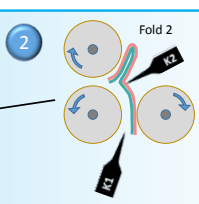
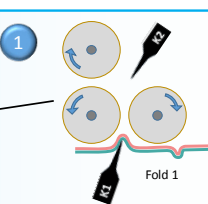
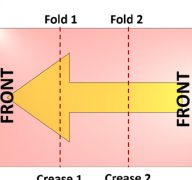
<p>Half Fold K1 K2</p> 				
<p>Double Parallel Fold</p> 				
<p>Engineering Fold</p> 				
<p>Gate Fold</p> 				
<p>Closed Gate Fold</p> 				
<p>Letter Fold</p> 				
<p>Concertina Fold</p> 				

Saving and Loading Jobs

To store a customized job or to load a previously saved job:

2



1. Choose Jobs from the top menu on the Home screen



NOTE:

The current job name is displayed in the box on the right. Asterisk (*) following the job name indicates that there are unsaved changes to this job.

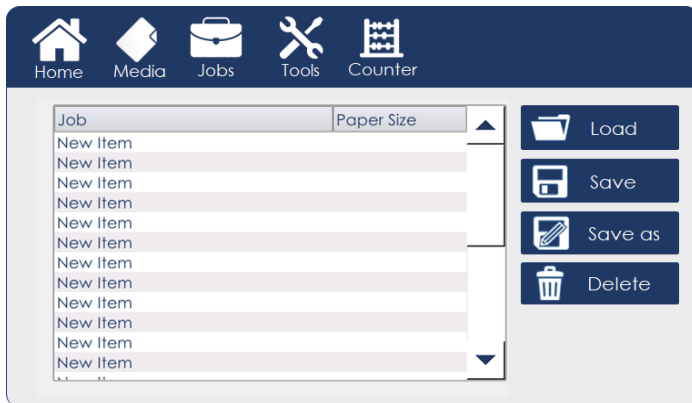

2. To save the current settings, click Save or Save as. To load a previously saved job, click Load.

Load – loads the currently selected job.

Save – saves the current job

Save as – saves the current job under a new name

Delete – erases the currently selected job.



NOTE:

Loading a job will overwrite the current settings.

Counters

Once the machine cycle is started by default this machine will continue processing sheets until there is no more paper on the table. Alternatively, the machine can be configured to run in batch mode:

- Stop mode – the machine will stop after the specified number of sheets has been processed. If another cycle is started by the operator another batch with the specified number of sheets will be processed.
- Pause mode – the machine will pause for a short time after the specified number of sheets has been processed and start processing another batch automatically.

NOTE:

It is convenient to set up batch mode with a short pause to let the operator work in tandem with the machine. While the machine is paused the operator can remove the finished sheets from the stacker and pack or process them further while the machine produces the next batch.

To set up batch mode:



1. Choose Counter from the top menu on the Home screen

NOTE:

Current total and batch counters are displayed at the bottom of the Home screen. They can be reset at any time by clicking the Clear buttons.

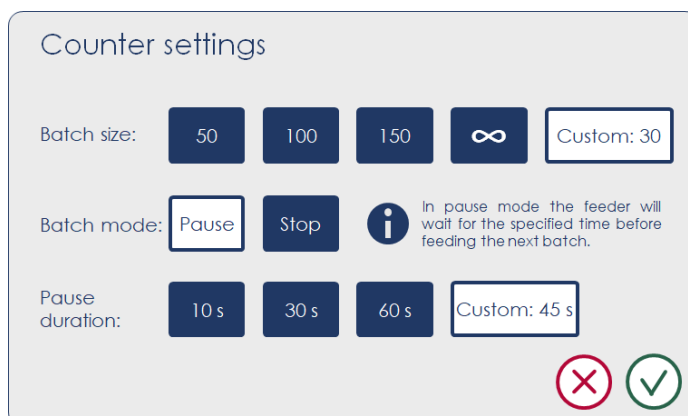

2. Select the desired batch size. Selecting the infinity symbol (∞) switches off batching.
3. Selected batch mode – Pause or Stop.
4. For pause mode specify the desired pause duration between batches.
5. Click the green check mark to confirm your selection and return to the Home screen.

The Tools Screen

Overview

The Tools screen allows the operator to adjust advanced machine settings. To access the Tools screen:

2

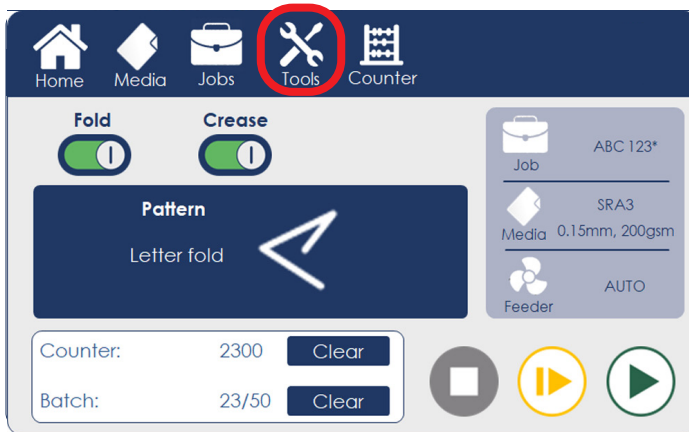

1. Choose Tools from the top menu on the Home screen

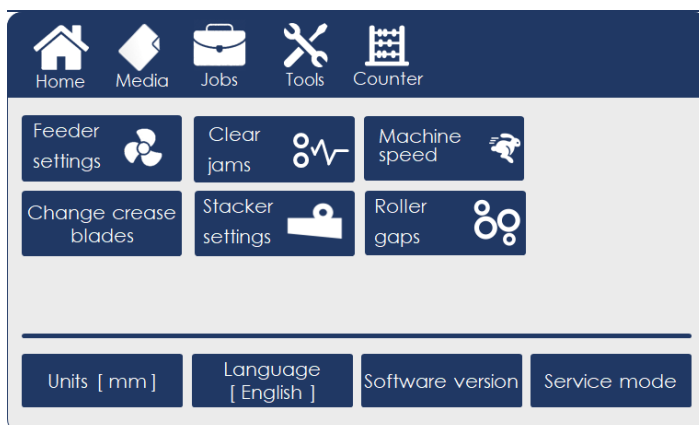

2. Select the desired function.

Element	Description
Feeder settings	Allows the adjustment of feeder fan, lift and sensor settings in case the automatic settings do not provide satisfactory feeding performance.
Clear jams	Jog machine rollers and creasing tools to dislodge any jammed paper.
Machine speed	Adjust machine operations speed for processing especially sensitive or difficult stocks.
Change crease blades	Set the currently installed creasing / perforation tools.
Units [mm/in]	Toggles between millimeters (mm) and inches (mm).
Language	Cycles through all available user interface languages.
Software version	Displays currently installed software version.
Service mode	For certified service technicians.

Feeder Settings

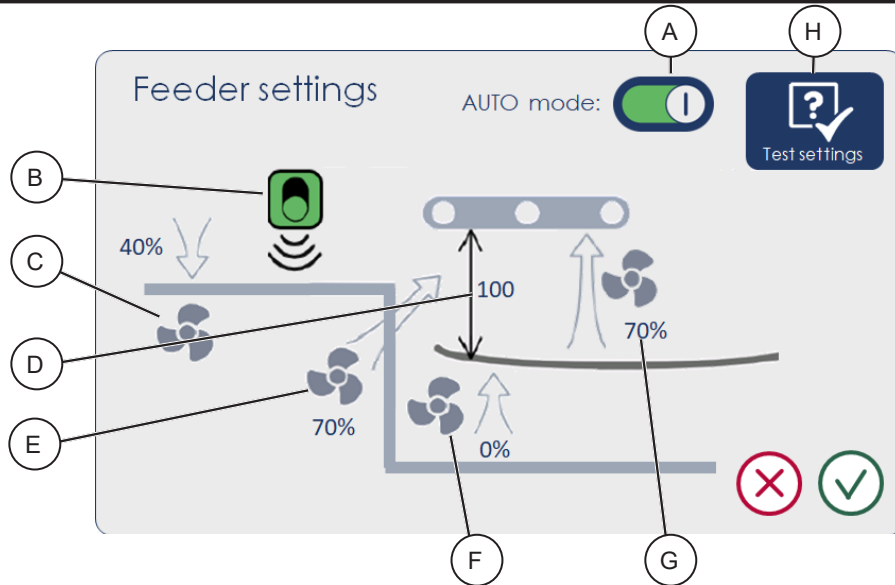

2

Element		Description
A	AUTO settings	Toggles automatic feeder mode. In AUTO mode feeder settings are calculated automatically depending on paper size and weight. In most cases AUTO settings will provide optimum feeding performance. Switching AUTO settings off allows the operator to make adjustments to fans.
B	DSD settings	Allows the operator to switch ultrasonic double sheet detection (DSD) off. For some media types such as thick card or laminated media the ultrasonic sensor may give incorrect readings. In this case switch the sensor off.
C	Registration fan	Adjusts the force with which the sheet is registered against the paper wall. Increase this if the sheets exit the feeder in an inconsistent orientation. Thinner sheets can be damaged (over-registered) if this value is set too high.
D	Paper density	Paper density is a value measured by the separated paper (SP) sensor. A higher value means more sheets are floated and the unfloatable pile is closer to the vacuum belts.
E	Separation fan	The front separation fan (air knife) floats the top sheets in the pile. Insufficient separation air can result in frequent misfeeds, while excessive airflow can float too many sheets and result in double feeds.
F	Side float fan	The side fan can be used to add additional air for media that is difficult to separate with the front fan only. Excessive side float air can cause issues with registration.
G	Vacuum fan	Vacuum fan controls the force with which the top sheet in the pile is pulled in contact with the feed belts. Insufficient vacuum can result in frequent misfeeds, while excessive vacuum can pick up several sheets and result in double feeds.
H	Test settings	This button allows the operator to start all feeder fans to check if the sheets are separating properly.

Clear Jams

Use this screen to jog rollers and tools to help with removing paper jams in the machine.

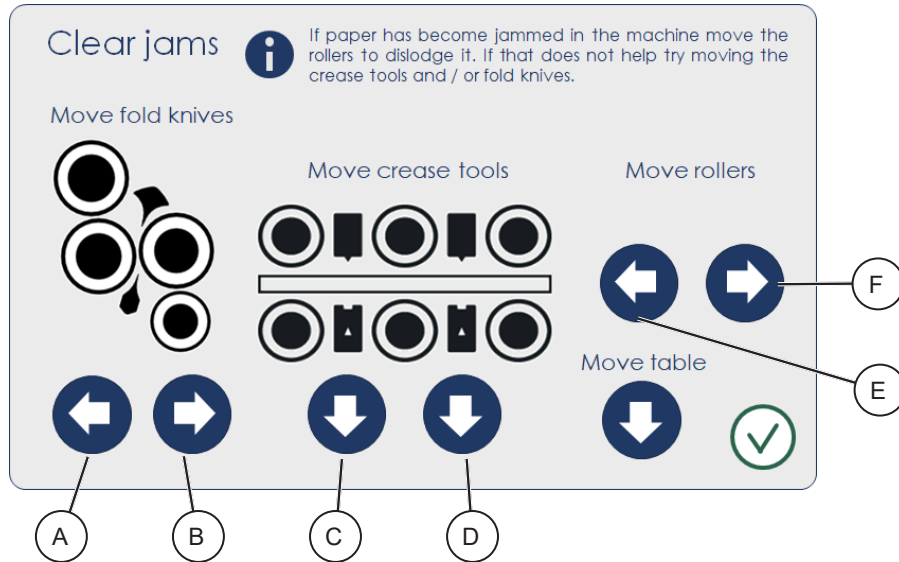

Element		Description
A	Cycle fold knives in process direction	Move knives in the process direction in short bursts.
B	Cycle fold knives against process direction	Move knives against the process direction in short bursts.
C	Open creaser 2	Opens the crease tool in case it has remained closed after a paper jam.
D	Open Creaser 1	Opens the crease tool in case it has remained closed after a paper jam. <i>NOTE: This button is greyed out if creaser 1 is not installed.</i>
E	Move rollers in process direction	Move rollers in the process direction in short bursts.
F	Move rollers against process direction	Move rollers against the process direction in short bursts.

Change Crease Blades

When replacing creasing blades choose the currently installed creasing blades on this screen.

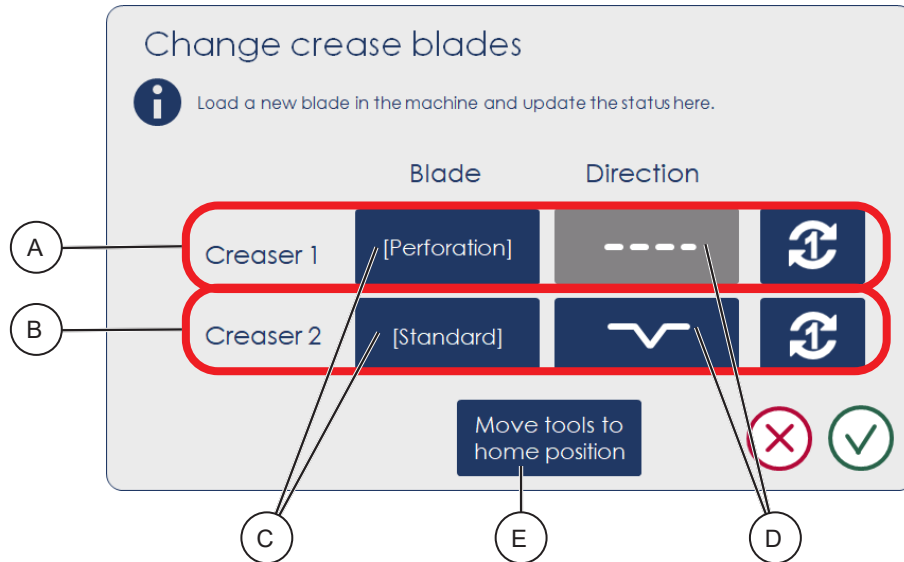

Element	Description
A Creaser 1 Optional	Quick Release Blade Static Creaser <i>NOTE:</i> <i>The perforation blade option can be chosen.</i>
B Creaser 2	DynaCrease Blade Set <i>NOTE:</i> <i>Not compatible with perforation.</i>
C Blade buttons	Choose the type of blade currently installed in each creaser: [Standard], [Narrow], [Extra Narrow] or [Perforation]. Based on this setting machine parameters will be adjusted to suit the blade.
D Direction buttons	Set the creasing direction (up or down) of each creaser. <i>NOTE:</i> <i>The perforation blade direction cannot be chosen.</i>
E Home position button	Use this button to move the creasing mechanism to its home position. This helps when inserting / removing the blade set.

NOTE:

For blade set replacement instructions, see the “Replacing Dynamic Crease Blade Sets” or “Replacing Quick Release Blade Sets” section within this manual.

Page intentionally blank.

3. Troubleshooting

General

Misfeeds / Jams

If a misfeed or a jam condition should occur, it is indicated on the machine display. A message with the jam description, error code and approximate jam location is displayed.

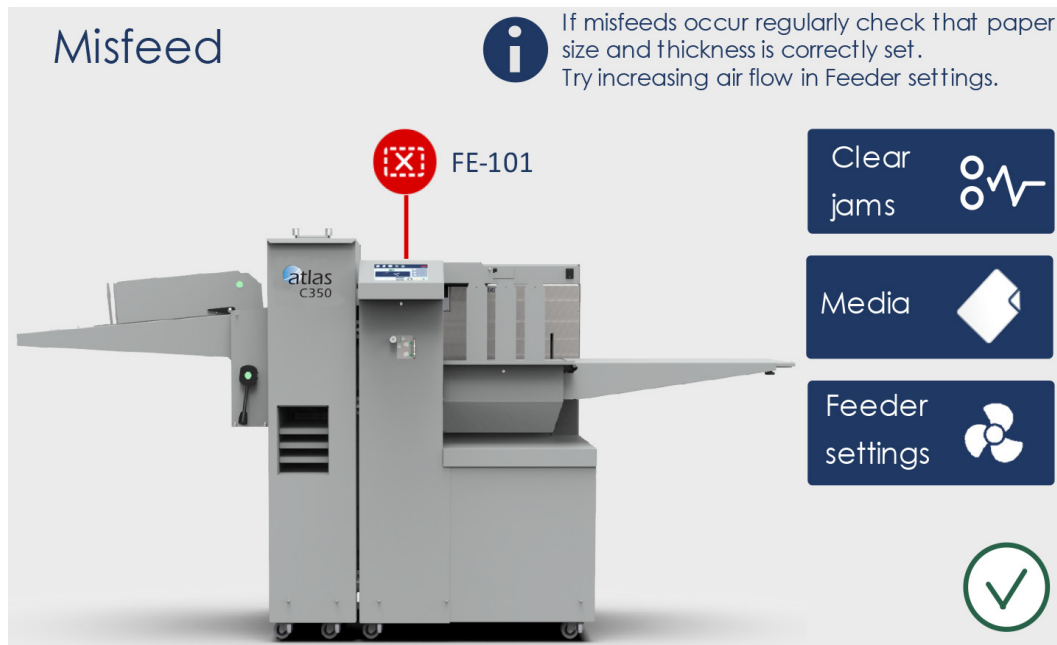

NOTE:

Clicking on the fault code will open a short description of the issue.

Misfeed / Jam in the Feeder

1. Inspect the feed belt area for misfed sheets.
2. Inspect the registration area for misfed sheets.
3. If the sheet has been damaged, discard it. Otherwise, reposition it back on the lift.
4. Once the area has been cleared press the green check mark on the screen.

Misfeed / Jam in the Folder

1. Click Clear jams on the jam screen or go to Tools and click Clear jams.
2. Open the top cover and inspect the area. If possible, remove the jammed sheet. Removing the rotary tool carrier and creasing blade(s) may help accessing the sheet.
3. If not, close the top cover and use the controls on the screen to jog the rollers to help with removing the sheet.
4. Once the area has been cleared, re-insert the rotary tool carrier and close the top cover. Press the green check mark on the screen.

Continued on next page...

Fault Codes

List of Fault Codes

To address fault codes other than those specified below, remove any paper in the paper path and power the system off and on again. If the fault code persists, contact a certified service technician.

Feed section - FE

Fold section - FO

List of fault codes that can be rectified by the operator:

3

FE-101 – Misfeed

FE-102 – Double sheet

FE-103 – Sheet too long

FE-104 – Sheet too short

FE-106 – Out of paper

FE-108 – Paper table overloaded

FE-109 – Too much paper

FE-112 – Double sheet detector (DSD) blocked

FO-301 Fold Jam between units B

FO-302 Fold Jam between units C

FO-305 Fold Fold 1 Sensor not covered in time

FO-306 Fold Fold 1 Sensor not uncovered in time

FO-309 Fold Folder 1 Position Error

FO-310 Fold Folder 2 Position Error

FO-311 Fold Folder Position Error

FO-312 Fold Exit Sensor not covered in time

FO-313 Fold Exit Sensor not uncovered in time

FO-314 Fold Edge Sensor not covered in time

FO-315 Fold Edge Sensor not uncovered in time

Continued on next page...

FE-101 - Misfeed

This code is displayed if the ultrasonic double sheet detector (US DSD) Q10 was not activated in time after the start of the feed cycle. This means that the sheet has failed to exit the feeder table area.

Actions:

- Remove the jammed sheet (if any) from underneath the vacuum belts. If the sheet is damaged, discard it.
- Check the paper path for any obstructions or debris.
- Check that the paper loaded in the feeder matches the parameters (size and thickness) set in the UI.
- Fan the paper stack to ensure sheets are not stuck together and there is no excessive buildup of static electricity.
- Check that feeder magnetic side guides do not stop the sheet from freely exiting the feeder.
- If frequent misfeeds keep occurring after carrying out the above actions:
- Check that the sheet can freely pass between the separation pads and the vacuum belts.
- Turn off feeder AUTO settings and increase one or more of the following parameters: paper density, vacuum fan, separation fan.

NOTE:

See the “Feeder Settings” section of this manual for instructions on how to do this.

FE-102 - Double sheet

This code is displayed when the ultrasonic double sheet detector (US DSD) Q10 has detected two or more overlapping sheets exiting the feeder at the same time.

Actions:

- Remove the jammed sheets from underneath the vacuum belts. If the sheets are damaged, discard them.
- Check the paper path for any obstructions or debris.
- Check that the paper loaded in the feeder matches the parameters (size and thickness) set in the UI.
- Fan the paper stack to ensure sheets are not stuck together and there is no excessive buildup of static electricity.
- If frequent double feeds keep occurring after carrying out the above actions:
- Turn off feeder AUTO settings and increase one or more of the following parameters: paper density, vacuum fan, separation fan.
- If using laminated paper or other multi-layered stock, switch off the US DSD.

NOTE:

See the “Feeder Settings” section of this manual for instructions on how to do this.

Continued on next page...

FE-103 - Sheet too long

When a sheet exits the feeder the ultrasonic double sheet detector (US DSD) Q10 measures its length to ensure the sheet matches machine settings. Error code FE-103 is displayed if the sensor Q10 is covered longer than expected. This can be either because the sheet is too long or because there is insufficient grip on the registration belts and the sheet cannot be fed forward.

Actions:

- Remove the jammed sheet from underneath the vacuum belts. If the sheet is damaged, discard it.
- Check the paper path for any obstructions or debris.
- Check that all sheets in the stack are the same length.
- Check that the paper loaded in the feeder matches the parameters (size and thickness) set in the UI.
- Fan the paper stack to ensure sheets are not stuck together and there is no excessive buildup of static electricity.
- Check that feeder magnetic side guides do not stop the sheet from freely exiting the feeder.

FE-104 - Sheet too short

When a sheet exits the feeder the ultrasonic double sheet detector (US DSD) Q10 measures its length to ensure the sheet matches machine settings. Error code FE-104 is displayed if the sensor Q10 is covered for less time than expected.

Actions:

- Remove the jammed sheet (if any) from underneath the vacuum belts. If the sheet is damaged, discard it.
- Check the paper path for any obstructions or debris.
- Check that all sheets in the stack are the same length.
- Check that the paper loaded in the feeder matches the parameters (size and thickness) set in the UI.
- Fan the paper stack to ensure sheets are not stuck together and there is no excessive buildup of static electricity.

FE-106 - Out of paper

Table empty sensor Q11 checks if paper is present on the table during the feed cycle. If no paper is detected, the machine stops the cycle and displays code FE-106. In most cases this is part of normal operation and is not a cause for concern.

Actions:

- Load more paper and continue the cycle.
- If there is paper on the table, but the error persists, clean the table empty sensor Q11. If the problem persists after that, contact service.

Continued on next page...

FE-108 - Paper table overload

In order to stop paper table movement in case it is overloaded paper stack height sensor Q4 measures the amount of paper on the table when feed cycle starts. If the media used is longer than 700 mm (27.6") the permitted paper stack height is limited to 100 mm (3.9"). If this height is exceeded the machine displays error code FE-108.

Actions:

- Check that the paper loaded in the feeder matches the parameters (size and thickness) set in the UI.
- Remove some of the paper stack from the feeder table.
- If the is paper stack is below the lower stack height marker on the paper wall, but the error persists, clean the paper stack height sensor Q4. If the problem persists after that, contact service.

FE-109 - Too much paper

In order to stop paper table movement in case it is overloaded paper stack height sensor Q4 measures the amount of paper on the table when feed cycle starts. If the media used is shorter than 700 mm (27.6") the permitted paper stack height is limited to 200 mm (7.9"). If this height is exceeded the machine displays error code FE-109.

Actions:

- Remove some of the paper stack from the feeder table.
- If the is paper stack is below the higher stack height marker on the paper wall, but the error persists, clean the paper stack height sensor Q4. If the problem persists after that, contact service.

FE-112 - Double Sheet Detector (DSD) blocked

When starting the feed cycle each sensor is automatically checked for obstructions. Error code FE-112 is shown if the ultrasonic double sheet detector (US DSD) Q10 is blocked during cycle start.

Actions:

- Remove any jammed sheets from the paper path. If the sheet is damaged, discard it.
- Check the paper path for any obstructions or debris.
- If there is nothing covering the sensor, but the problem persists, clean sensor Q10 using the sensor cleaning brush. If the problem persists after that, contact service.

Continued on next page...

FO-301 - Jam between units B

Jam between units B occurs when it takes too long for a paper to cover the distance between sensor Q7 and sensor Q40. This means that the paper got stuck between the rollers.

Actions:

- See Section 4 - Jam in the Folder
 - Check for misfeed sheets / debris under the sensor box (where Q7 is located)
 - Lower FAN1 power
 - Ensure that there are no obstructions in the paper path
-

FO-302 - Jam between units C

Jam between units C occurs when Q40 sensor is activated for too long. This means that the paper got stuck between the rollers.

Actions:

- See Section 4 - Jam in the Folder
 - Check input guides
 - Check that creaser tools are in open position (see setting crease pressure)
 - Ensure that there are no obstructions in the paper path
-

FO-305 - Fold 1 Sensor not covered in time

This error occurs when it takes too long for a paper to cover the distance between sensor Q40 and sensor Q45.

Actions:

- See Section 4 - Jam in the Folder
 - Check that creaser tools are in open position (see setting crease pressure)
 - Ensure that there are no obstructions in the paper path
-

FO-306 - Fold 1 Sensor not uncovered in time

JAM 306 - Fold 1 Sensor not uncovered in time

This error occurs when the Q45 sensor is not uncovered in time.

Actions:

- See Section 4 - Jam in the Folder
 - Check paper path in delivery module
 - Ensure that there are no obstructions in the paper path
-

FO-309 - Folder 1 position error

JAM 309 - Folder 1 position error

This error occurs when the Q41 Blade drive 1 home sensor is not actuated in time during run.

Actions:

- Remove misfed sheet(s)
- Ensure that there are no obstructions in the paper path

Continued on next page...

FO-310 - Folder 2 position error

This error occurs when the Q42 Blade drive 2 home sensor is not actuated in time during run.

Actions:

- Remove misfed sheet(s)
- Ensure that there are no obstructions in the paper path

FO-311 - Folder position error

This error occurs when the Q47 folder knife drive home sensor not actuated in time during run.

Actions:

- Remove any misfed sheet(s)
- Ensure that there are no obstructions in the paper path

FO-312 - Exit sensor not covered in time

This error occurs when the Q52 sensor is not actuated in time during run.

Actions:

- Remove any misfed sheet(s)
- Ensure that there are no obstructions in paper path

FO-313 - Exit sensor not uncovered in time

This error occurs when the Q52 sensor is not uncovered in time during run.

Actions:

- Remove any misfed sheet(s)
- Ensure that there are no obstructions in paper path

FO-314 - Edge Sensor not covered in time

This error occurs when the Q45 sensor is not covered in time during run.

Actions:

- Remove any misfed sheet(s)
- Check that creaser tools are in open position (see setting crease pressure)
- Ensure that there are no obstructions in paper path

FO-315 - Edge Sensor not uncovered in time

This error occurs when the Q45 sensor is not uncovered in time during run.

Actions:

- Remove any misfed sheet(s)
- Check that papers in stacker do not block exiting papers
- Ensure that there are no obstructions in paper path

Accuracy Checks

Alignment Calibration Check

To check that the machine has not lost its factory set alignment calibration during shipping and/or handling carry out the following procedure:

1. With the machine powered off open the top cover.
2. Take a stiff sheet of paper [A] and slide it against the registration wall [B].
 **NOTE:** Paper [A] must adhere to Paper Guidelines section of this manual.
3. Slide the sheet forwards until it comes in contact with creaser rollers. Check if both corners [C] of the sheet enter the rollers at the same time. Make sure that during this check the sheet remains parallel to the registration wall.

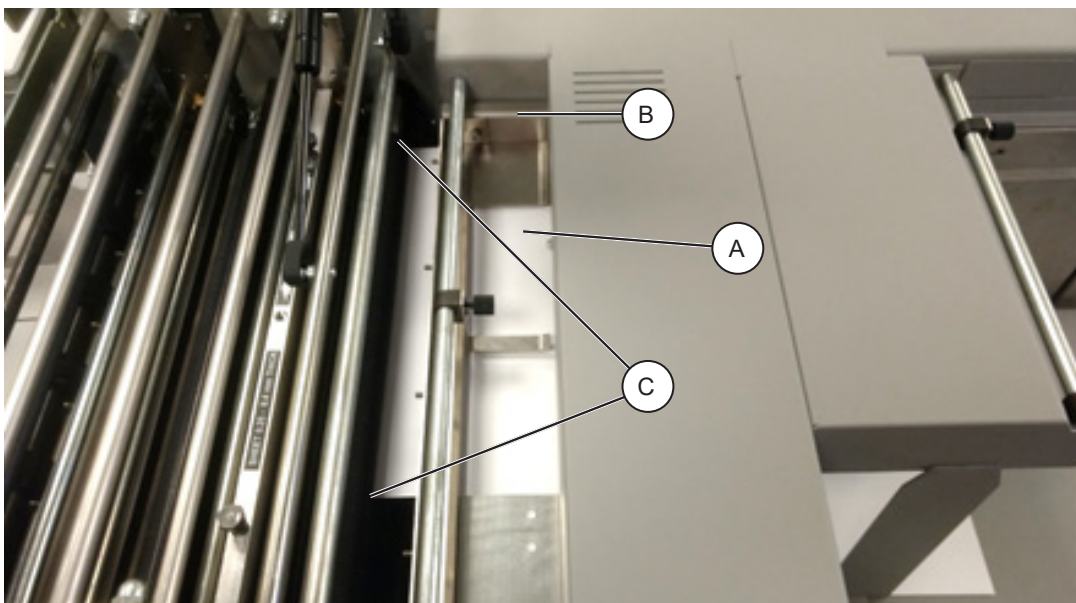

4. If sheet [A] does not enter the rollers at the same time contact a certified service technician.
5. Close the top cover and power on the machine.
6. Run a proof sheet with a single crease and inspect the output.



Continued on next page...

7. If the crease is skewed, adjustment is necessary.



NOTE:

Wrong crease positions are marked in red, correct crease position is marked in green.

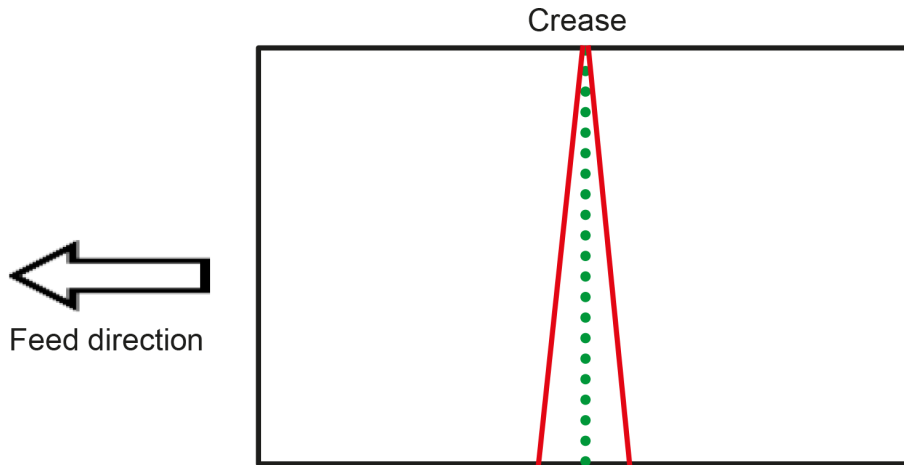

8. To adjust crease skew, loosen the crease adjustment knob by rotating it counterclockwise.

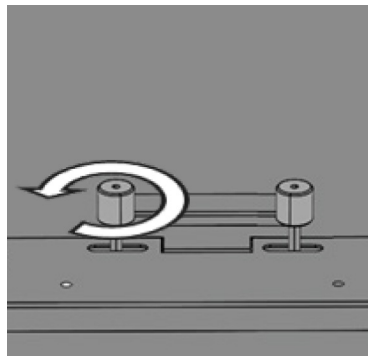

9. Move the knob slightly, either to the left or to the right depending on the direction of the crease skew.

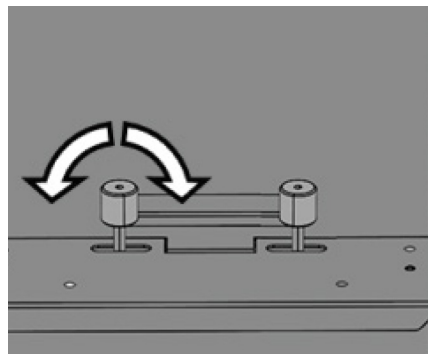

10. Rotate the knob clockwise to secure it.

11. Run another proof sheet to check if the crease is now perpendicular to sheet edge.
Repeat steps 6 to 10 if necessary.

Separation Pad Check

Rubber separation pads are used in the feeder to prevent several sheets from exiting the feeder table area at the same time. Separation pad position is set at the factory. If frequent misfeeds or double sheets occur the separation pad position may need to be adjusted by the following procedure:

3

1. Use a steel ruler or several stiff sheets of paper to check the gap between the separation pads [B] and the lowest point of the vacuum belt roller is even and around 1 mm (0.04"). If it is, the cause of misfeeds or double feeds is likely feeder parameters.
2. If not, use the included 2.5 mm hex key to loosen 2x bolts [A].
3. The separation pads [B] should now freely move up and down.
4. Use a steel ruler or several stiff sheets of paper to set the gap between the separation pads [B] and the vacuum belts to 1 mm (0.04").
5. Tighten the bolts [A].

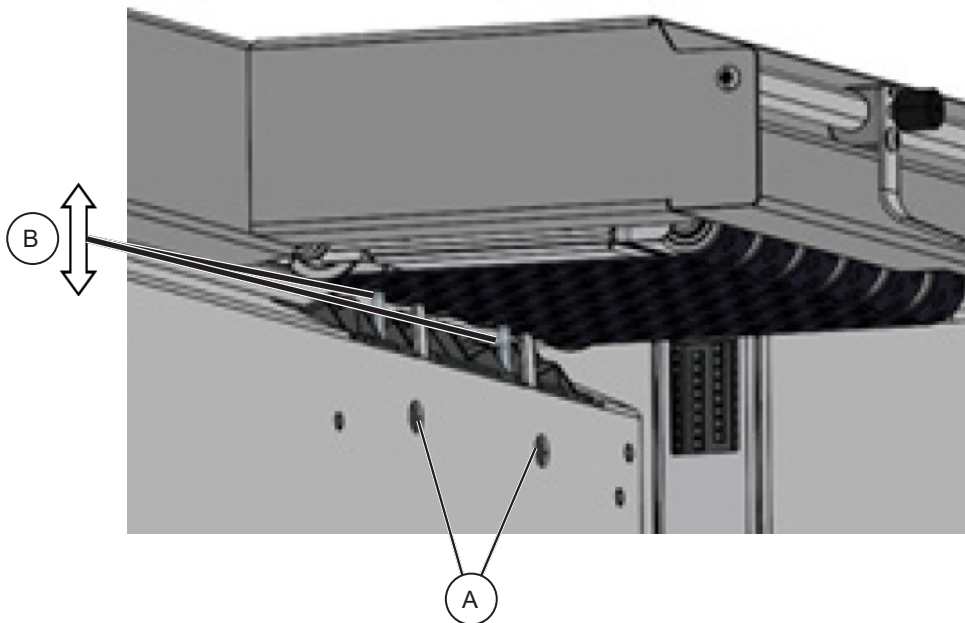

Creaser Calibration Check

To check that the machine has not lost its factory set crease calibration during shipping and/or handling carry out the following procedure:

1. Turn off Fold, run a proof sheet with a half fold pattern.



3

2. Measure the distance between the lead edge of the paper and the crease. The measurement should equal to the paper length divided by 2.

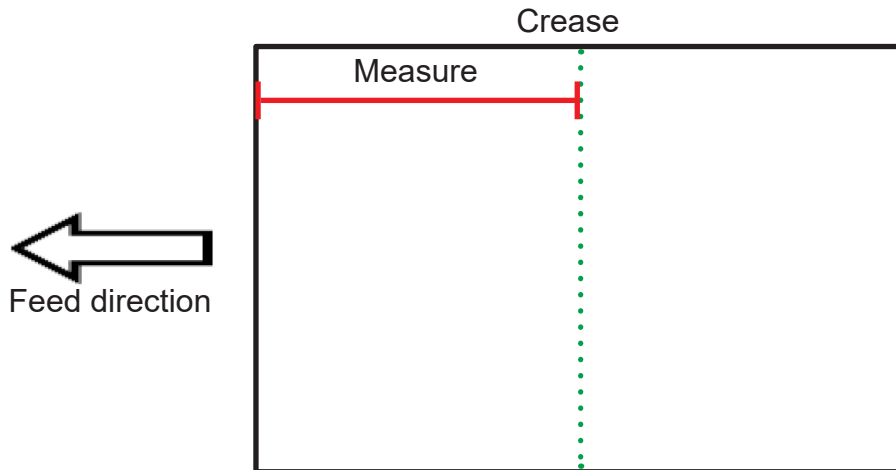

3. If the measurement is not within the machine tolerance (± 0.25 mm / ± 0.001 ") contact contact a certified service technician.

Fold Calibration Check

To check that the machine has not lost its factory set fold calibration during shipping and/or handling carry out the following procedure:

1. Turn off Crease, run a proof sheet with a half fold pattern.

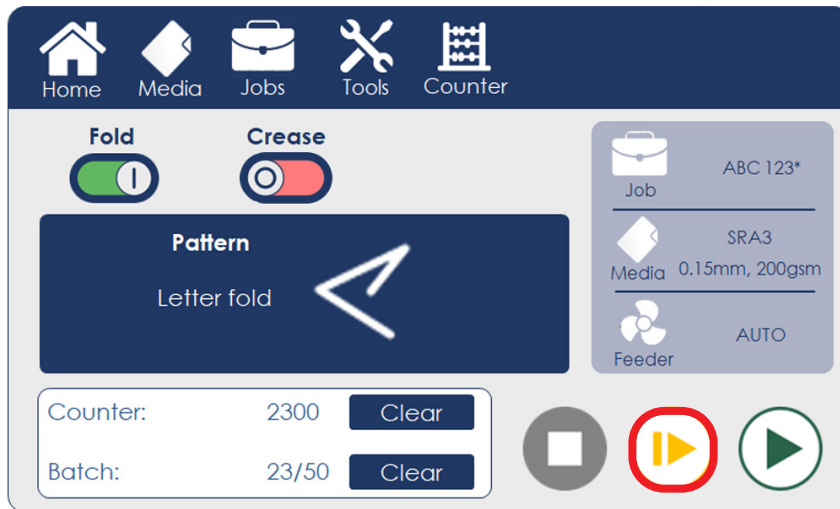

2. Measure the distance between the lead edge of the paper and the crease. The measurement should equal to the paper length divided by 2.

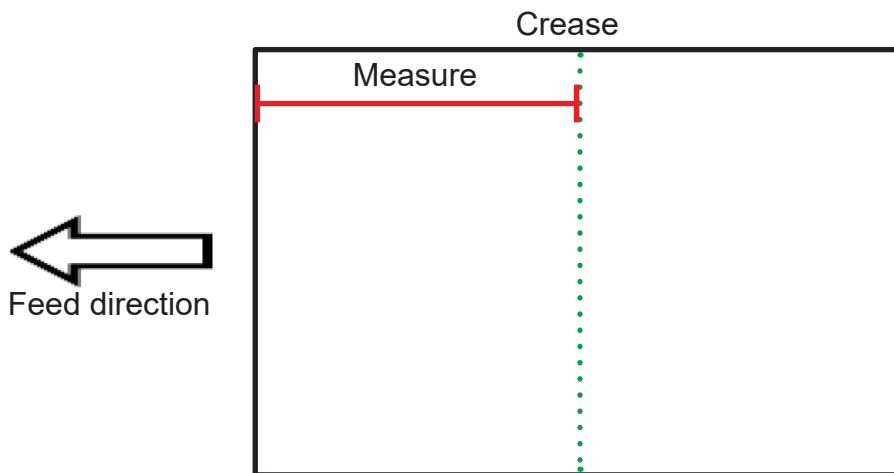

3. If the measurement is not within the machine tolerance (± 0.25 mm / ± 0.001 ") contact a certified service technician.

How to get support

CAUTION:

Never attempt any maintenance that is not specifically described in this documentation. Please contact your Dealer for authorized servicing.

If you encounter problems running this machine and you cannot solve them by following the advice given in the Troubleshooting section of this manual, please contact your authorized Formax Dealer for further support.

When contacting your Dealer please provide as much information as possible about the job you are attempting to run, and the problems you encounter.

3

- What machine do you have?
 - You can find the model name and serial number of your machine on the name-plate in the feeder shelf.
 - You can find the software version of your machine in the Tools menu.
- What job are you running?
 - Paper size, thickness and weight (gsm / lbs.)
 - Paper finish – plain / coated / silky / textured
 - Pre-set / custom job
 - Creasing / perforation
- What is the issue?
 - Feeding problems
 - Creasing problems
 - Fault codes displayed by the machine
 - What have you tried already to resolve the issue?

Page intentionally blank.

4. Remarks

Do's and Don'ts

- Always follow all warnings marked on, or supplied with, the equipment.
- Always exercise care in moving or relocating the equipment.

CAUTION:

Unplug the power cord from the wall outlet and the machine before you move or relocate the equipment.

- Do not remove covers or guards that are fastened with screws.
- Do not override or bypass electrical or mechanical interlock devices.
- Do not operate this equipment if you notice unusual noises or odors. Disconnect the power cord from the power source and call a certified service technician to correct the problem.

WARNING

This is a Class A product. In a domestic environment this product may cause radio interference in which case the user may be required to take adequate measures.

NOTE:

The domestic environment is an environment where the use of broadcast radio and television receivers may be expected within a distance of 10 m of the apparatus concerned.

- Do not switch off the power while the machine is running. Make sure the machine cycle has ended.
- Do not open covers while the machine is running.
- Do not move the machine while the machine is running.
- Do not make arbitrary changes to the machine.

Where to Put Your Machine

Machine Environment

- Always locate the equipment on a solid support surface with adequate strength for the weight of the machine.
- Always keep magnets and all devices with strong magnetic fields away from the machine.
- If the place of installation is air-conditioned or heated, do not place the machine where it will be:
 - Directly exposed to cool air from an air-conditioner
 - Subjected to sudden temperature changes
 - Directly exposed to heat from a heater

4

Power Connection

- **Always** connect the equipment to a properly grounded power source. If in doubt, have the power source checked by a qualified electrician.

 **WARNING**

Improper grounding of the equipment can result in electrical shock.

- **Never** connect the machine to a power source that lacks a ground connection terminal. A missing ground will cause damage to electronics and cause machine malfunctions.

Access to Machine

Place the machine near a power source, providing clearance as shown.

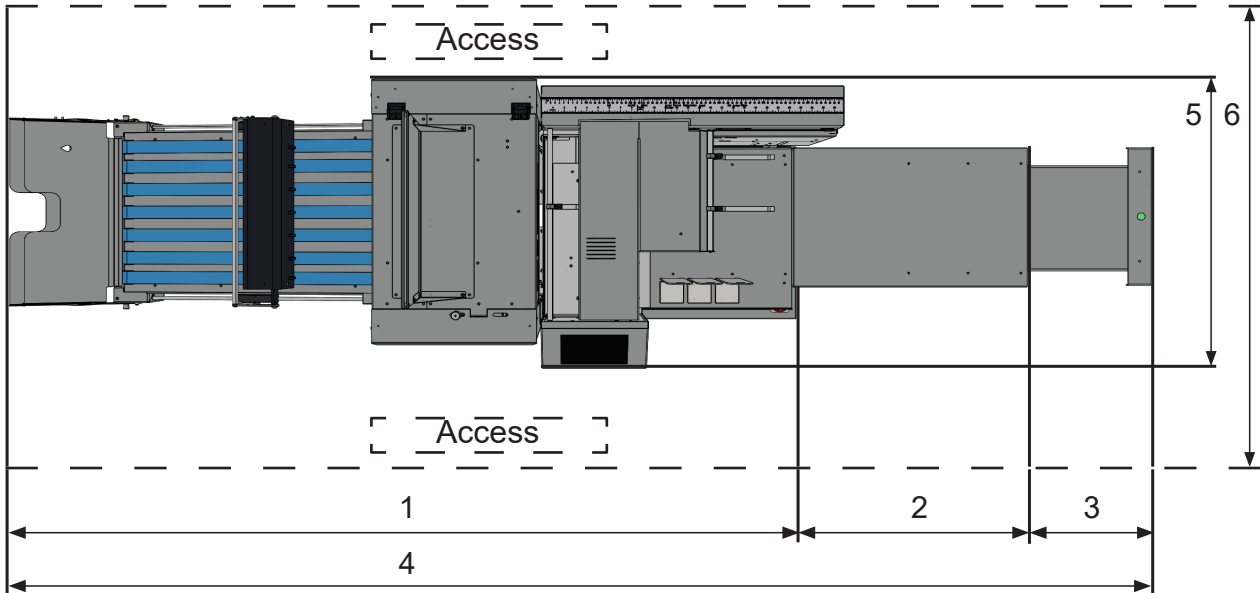

4

Product Dimensions			
Position	Description	mm	inches
1.	Length (no extension)	2130	83.9
2.	Table extension length	590	23.2
3.	Table extension maximum length	310	12.2
4.	Length (maximum) with table extension	2990	117.7
5.	Width	740	29.1
6.	Clearance for operation and service	1740	68.5

Note: the Atlas C350 is 54.9" high.

Recommended Weekly Operator Maintenance

⚠ CAUTION:

Never attempt any maintenance that is not specifically described in this documentation. Please contact your Dealer for authorized servicing.

Recommended Weekly Operator Maintenance

To maintain the accuracy and reliability of this machine it is recommended to carry out the following maintenance on a weekly basis:

1. Power off the machine using the main power switch. Remove any remaining paper from the feeder table.
2. Wipe down the feeder table and other paper path surfaces.
3. Check feeder separator pads for damage or wear.
4. Clean vacuum belts and paper feed rollers from any paper or toner dust using the supplied roller cleaning brush [A].
5. Remove the rotary tool carrier to clean its rollers.
6. Remove and clean the Quick Release Blade creasing blade.
7. Clean all sensors using the supplied sensor cleaning brush [B] (see next page).
 - Table empty sensor Q11 [C]
 - Separated paper (SP) sensor Q12 [D]
 - Top down paper sensor Q4 [E]
 - Input sensor Q20 [F]
 - Creaser home sensor(s) [G]
 - Clean the suction belts [H] with rubber reactivator alcohol.
 - Check the separator pads [I] for wear, tear and position (refer to 'Separation Pad check' in section 3 of this manual for how to measure the default position). Replace if worn (rounded edges/warped) or if broken.

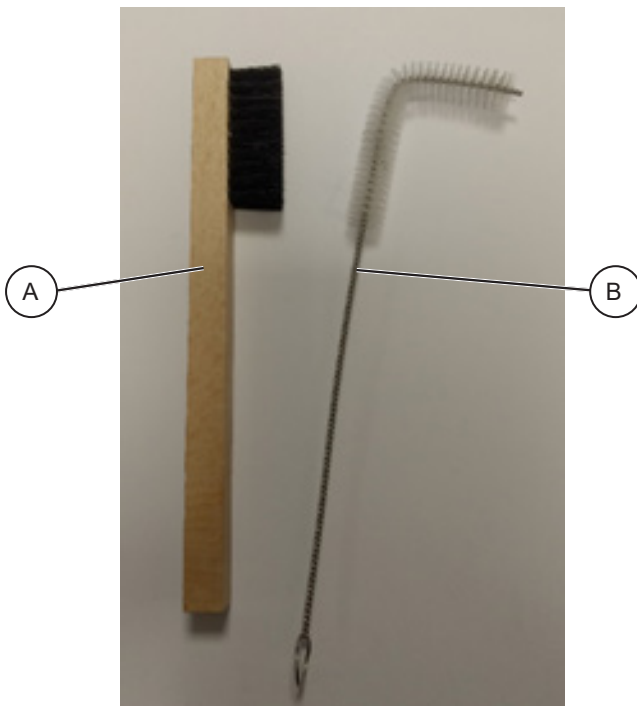

✎ NOTE:
For instructions on how to remove the creasing blade, see the "Replacing Quick Release Blade Sets" section within this manual.

Continued on next page...

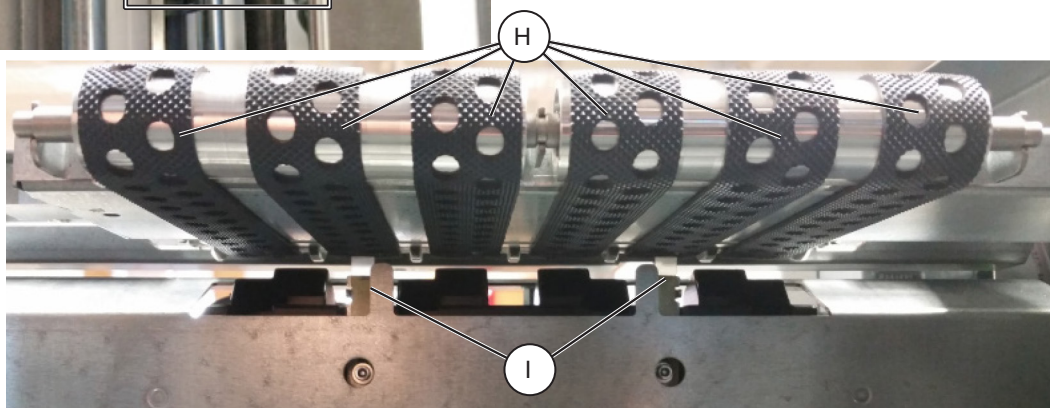
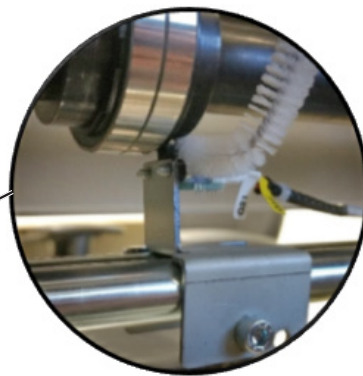
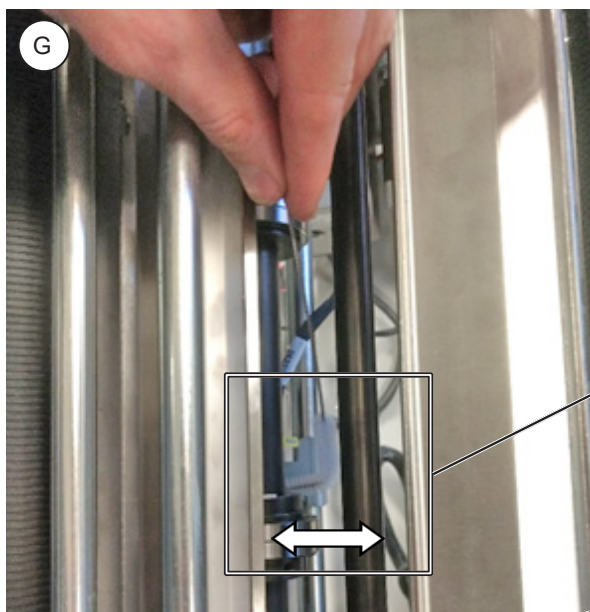
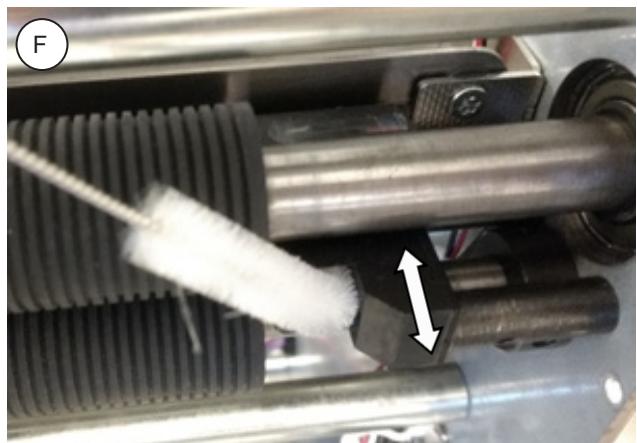
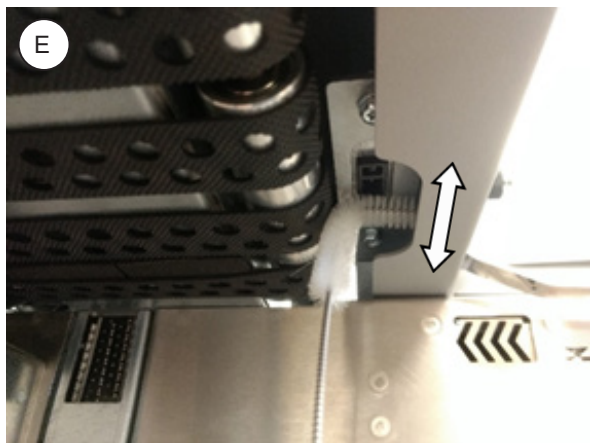
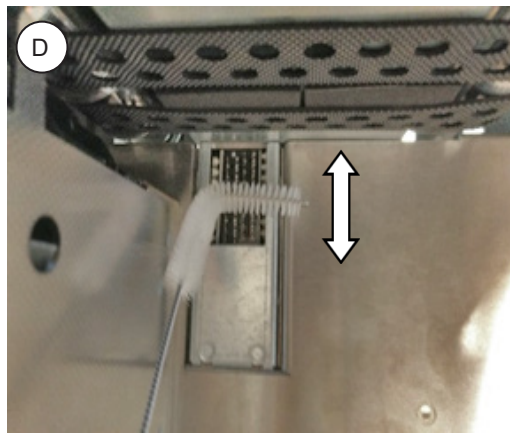
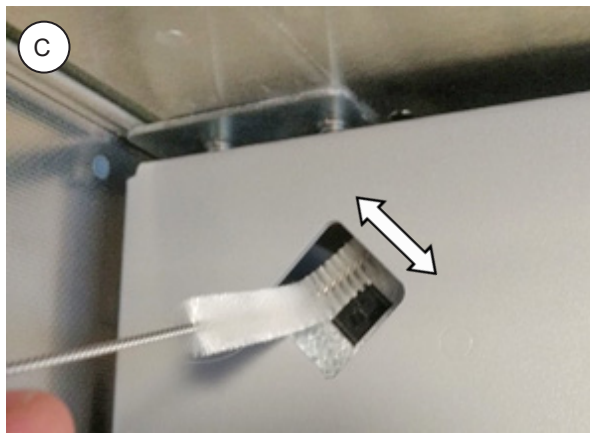

Limitations of the Atlas C350

- The intended average monthly sheet volume for the Atlas C350 is 450,000.
- Maximum creasing and folding hourly productivity of this machine is 6,000 sheets. This is measured using 200 gsm 8.5x11" paper short edge feed with a single crease and fold in the middle of the sheet.
- Maximum creasing-only hourly productivity of this machine is 8,500 sheets. This is measured using 200 gsm 8.5x11" paper short edge feed with a single crease in the middle of the sheet using the first (optional) creaser.
- Paper quality affects the output quality of this machine. If the sheets entering this machine are not uniform and square, the output will vary accordingly.
- The Shut Down Rate (SDR) of this machine is 1/2000 feeds.
- Feeder paper capacity is limited to:
 - 200 mm (7.9") for sheets up to 700 mm (27.6") in length
 - 100 mm (3.9") for sheets longer than 700 mm (27.6")

5. Specifications

Machine Specification

General

Power source	Voltage: 100-240 V ac (tolerance -10/+6%) Current: 8-4 A Frequency: 50/60 Hz
Power consumption	Standby: 55W Maximum: 750 W
Operating temperature	10-30 °C (50-86 °F)
Humidity	30-80 % RH
Sound emissions	80 dB

Physical characteristics

Product	Length	Width	Height	Weight
Atlas C350	1600mm (63")	730 (28.7")	1400mm (55.2")	313kg
Atlas C350 with table extension	2765mm (108.9")	730 (28.7")	1400 mm (55.2")	
Packaged	1200 mm (47.2")	800 mm (31.5")	1305 mm (51.4")	368kg

Continued on next page...

Paper handling

Feeder Module	
Max stack:	200 mm (100 mm for sheet lengths above 700 mm) 7.9" (3.9" for sheet lengths above 27.6")
Max paper size W x L:	385 x 700 mm (385 x 1300 mm with table extension) 15.2" x 27.6" (15.2" x 51" with table extension)
Min paper size W x L:	93 x 210 mm 3.7" x 8.3"
Max paper thickness:	0.4 mm (400 gsm) 0.0157"
Min paper thickness:	0.09 mm (80 gsm) 0.0035"
Max paper curl	±6 mm ±0.24"
Static crease module (Optional module)	
Minimum crease to crease distance	0.1mm 0.004"
Creasing resolution	0.1mm 0.004"
Stacker max paper size W x L	385 x 1040 mm 15.2" x 41"
Dynamic Crease module (Folder only)	
Minimum crease to crease distance (Fold on)	70mm 2.8"
Minimum Crease to crease distance (Fold off)	10mm 0.4"
Creasing resolution	0.1mm 0.004"
Stacker max paper size W x L	385 x 1040 mm 15.2" x 41"
Stacker capacity (creased sheets)	
Stacker capacity	120 mm 4.7"

Continued on next page...

Paper handling

Conditions:

- Paper size is assumed to be perfect
- Sheets are assumed to be perfectly 90°
- Tolerances are referring to deviations within one job

	A4 Letter	A3 Ledger
Crease position variation	± 0.20 mm ± 0.008"	± 0.20 mm ± 0.008"
Crease skew	± 0.25 mm ± 0.010"	± 0.40mm ± 0.016"
Fold position variation	± 0.25 mm ± 0.010"	± 0.25 mm ± 0.010"
Fold skew	± 0.25 mm ± 0.010"	± 0.25 mm ± 0.010"

5

Quality definitions

Measurements refer to any crease position.

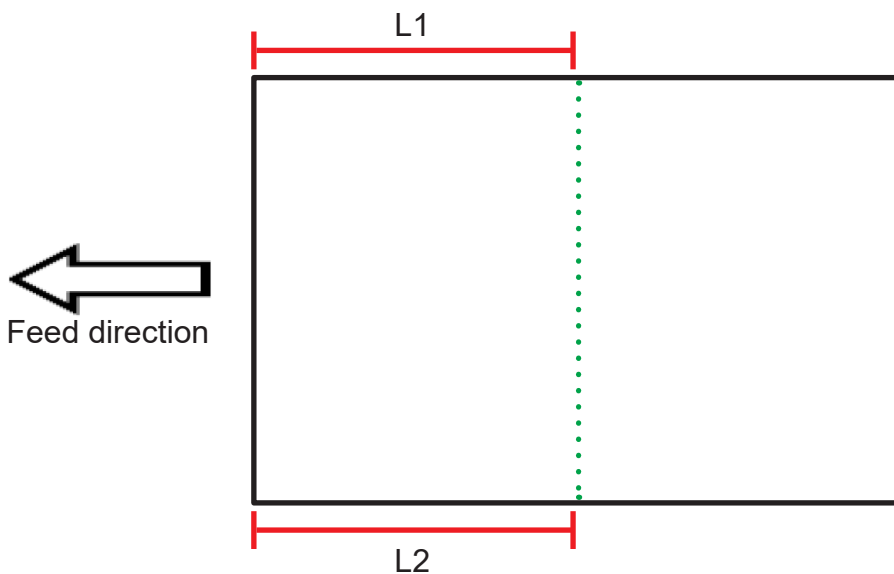

Crease position variation

Measurement $(L1+L2) / 2$ from sheet to sheet

Crease skew

Measurement $L1 - L2$